



colour monitor 14" - 16" - 20"

MTC 900.E

**MANUALE DI SERVIZIO
SERVICE MANUAL**



26"

22"

20"

16"

MTC 900-E

il « TOP » a colori per i Video-Games
the colour "TOP" for Videogames

H[®] **HANTAREX**[®] Electronic
Equipment
Manufacturer

la garanzia dell'esperienza

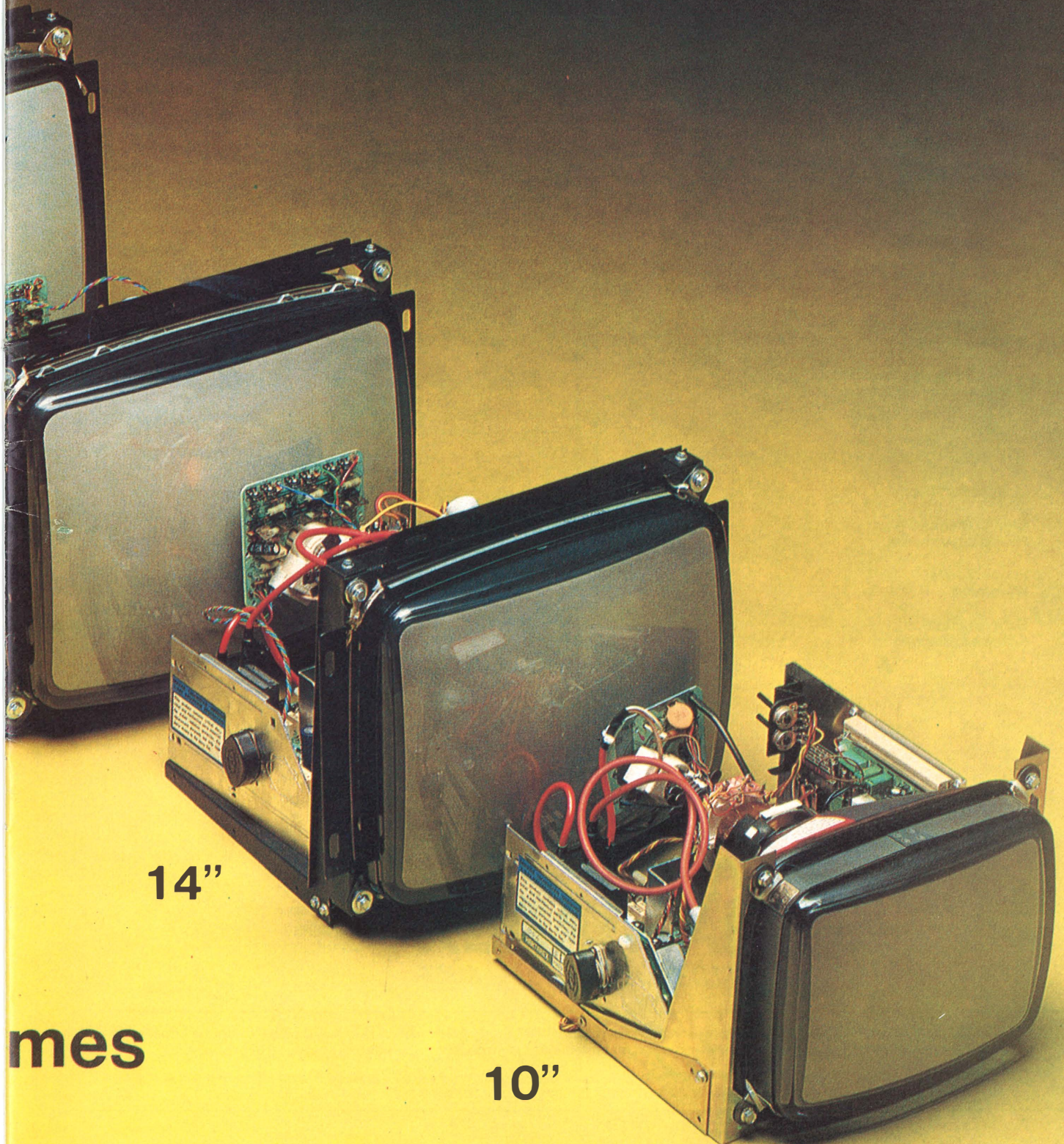

14"

10"

mes

INDICE

INDEX

MTC 900.E: vista frontale <i>MTC 900.E: front view</i>	pag. 3
MTC 900.E: posizione verticale e vista retro <i>MTC 900.E: vertical and rear view</i>	pag. 4
Avvertenze <i>Warning</i>	pag. 5
Protezione contro Raggi X <i>Protection against X-Ray radiation</i>	pag. 5
Istruzioni operative <i>Operating instructions and data</i>	pag. 5
Caratteristiche e Dati operativi <i>Performance and operating data</i>	pag. 6
Quadro caratteristiche elettriche <i>Electrical characteristics</i>	pag. 7
Procedura d'installazione <i>Setting-up procedure</i>	pag. 8
Trimmer di regolazione <i>Adjusting trimmers</i>	pag. 9
Diagramma connessioni <i>Connection diagram</i>	pag. 10
Caratteristiche meccaniche <i>Mechanical data</i>	pag. 11
Anelli di convergenza statica <i>Static convergence rings</i>	pag. 12
Optional	pag. 12
MTC 900.E 10" 90° – MTC 900.E 22"-26" 110°	pag. 13
Monitor Parts List	pag. 14
Circuiti Stampati <i>Printed circuit board</i>	pag. 16
Forme d'onda <i>Waveforms</i>	pag. 18
Schema Elettrico <i>Schematic diagram</i>	pag. 19



HANTAREX[®]

Electronic
Equipment
Manufacturer

QUALITY . RELIABILITY . SERVICE

HANTAREX s.p.a. si riserva il diritto di apportare, senza nessun preavviso, qualsiasi modifica tecnica di caratteristiche e materiali impiegati, qualora ciò si rendesse necessario per il miglioramento del prodotto o per nuove esigenze di produzione.

HANTAREX SPA reserves the right to introduce without warning alterations to specifications and to materials used whenever this is deemed necessary to improve the product or to meet the demands of changed production methods.

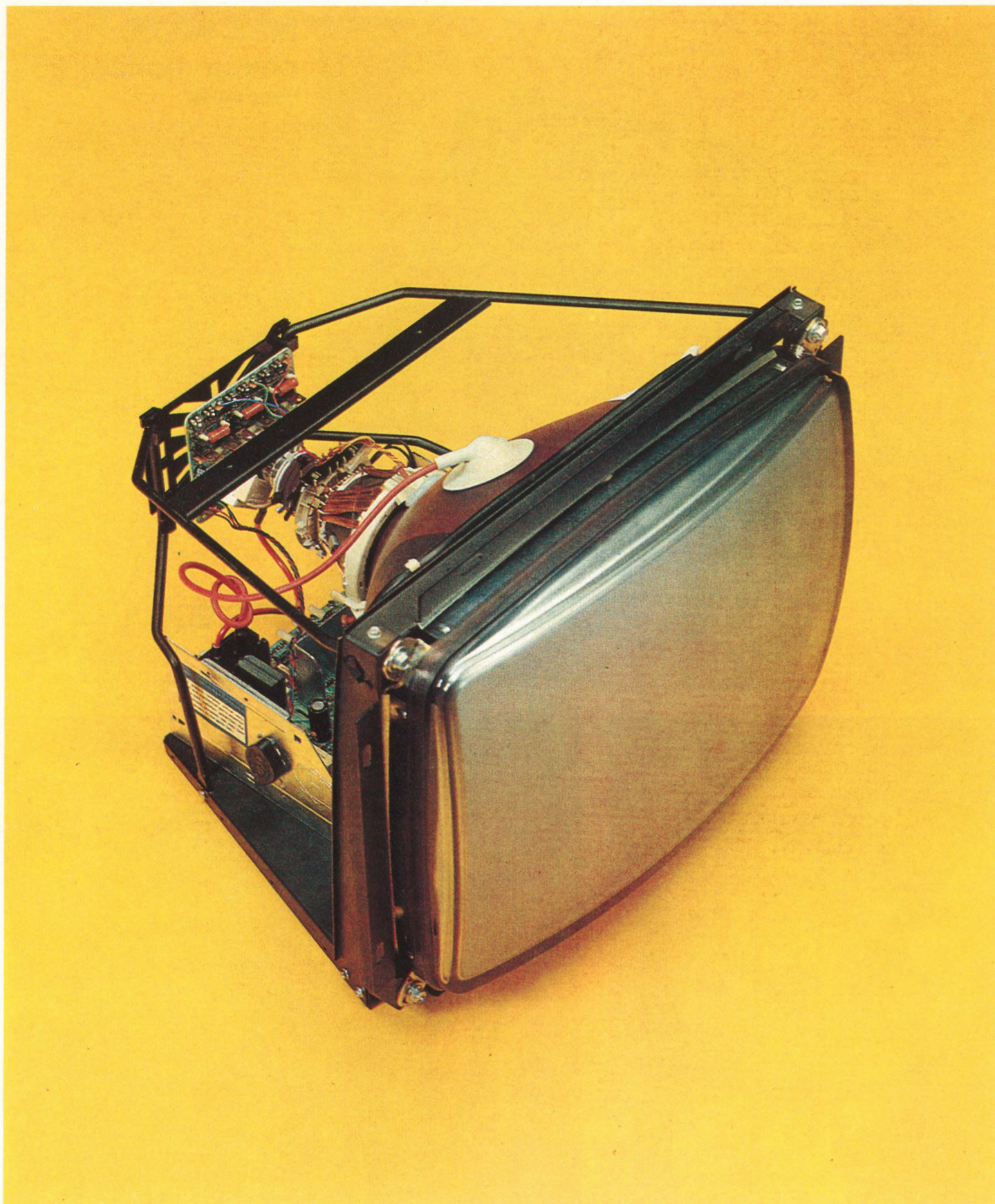

MTC 900-E

colour monitor 20"

MTC 900.E
colour monitor 20''
rear view



MTC 900.E
colour monitor 20''
vertical position

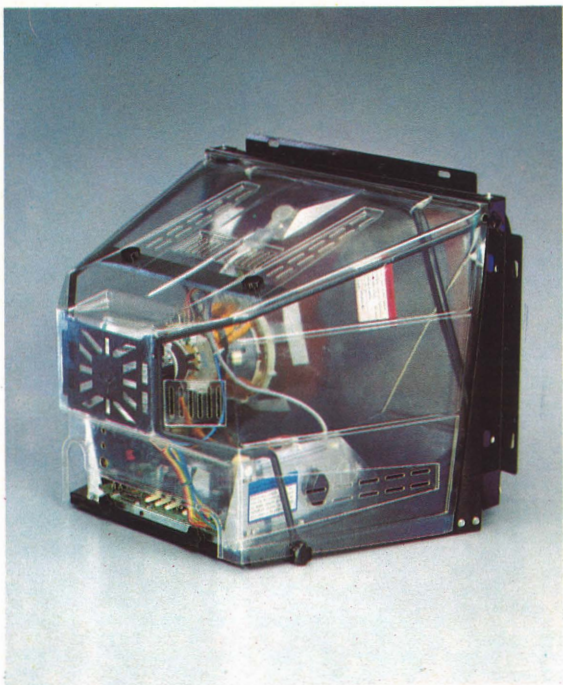

MTC 900 E.
colour monitor 20''
copertura protettiva di sicurezza
safe and accident-preventing protection

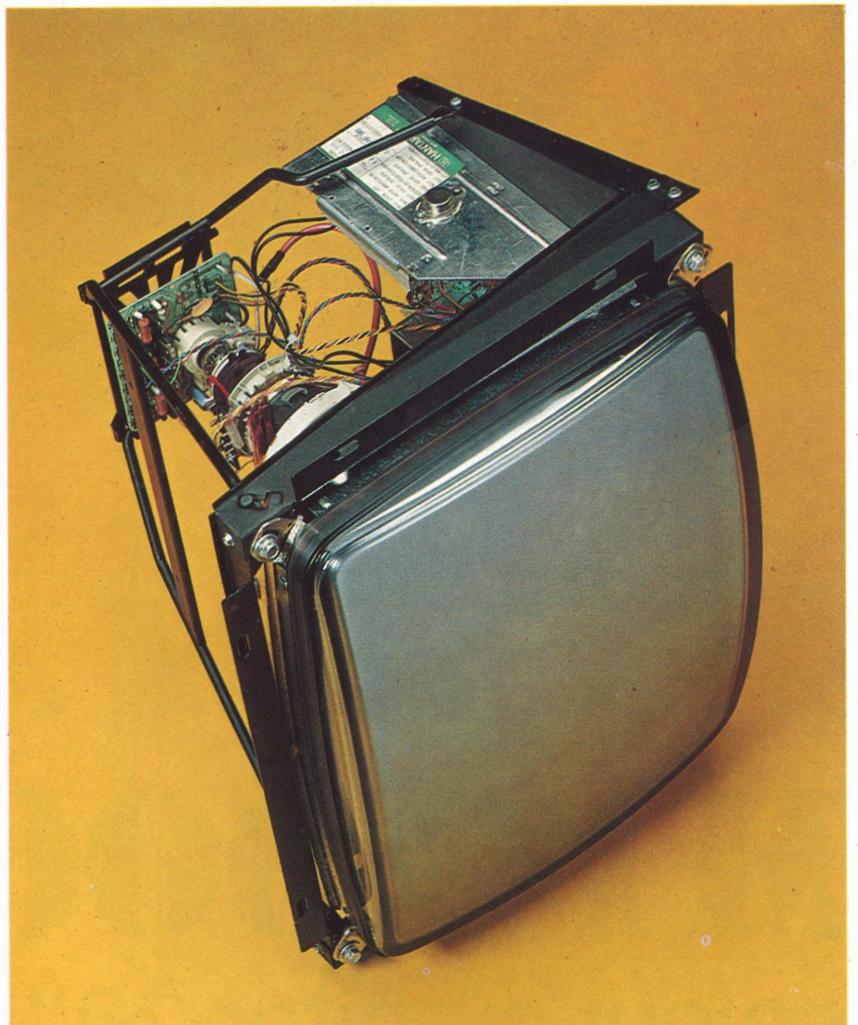

AVVERTENZE / WARNING

Il telaio e i dissipatori sono connessi a terra.

Perciò, per le misure di tensione, connettere il terminale negativo dello strumento di misura al telaio.

RAGGI X

Il telaio è stato progettato per emettere la radiazione minima di raggi X e uno speciale circuito di sicurezza garantisce che persino in caso di guasto la radiazione non superi mai 0,5 mR/h. Per questa ragione è necessario in ogni caso non alterare il circuito del CRT.

E.H.T.

Il monitor ha nel proprio interno sorgenti di alta tensione capaci di sprigionare energia pericolosa. Quindi per utilizzare l'apparecchiatura senza pericolo per l'operatore, attenersi alle precauzioni qui di seguito descritte.

C.R.T.

Il tubo a raggi catodici è un componente ad alto vuoto e le sue superfici sono soggette a forti pressioni esterne. È necessario perciò aver cura di non urtare o graffiare il tubo perché questo potrebbe causare implosione. Ne consegue che il personale responsabile per l'installazione deve usare guanti e indumenti protettivi contro le schegge.

SCARICA

Per prevenire la possibilità di scariche elettriche non esporre il monitor alla pioggia o all'umidità.

The chassis and the heat sinks are connected to ground. Hence, for the measurement of voltages, connect the negative terminal of the measuring instrument to the chassis.

X-RAYS

The chassis has been designed to give the minimum of x-ray radiation and a special safety circuit guarantees that even in the event of failure radiation will never exceed 0,5 mR/h. For this reason it is essential not to alter the C.R.T. circuit in any way.

E.H.T.

The monitor embodies sources of high voltage capable of delivering LETHAL amounts of energy. Hence to avoid harm to the operator, follow precautions set down for the servicing of E.H.T. equipment.

C.R.T.

The cathode-ray tube is a high vacuum component and its surfaces are subjected to strong exterior pressure. One therefore must take care not to knock or scratch the tube as this could cause implosion. It follows that the personnel responsible for its installation must use glasses and protective clothing against flying splinters.

SHOCK

To prevent the possibility of electrical discharges do not expose the monitor to rain or humidity.

PROTEZIONE CONTRO RAGGI X PROTECTION AGAINST X-RAY RADIATION

(PATENT N° 91830158.4)

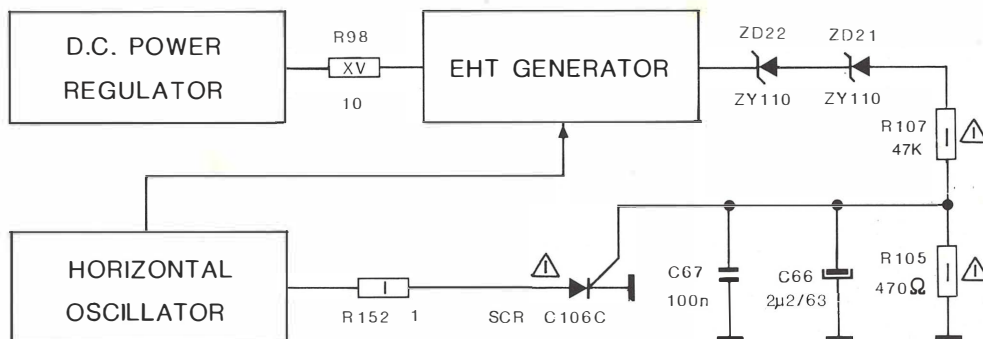

Il monitor MTC 900/E include un circuito di protezione per i raggi X. Una tensione di riferimento prelevata da un impulso del trasformatore EHT è inviata attraverso un partitore resistivo di tensione al GATE dell'SCR.

Quando la tensione EHT supera i 28,5 kV la tensione di riferimento al GATE dell'SCR deve aumentare sufficientemente in modo da innescarlo.

In tal modo l'SCR blocca l'oscillatore orizzontale e conseguentemente il generatore EHT.

Il circuito continua a bloccare l'oscillatore fino a che il guasto non è stato riparato e l'alimentazione resettata.

MTC 900/E monitor includes a « X ray radiation » protection circuit. A reference voltage taken from the secondary of the E.H.T. transformer is fed via a resistive voltage divider to the GATE of a S.C.R. When the EHT voltage becomes more than 28,5 kV, the reference voltage at the S.C.R. GATE will increase sufficiently to fire the SCR which stops the horizontal oscillator and therefore the generation of EHT. The circuit continues blocking the oscillation until the break down has been repaired and the supply reset.

ISTRUZIONI OPERATIVE OPERATING INSTRUCTIONS

- 1) Collegare il monitor con un trasformatore separatore con una tensione di uscita di secondario di 128 Vac per mezzo del connettore CB (vedi pag. 10)
- 2) Collegare la sorgente segnali al monitor tramite il connettore CA (vedi pag. 10)
- 3) **CONTROLLI D'INSTALLAZIONE**
Tutti i controlli sono preparati in fabbrica, ma possono essere aggiustati per adattarsi a un qualunque programma (vedi pag. 8 - PROCEDURA D'INSTALLAZIONE)
- 4) Per impulsi di syncro negato usare il ponticello SP5, filo arancione, in posizione FS7 sul circuito stampato PE (ingresso segnali: vedi pag. 9).
- 5) Per i segnali video negati usare i tre ponticelli R/G/B in posizione FS1-FS3-FS5 sul circuito stampato PE.

- 1) Apply a suitable power source to the monitor through an insulation transformer with an output voltage of 128 Vac by means of CB (see pag. 10)
- 2) Apply a suitable signal source to the monitor by means of connector CA (see pag. 10)
- 3) **SET UP CONTROLS**
All controls are preset at the factory, but may be adjusted to suit program material, please refer to page 8 (SETTING UP PROCEDURE)
- 4) For negative input SYNC. pulses use bridge SP5 with the orange wire in position FS7 on the P.C.B. (PE-interface board: refer to page 9).
- 5) For negative Video Signals use the three R/G/B bridges in position FS1-FS3-FS5 on the P.C.B. PE.

CARATTERISTICHE E DATI OPERATIVI

PERFORMANCE AND OPERATING DATA

1) ALIMENTAZIONE

	min.	typ.	max
TENSIONE	108 Vac	128 Vac	141 Vac
FREQUENZA	50 Hz		60 Hz

NOTA: Applicare la tensione di alimentazione attraverso un trasformatore di isolamento capace di erogare 1,5 ampere.

2) ALTA TENSIONE

per il modello 20"	22,5kV	—	25,5 kV
--------------------------	--------	---	---------

NOTA: Condizioni per sopra: 1 (beam) = 0 mA
tensione di alimentazione = 126 VDC

3) SEGNALI DI INGRESSO E RIFERIMENTI DI TERMINALI PER CONNETTORE CA

TERM. N°	DESCRIZIONE	IMPEDENZA	VARIAZIONE SEGNALI
1	ingresso blu	1k nom.	0 to 5.5V
2	ingresso verde	1k nom.	0 to 5.5V
3	ingresso rosso	1k nom.	0 to 5.5V
4	massa	—	—
5	sincro verticale	10k nom.	1,5V to 4V
6	sincro orizzontale	10k nom.	1,5V to 4V

4) SERVIZIO CONTROLLI INSTALLAZIONE

SUL CIRCUITO INTERFACCIA:	RV 12	taratura tensione alimentazione (tarare a 126 Vdc)
	RV 10	controllo luminosità
	RV 1,2,3	contrasto
SUL CIRCUITO DEFLESSIONE:	RV 13	frequenza orizzontale
	RV 14	fase orizzontale
	RV 23	centraggio verticale
	RV 17	linearità verticale
	RV 15	frequenza verticale
	RV 16	ampiezza verticale
	B 4	bobina linearità
	B 5	bobina ampiezza
SUL TRASFORMATORE E.H.T.:	G2	regolazione luminosità
		regolazione fuoco
SUL CIRCUITO ZOCCOLO CINESCOPIO:	RV 4, 6, 8	controllo pilotaggio video - « guadagno »
	RV 5, 7, 9	controllo cut-off CRT - « livello del nero »

1 SUPPLY

	min	typ.	max
VOLTAGE	108 Vac	128 Vac	141 Vac
FREQUENCY	50 Hz		60 Hz

NOTE: apply supply voltage through an isolation transformer with 1.5A capability

2) HIGH VOLTAGE

for 20" models	22,5 kV	—	25,5 kV
----------------------	---------	---	---------

NOTE: conditions for above: 1 (beam) = 0 mA
DC supply voltage = 126 VDC

3) INPUT SIGNAL AND PIN ASSIGNMENTS FOR CONNECTOR CA

PIN N°	DESCRIPTION	IMPEDANCE	SIGNAL RANGE
1	blu input	1k nom.	0 to 5.5V
2	green input	1k nom.	0 to 5.5V
3	red input	1k nom.	0 to 5.5V
4	ground	—	—
5	vertical sync. pulse	10k nom.	1,5V to 4V
6	horizontal sync. pulse	10k nom.	1,5V to 4V

4) SERVICE SET-UP CONTROLS

ON THE INTERFACE BOARD:	RV 12	supply voltage adjustment - set to 126 Vdc
	RV 10	brightness control
	RV 1,2,3	contrast
ON THE DEFLECTION BOARD:	RV 13	horizontal frequency
	RV 14	horizontal phase
	RV 23	vertical shift
	RV 17	vertical linearity
	RV 15	vertical hold control
	RV 16	vertical amplitude
	B 4	linearity coil
	B 5	width coil
ON THE EHT TRANSFORMER:	G2	brightness preset control
		focus control
ON THE SOCKET BOARD:	RV 4, 6, 8	video drive control - « gain »
	RV 5, 7, 9	CRT cut-off controls - « black level »

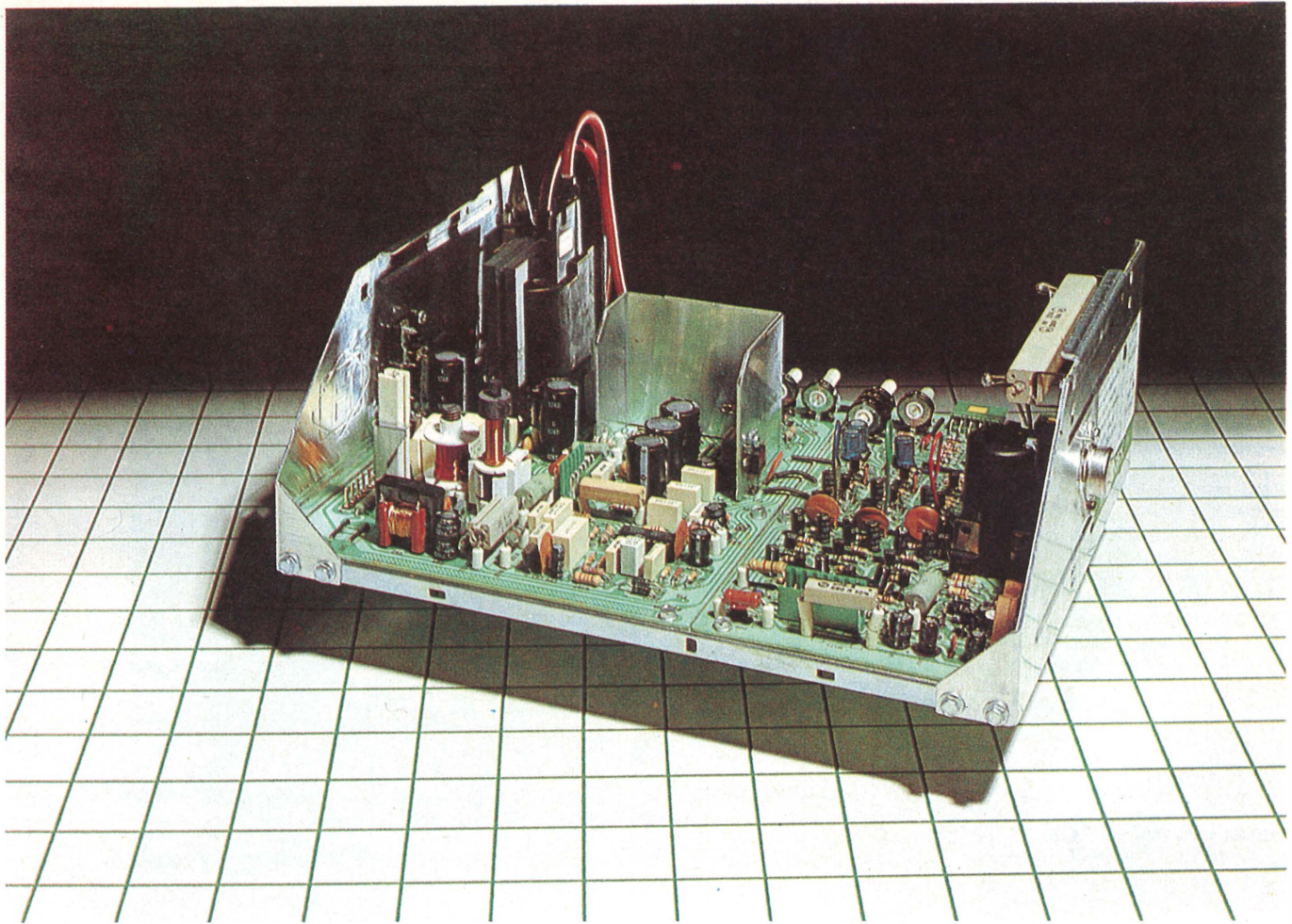

MTC 900.E 14"-16"-20": electrical characteristics

DESCRIPTION		MIN	TYP	MAX	UNITS
SUPPLY					
INPUT AC POWER	MONITOR INPUT WITH INSULATION TRANSFORMER	108	128	141	Vac
DEGAUSSING	AUTOMATIC		110 220		W Vac
INTERFACE RGB ANALOG SIGNAL TTL COMPATIBLE					
VIDEO SIGNAL INPUT	RGB SIGNAL	1	4	5,5	Vpp
SYNC. INPUT	TTL COMPATIBLE SEPARATE HORIZONTAL AND VERTICAL OR COMPOSITE (H + V) POSITIVE OR NEGATIVE INPUT	1.5	4	5,5	Vpp
BLANKING VIDEO	HORIZONTAL RETRACE/BLANKING TIME		11		μ s
	FREQUENCY RESPONSE (-3 dB)		12		MHz
	RISE TIME		50		ns
BEAM LIMITER CONTROLS	OVER SHOOT		0,5	3	%
	BEAM CURRENT		1		mA
	BRIGHTNESS AND CONTRAST		100		%
DEFLECTION					
GEOMETRY	HORIZONTAL LINEARITY		\pm 14		%
	VERTICAL LINEARITY		\pm 10		%
	PINCUSHION		\pm 3		%
	HORIZONTAL SCAN SIZE		- 4 + 10		%
	VERTICAL SCAN SIZE		\pm 15		%
E.H.T.					
E.H.T. X-RAY SAFETY	(126 Vdc / 0-beam current) E.H.T. VOLTAGE WHICH SHUT-OFF THE EMISSION MONITOR	22.5	24	25.5	kV
X-RAY			28.5	\leq 0.25	kV mR/h
C.R.T.					
90°	PRECISION IN LINE-HIGH FOCUS 14" VIDEOCOLOR A-37-420X 14" TOSHIBA 370-LN-322-TC03 16" VIDEOCOLOR A-42-420X 16" TOSHIBA 420-LNB-22 20" VIDEOCOLOR A-51-420X 20" ITT A-51-231X	14	20		INCHES

PROCEDURA D'INSTALLAZIONE SETTING-UP PROCEDURES

STRUMENTI NECESSARI

Multimetro digitale con impedenza ingresso di 10 MOhm.
Un oscilloscopio con una banda di 10 MHz e una sonda con attenuazione 10/1.
Un generatore di barre RGB tipo Hantarex K190G

Dopo che il monitor è stato acceso per circa 5 minuti, sistemare i controlli fino ad ottenere un'immagine accettabile e poi procedere all'allineamento del telaio secondo le seguenti istruzioni:

1) ALIMENTAZIONE SENZA SEGNALE

Tarare tramite RV12 la tensione di alimentazione e procedere agli aggiustamenti solo dopo la taratura, come segue:

- ruotare il controllo G2 in senso antiorario fino al minimo
- connettere un voltmetro digitale al punto SP20 e aggiustare RV12 fino ad ottenere una tensione di 126 Vdc (vedi pag. 10)

AVVERTENZA

Le tensioni maggiori o minori della nominale limitano le prestazioni del monitor.

2) LIVELLI INGRESSO RGB (segnale: barre colore)

Ruotare controllo luminosità RV10 fino al massimo (ruotare in senso orario). Misurare con oscillografo su R 27, R28, R31 dove è il minimo segnale e tararsi su questo per ottenere 0,5 Vpp ruotando RV1, RV2, RV3.

3) SEGNALE USCITA RGB (segnale: barre colore)

Tarare RV5, RV7, RV9 sul circuito dello zoccolo per ottenere sui catodi del verde, rosso e blu un livello del nero di 140 Vdc.

Tarare RV4, RV6, RV8 per ottenere negli stessi punti (catodi) un segnale di 50 Vpp.

Tarare RV10 (luminosità) per ottenere sui catodi un livello del nero di 160 Vdc.

Tarare G2 per ottenere un livello di cut-off sul cinescopio (cinescopio spento).

4) TARATURA DEL BIANCO (segnale: quadro bianco del Generatore K 190G)

Con RV10 ruotato in modo da avere visibile lo sfondo bianco, correggere il grigio attraverso RV5/RV7/RV9.

5) OSCILLATORE ORIZZONTALE (segnale: inserire il segnale Video e Syncro della Piastra Logica)

Cortocircuitare TP7 e TP8, poi aggiustare RV13 per ottenere una maggiore stabilità dell'immagine in senso orizzontale e poi togliere il corto circuito.

6) OSCILLATORE VERTICALE (segnale: inserire il segnale Video e Syncro della Piastra Logica)

Regolare RV15 fino ad ottenere un leggero scorrimento dell'immagine verso il basso, poi ruotare lentamente all'indietro fino a bloccare lo scorrimento.

7) GEOMETRIA ORIZZONTALE (segnale: reticolo)

Regolare la bobina di linearità orizzontale B4 per la massima ampiezza e poi tararla per la migliore linearità orizzontale. Aggiustare RV14 per un corretto centraggio dell'immagine. Infine ritarare l'ampiezza orizzontale con la bobina B5.

8) GEOMETRIA VERTICALE (segnale: reticolo)

Tarare RV16 fino a ridurre l'ampiezza dell'immagine di 3 cm rispetto all'altezza del cinescopio. Mediante RV23 centrare l'immagine in senso verticale e tarare di nuovo RV16 per la corretta ampiezza verticale ed RV17 per la migliore linearità.

9) FUOCO (segnale: reticolo)

Tarare il controllo di fuoco fino ad ottenere il miglior risultato visivo (vedi pag. 9).

AVVERTENZE

Il monitor è tarato per lavorare con un tempo di video attivo di circa 50 microsecondi.

Tuttavia per aumentare l'ampiezza del Video, delle Piastre con tempo di scrittura di 40 microsecondi, unire con saldatura, tramite un ponticello i punti SP24 SP 25 (vedi diagramma pag. 10).

INSTRUMENTATION REQUIRED

Digital multi-meter with input impedance of 10MΩ. An oscilloscope with a bandwidth of 10MHz and a 10/1 probe attenuator. An RGB color bar generator type HANTAREX K 190G.

After the monitor has been turned on for about 5 minutes, adjust the controls until an acceptable image has been obtained and then proceed to the alignment of the chassis according to the following instructions.

1) POWER SUPPLY WITHOUT SIGNAL

Variable resistor RV 12 adjusts the supply voltage and requires adjustment only following repair, in which case proceed as follows:

- turn the G2 control counterclockwise to the minimum.
- connect digital voltmeter to SP20 and adjust RV12 to obtain a voltage of 126 Vdc (see pag. 10).

WARNING

Voltages greater than or less than nominal impair the functioning of the monitor.

2) RGB INPUT LEVELS. (signal: colour bars)

Turn RV10, brightness control, to the maximum; in a clockwise direction checking the minimum signal with oscilloscope on R27, 28, 31, adjust trimmers RV1, 2, 3 to have 0,5 Vpp at the same points.

3) RGB VIDEO OUTPUT (signal: colour bars)

- Adjust RV5; RV7; RV9 on the socket-board to obtain at KG; KR; KB, a "black level" at 140 Vdc.
- Adjust RV4; RV6; RV8 to have, at the same points, a "gain" of 50 Vpp.
- Adjust RV 10 (brightness) to have, at the same points, a "black level" at 160 Vdc.
- Adjust G2 to obtain cut-off on the CRT.

4) WHITE BALANCE (signal: white raster from Generator K 190G)

With RV10 turned to make a white background visible correct the grey by means of RV5; RV7; RV9.

5) HORIZONTAL OSCILLATOR (signal: connect the Video Sync. signal to the Logic Board)

Short circuit TP7 and TP8 then adjust RV 13 to obtain the most stable image in the horizontal sense and then remove the short circuit.

6) VERTICAL OSCILLATOR (signal: connect the Video and Sync. Signal to the Logic Board)

Adjust RV 15 so as to obtain a slight roll-over of the image in a downward direction. Then turn back slowly to stop this roll-over.

7) HORIZONTAL GEOMETRY (signal: crosshatch)

Set the horizontal linearity coil B4 for maximum amplitude and then adjust for the best horizontal linearity. Adjust RV14 for correct horizontal centering. Finally re-adjust horizontal amplitude by means of B5 width coil.

8) VERTICAL GEOMETRY (signal: crosshatch)

Adjust RV 16 so as to reduce the image by 3 cm with respect to the height of the CRT. By means of RV23 centre the graticule vertically, and adjust RV16 again for the correct vertical amplitude and RV17 for the best linearity.

9) FOCUS (signal: crosshatch)

Adjust focus control to obtain the best visual result (see pag. 9).

WARNING

The monitor is pre-set to work with a video active time of about 50μs.

However, to increase the horizontal scan amplitude on Boards with a 40 microsecond writing time, connect a shorting bridge between SP24 and SP25 (see Diagram on page 10).

ADJUSTING TRIMMERS

- RV5 - B cutaff
- RV4 - B gain
- RV7 - G cut-off
- RV6 - G gain
- RV9 - R cut-off
- RV8 - R gain

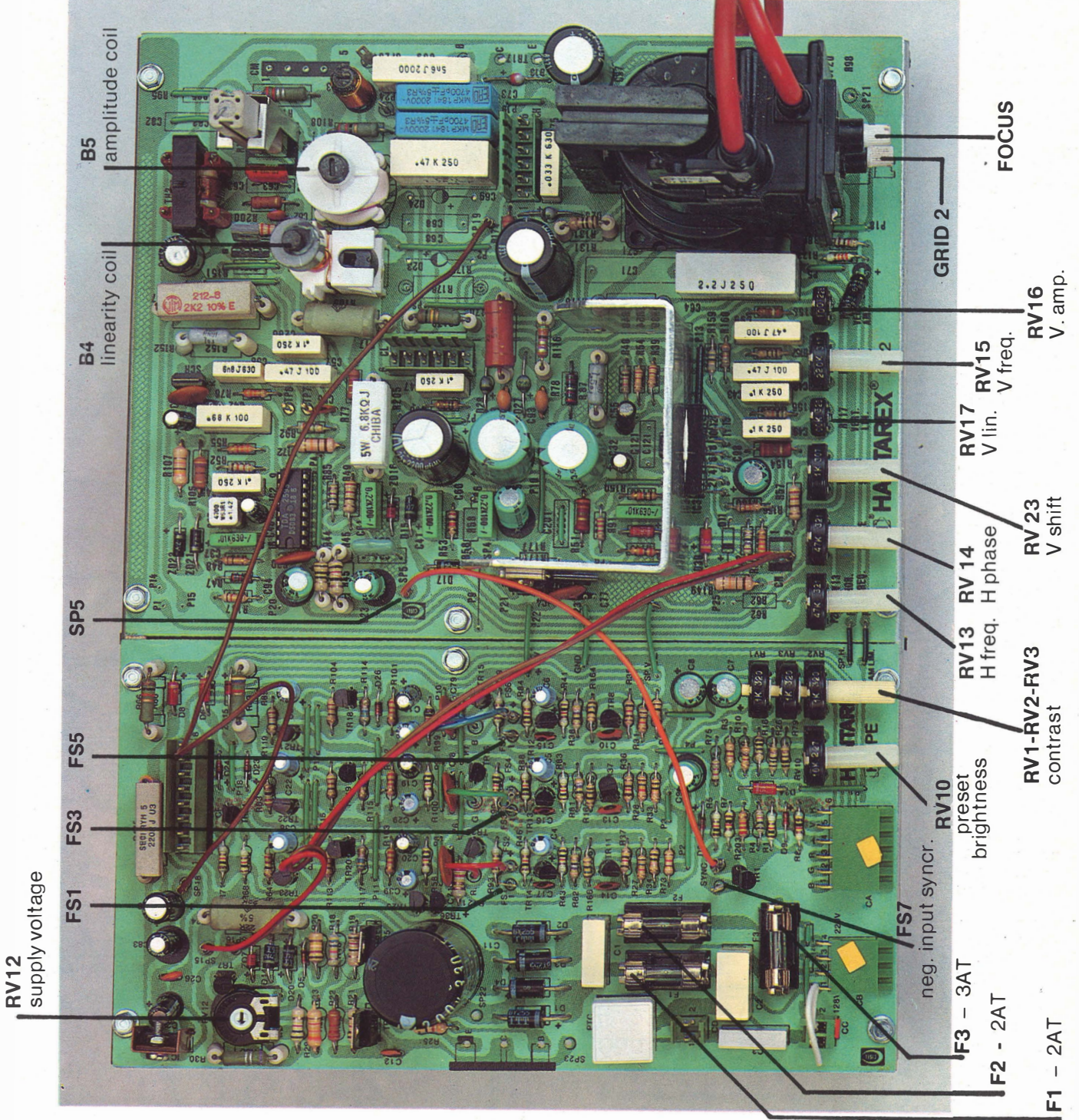
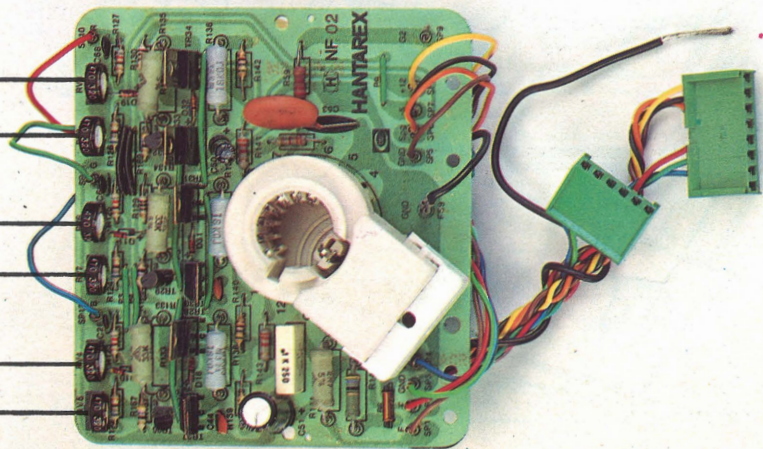

- RV12 - supply voltage
- FS1
- FS3
- FS5
- SP5
- B4 - linearity coil
- B5 - amplitude coil
- FOCUS
- GRID 2
- RV16 - V. amp.
- RV15 - V freq.
- RV17 - V lin.
- RV14 - H phase
- RV13 - H freq.
- RV23 - V shift
- RV1-RV2-RV3 - contrast
- RV10 - preset brightness
- FS7 - neg. input syncr.
- RV3 - 3AT
- RV2 - 2AT
- RV1 - 2AT

CONNECTION DIAGRAM

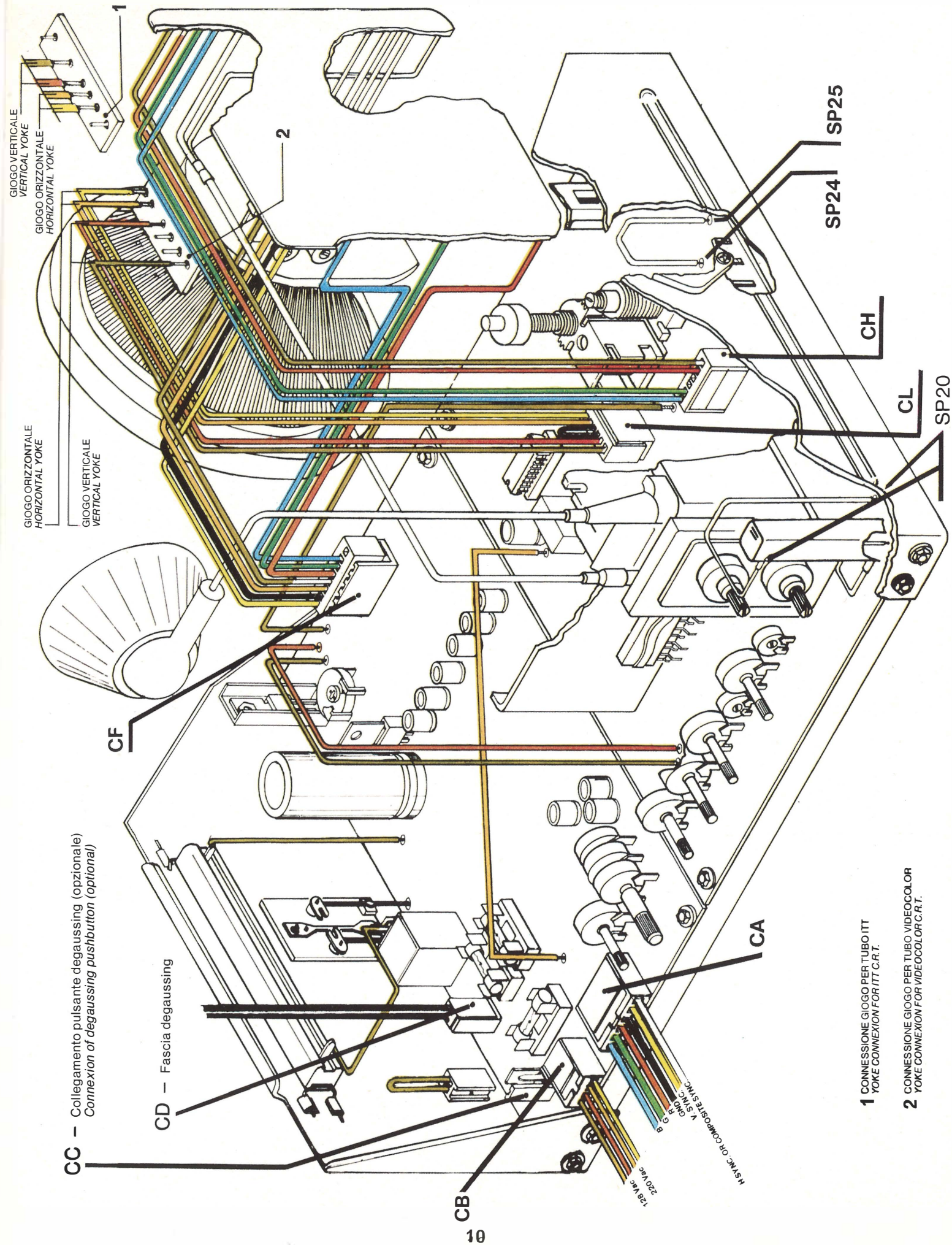

MECHANICAL DATA

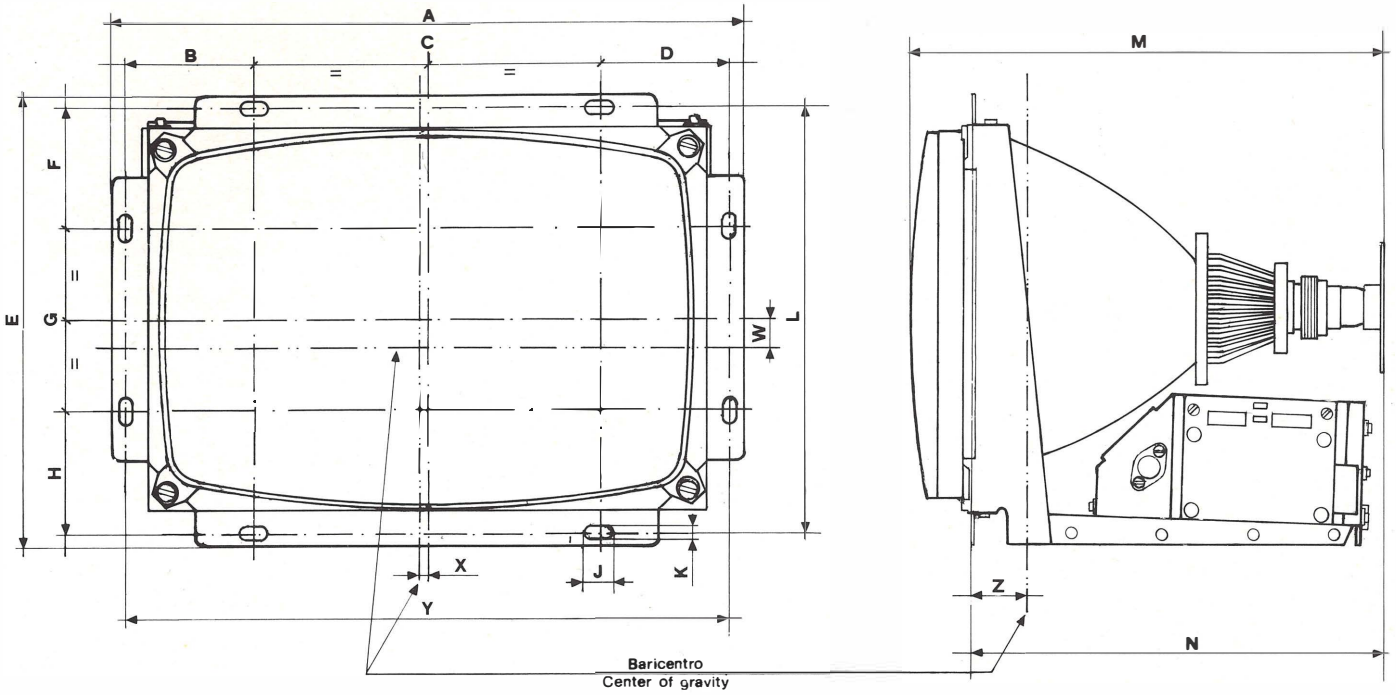

DIM.	A	B	C	D	E	F	G	H	J	K	L	M	N	W	X	Y	Z
14" mm	372	78	198	78	300	78	144	78	20	8	284	331	271	23	6	356	60
16" mm	424	78	250	78	347	78	175	78	20	8	331	363	310	32	6	408	47
14" IN.	14.646	3.071	7.795	3.071	11.811	3.071	5.669	3.071	0.787	0.315	11.181	13.031	10.669	0.905	0.236	14.016	2.362
16" IN.	16.693	3.071	9.842	3.071	13.661	3.071	6.89	3.071	0.787	0.315	13.031	14.291	12.205	1.26	0.236	16.063	1.85

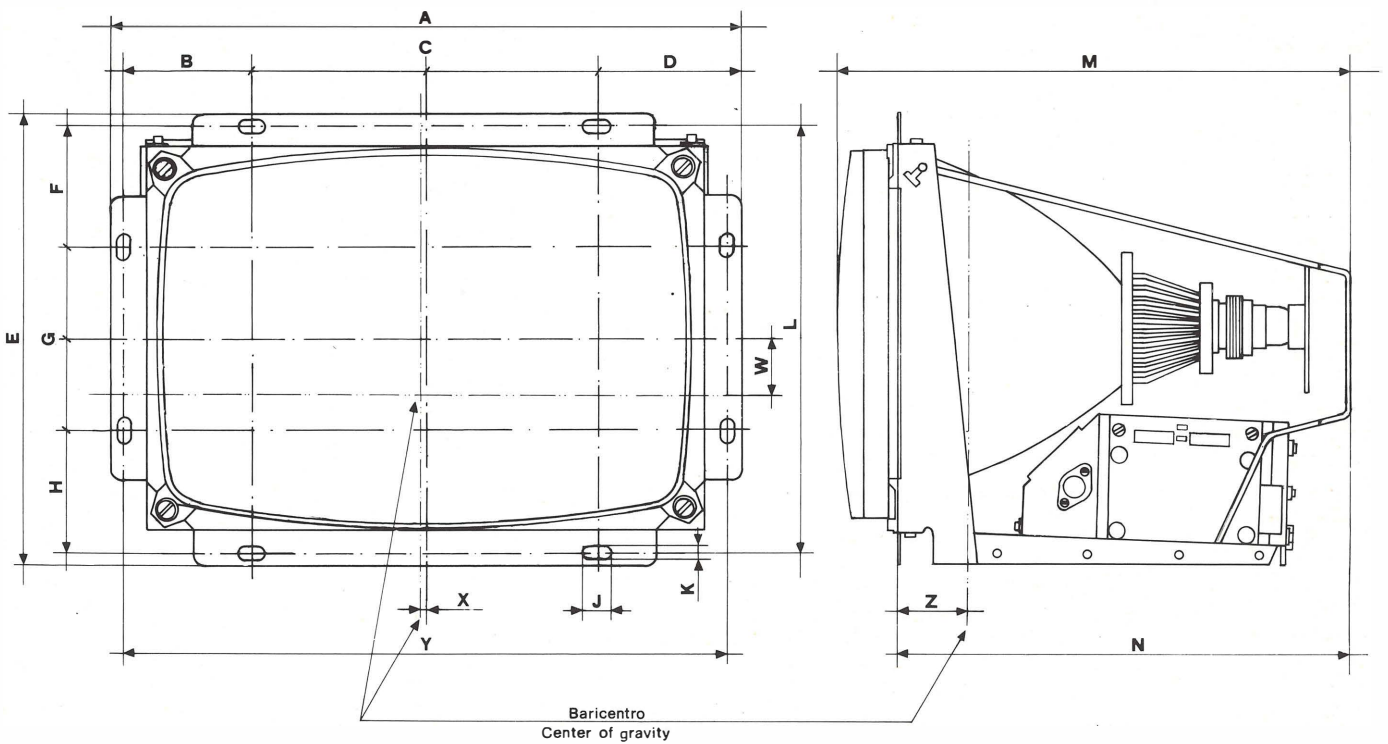

DIM.	A	B	C	D	E	F	G	H	J	K	L	M	N	W	X	Y	Z
20" mm	512	108	280	108	412	98	200	98	20	8	396	442	387	34	3	496	43
20" IN.	20.157	4.252	11.024	4.252	16.22	3.858	7.874	3.858	0.787	0.315	15.59	17.402	15.236	1.339	1.181	19.527	1.693

ANELLI DI CONVERGENZA STATICA

STATIC CONVERGENCE RINGS

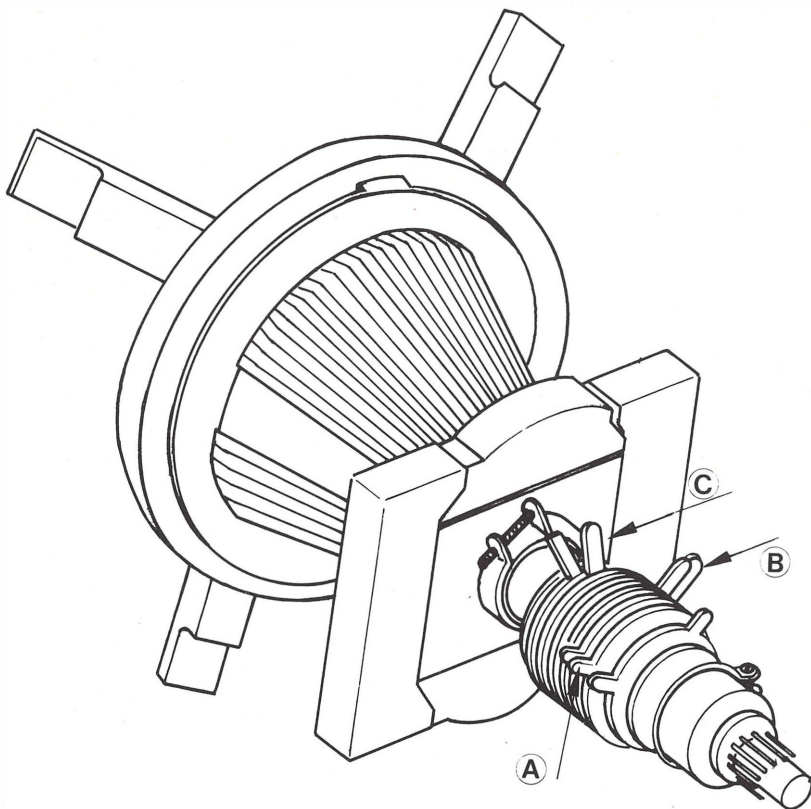

Il tipo di cinescopio usato è un autoconvergente. Tutte le tarature (purezza e convergenza) sono state fatte dal fornitore del cinescopio stesso.

In caso siano necessarie ritature di purezza o convergenza si deve operare come segue, usando un generatore di segnali con crosshatch.

Separare gli anelli dalla resina di fissaggio avendo cura di non ruotarli.

Le operazioni sugli anelli devono essere fatte come da sequenza

1) Per cinescopi ITT e VIDEOCOLOR:

A) questi anelli tarano la convergenza fra il rosso e il blu ai bordi

B) questi anelli tarano la convergenza fra il rosso e il blu al centro

C) questi anelli tarano il punto di purezza usando un generatore con un campo rosso

2) Per cinescopi TOSHIBA:

A) questi anelli tarano il punto di purezza usando un generatore con campo rosso.

B) questi anelli tarano la statica del verde.

C) questi anelli tarano la convergenza fra il rosso e il blu al centro.

Prima di operare assicurarsi che il monitor sia libero da campi magnetici residui.

Tutte le parti del telaio e del cabinet potrebbero magnetizzarsi, sarà quindi necessario smagnetizzarle manualmente.

The kind of picture tube used, is selfconvergence type. All adjustments (purity and convergency) are directly made by the tube manufacturer.

In case convergence or purity readjustments are required, you can operate as follows using a crosshatch pattern generator: Release the rings from the fixing resin taking care not to turn them.

The rings operate with the following sequency.

1) For ITT and VIDEOCOLOR C.R.T.:

A) These rings adjust convergency between red and blue to edge.

B) These rings adjust convergency between red and blue to centre.

C) These rings adjust points out of purity using a generator with a red field.

2) For TOSHIBA C.R.T.:

A) these rings adjust points out of purity using a generator with a red field.

B) these rings adjust green static.

C) these rings adjust convergency between red and blue to edge.

Before operating, please take care that the monitor is free from residual magnetic fields.

Should any part of the chassis or cabinet become magnetized, it will be necessary to degauss the affected area by means of a manual degaussing coil.

OPTIONAL

SUPPORT FOR CHASSIS ASSEMBLY

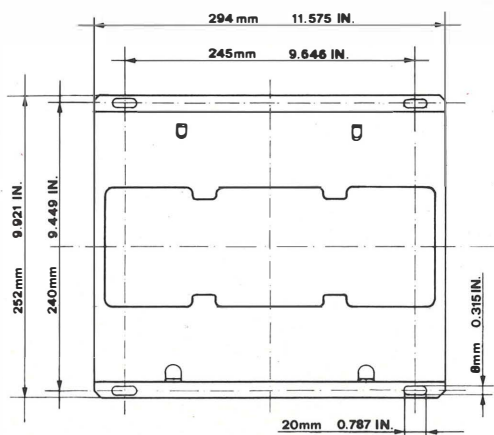

CHASSIS WITH SWITCH MODEL POWER SUPPLY INCORPORATED

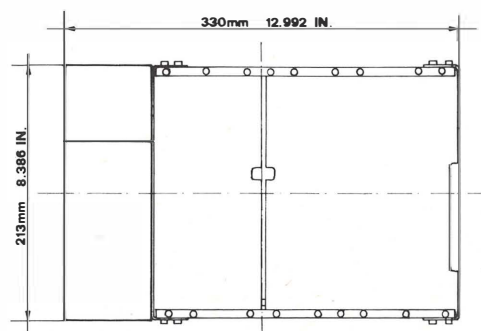

MTC 900.E 10" 90°: mechanical data

(with tiltable C.R.T.)

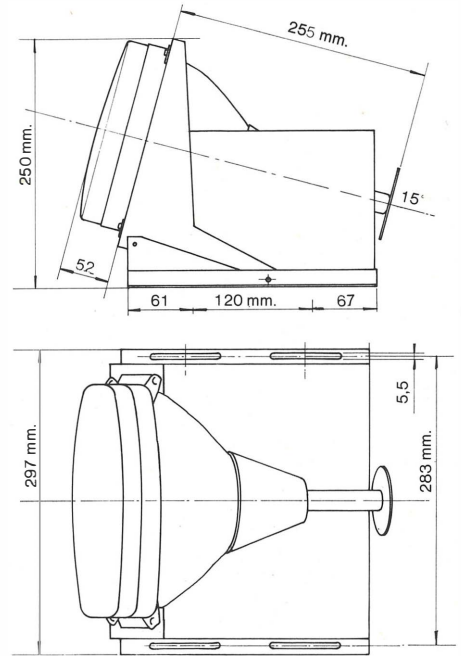
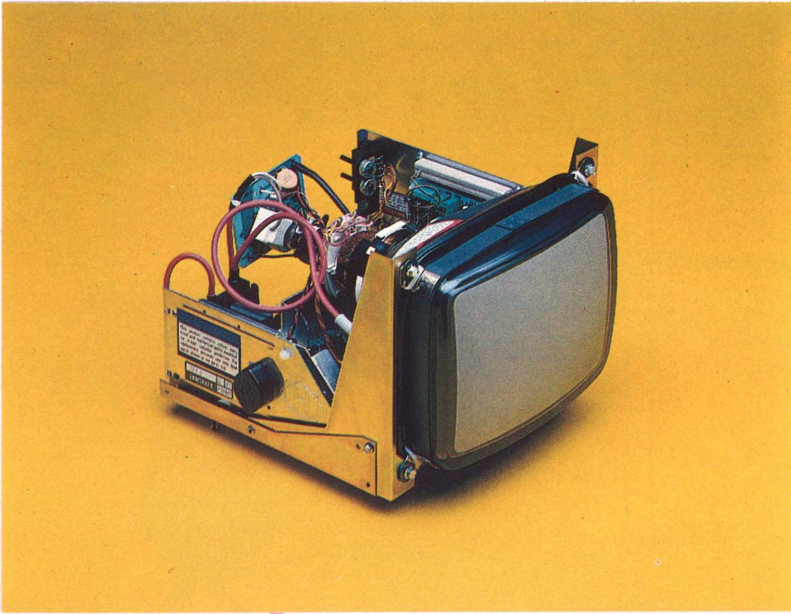

MTC 900.E 22"-26" 110°: mechanical data

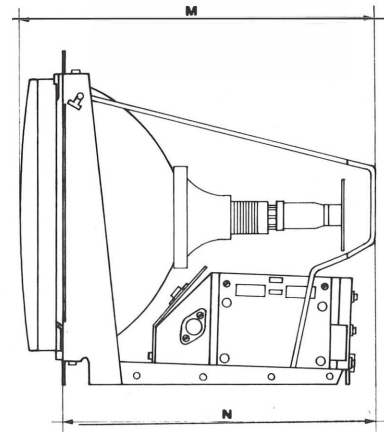
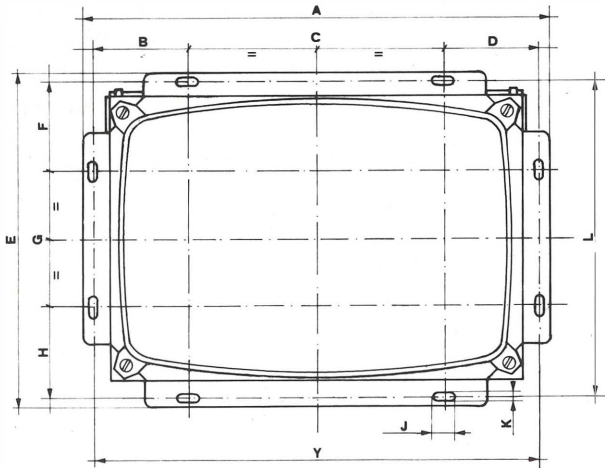

DIM.	A	B	C	D	E	F	G	H	J	K	L	M	N	Y
22" mm	560	132	280	132	449	104	225	104	20	8	433	455	385	542
26" mm	636	170	280	170	500	109	271	109	20	8	489	475	385	620
22" IN.	22.047	5.197	11.024	5.197	17.677	4.094	8.858	4.094	0.787	0.315	17.047	17.913	15.157	21.338
26" IN.	25.039	6.693	11.024	6.693	19.694	4.291	10.669	4.291	0.787	0.315	19.252	18.701	15.157	24.409

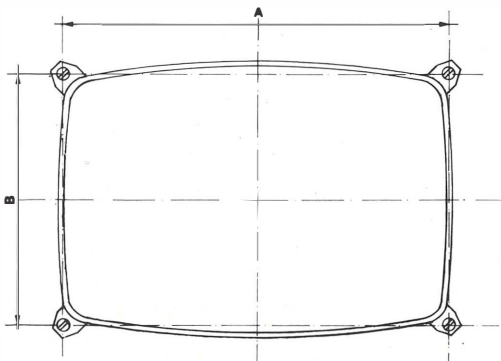

DIM.	A	B
22" mm	470	359
26" mm	542	406
22" IN.	18.504	14.134
26" IN.	21.339	15.984

MONITOR PARTS LIST

DE DEFLECTION		code 62001591	
CODE	DESCRIPTION	REF. NO.	QTY.
20100010	DIODE BA 159	D 29 - D 30	2
20110100	ZENER DIODE 1,3 W BZY 97 C 12	ZD 16	1
20110500	ZENER DIODE 1,3 W ZPY 110	ZD 21 - ZD 22	2
20150007	DIODE 1N 4007	D 12 - D 15 - D 17	3
20150170	DIODE BY V 95/C - 600	D 25 - D 27 - D 28	3
20150200	DIODE BY 448	D 13	1
20420140	TRANSISTOR BF 419	TR 10	1
20440000	THYRISTOR C 106 C	SCR	1
20620190	INTEGRATED CIRCUIT TDA 2593	IC 2	1
21215600	RESISTOR 1/4 W 5% 5,6 K Ω	R 60	1
21231000	RESISTOR 1/4 W 5% 100 Ω	R 157	1
21232700	RESISTOR 1/4 W 5% 270 Ω	R 42	1
21241000	RESISTOR 1/4 W 5% 1 K Ω	R 80	1
21241200	RESISTOR 1/4 W 5% 1,2 K Ω	R 52	1
21241500	RESISTOR 1/4 W 5% 1,5 K Ω	R 85	1
21242200	RESISTOR 1/4 W 5% 2,2 K Ω	R 91	1
21243300	RESISTOR 1/4 W 5% 3,3 K Ω	R 50 - R 55	2
21243900	RESISTOR 1/4 W 5% 3,9 K Ω	R 158	1
21244700	RESISTOR 1/4 W 5% 4,7 K Ω	R 205	1
21251200	RESISTOR 1/4 W 5% 12 K Ω	R 40	1
21251202	METAL FILM RESISTOR 1/4 W 1% 12 K Ω MR 25	R 47	1
21251800	RESISTOR 1/4 W 5% 18 K Ω	R 150	1
21252200	RESISTOR 1/4 W 5% 22 K Ω	R 173	1
21252700	RESISTOR 1/4 W 5% 27 K Ω	R 148	1
21253300	RESISTOR 1/4 W 5% 33 K Ω	R 76	1
21254700	RESISTOR 1/4 W 5% 47 K Ω	R 160 - R 53	2
21255600	RESISTOR 1/4 W 5% 56 K Ω	R 155	1
21258200	RESISTOR 1/4 W 5% 82 K Ω	R 156	1
21261000	RESISTOR 1/4 W 5% 100 K Ω	R 48	1
21261200	RESISTOR 1/4 W 5% 120 K Ω	R 147	1
21262200	RESISTOR 1/4 W 5% 220 K Ω	R 39 - R 54	2
21265600	RESISTOR 1/4 W 5% 560 K Ω	R 159	1
21272200	RESISTOR 1/4 W 5% 2,2 M Ω	R 92	1
21305000	RESISTOR 1/2 W 5% 0,5 Ω	R 116	1
21311201	METAL FILM RESISTOR 1/2 W 2% 1,2 Ω PH VR 37	R 78	1
21321000	RESISTOR 1/2 W 5% 10 Ω	R 44 - R 131	2
21321200	RESISTOR 1/2 W 5% 12 Ω	R 45	1
21332200	RESISTOR 1/2 W 5% 220 Ω	R 49 - R 57 - R 96	3
21333300	RESISTOR 1/2 W 5% 330 Ω	R 51 - R 154	2
21334700	RESISTOR 1/2 W 5% 470 Ω	R 105	1
21342200	RESISTOR 1/2 W 5% 2,2 K Ω	R 200	1
21351000	RESISTOR 1/2 W 5% 10 K Ω	R 149 - R 172	2
21354700	RESISTOR 1/2 W 5% 47 K Ω	R 107	1
21362200	RESISTOR 1/2 W 5% 220 K Ω	R 77 - R 174	2
21402200	RESISTOR 1 W 10% 0, 22 Ω VTM 200-0	R 106	1
21411000	RESISTOR 1 W 5% 1 Ω RESISTA WK 4	R 152	1
21411500	RESISTOR 1 W 5% 1,5 Ω	R 87	1
21422200	RESISTOR 1 W 5% 22 Ω	R 108	1
21461000	RESISTOR 1 W 5% 100 K Ω	R 170	1
21522200	METAL OXIDE RESISTOR 2 W 5% 22 Ω	R 56	1
21641000	RESISTOR 3 W 5% 1 K Ω RESISTA WK 8	R 109	1
21746800	METAL OXIDE RESISTOR 4 W 5% 6,8 K Ω	R 94	1
22342200	AXIAL WIREWOUND RESISTOR 7 W 5% 2,2 K Ω	R 97	1
22541000	VERTICAL WIREWOUND RESISTOR 11 W 10% 1 K Ω	R 110	1
23031000	TRIMMER PT 10 H 100 Ω	RV 16	1
23041000	TRIMMER PT 15 NH 1 K Ω	RV 23	1
23054703	TRIMMER PT 15 NH 47 K Ω	RV 13 - RV 14	2
23061002	TRIMMER PT 10 H 100 K Ω	RV 17	1
23062201	TRIMMER PT 15 NH 220 K Ω	RV 15	1
24314700	ELECTROLYTIC CAPACITOR EN 12.35 4,7 μF 16 V	C 40 - C 65	2
24331000	ELECTROLYTIC CAPACITOR EN 12.35 100 μF 16 V	C 23 - C 94 - C 98	3
24342200	ELECTROLYTIC CAPACITOR EN 12.35 2200 μF 16 V	C 60	1
24421000	ELECTROLYTIC CAPACITOR EN 12.35 10 μF 25 V	C 55	1
24431000	ELECTROLYTIC CAPACITOR EN 12.35 100 μF 25 V	C 85	1
24541000	ELECTROLYTIC CAPACITOR EN 12.35 1000 μF 35 V	C 31 - C 33	2
24612200	ELECTROLYTIC CAPACITOR EN 12.35 2,2 μF 63 V	C 32 - C 66	2
24914700	ELECTROLYTIC CAPACITOR EN 12.35 4,7 μF 250 V	C 54	1
24924702	ELECTROLYTIC CAPACITOR EN 12.35 47 μF 250 V	C 72 - C 97	2
25144701	POLYESTER CAPACITOR 4,7 nF 2,5% 63 V 1.42	C 35	1
25262200	POLYESTER CAPACITOR 220 nF 10% 100 V 1.60	C 41 - C 61 - C 86	3
25264700	POLYESTER CAPACITOR 470 nF 10% 100V 1.60	C 48 - C 57 - C 99	3
25266800	POLYESTER CAPACITOR 680 nF 10% 100 V 1.60	C 42	1
25361001	POLYESTER CAPACITOR 100 nF 10% 160 V 1.60	C 45 - C 200	2
25444700	POLYESTER CAPACITOR 4,7 nF 10% 250 V 1.60	C 118	1
25451000	POLYESTER CAPACITOR 10 nF 10% 250 V 1.60	C 37 - C 24	2
25452200	POLYESTER CAPACITOR 22 nF 10% 250 V 1.60	C 63	1
25461010	POLYESTER CAPACITOR 100 nF 10% 250 V 1.60	C 43 - C 47 - C 49	3
25464710	POLYESTER CAPACITOR 470 nF 10% 250 V 1.76	C 69	1
25472200	POLYESTER CAPACITOR 2,2 μF 10% 250 V 1.60	C 64	1
25646800	POLYESTER CAPACITOR 6,8 nF 10% 630 V 1.60	C 58	1
25653301	POLYESTER CAPACITOR 33 nF 10% 630 V 1.60	C 75	1
25741000	POLYESTER CAPACITOR 1 nF 10% 1000 V 1.60	C 34	1
25944700	POLYESTER CAPACITOR 4,7 nF 5% 1750 V 1,73	C 70	1
25945600	POLYESTER CAPACITOR 5,6 nF 5% 1750 V 1,73	C 59 - C 73	2
26310100	CERAMIC CAPACITOR 100 pF 5% 50 V NPO	C 56	1
26322400	CERAMIC CAPACITOR 220 pF 10% 1000 V	C 74 - C 88 - C 93	3
26422608	CERAMIC CAPACITOR 2200 pF - 20 + 50 500 V 511.1	C 62	1
26610601	CERAMIC CAPACITOR 100000 pF - 20 + 80 50V	C 30 - C 67 - C 77	3
28010080	DRIVER TRANSFORMER MTC 90 PL. 557 50050200	TH 2	1
28010251	EHT TRANSFORMER OREGA DST 3700401	TH 3	1
28020200	CHOKER 8 mH WITH FERRITE CORE	B 3	1
28040020	LINEARITY COIL PLESSEY 51716313300	B 4	1
28060337	AMPLITUDE COIL 523920903	B 5	1
50142930	PRINTED CIRCUIT DE		1

PE INTERFACE		code 62001501	
CODE	DESCRIPTION	REF. NO.	QTY.
20100000	DIODE 1N4148	D 5 - D 9 - D 23 - D 24 - D 26 - D 33	6
20100010	DIODE BA 159	D 6 - D 8 - D 34	3
20110100	ZENER DIODE 1,3 W BZY 97 C 12	ZD 15	1
20110200	ZENER DIODE 1,3 W ZY 7,5	ZD 7	1
20150007	DIODE 1N4007	D 14 - D 20	2
20150130	DIODE BY 255	D 1 - D 2 - D 3 - D 4	4
20400403	TRANSISTOR BC 557 B	TR 12 - TR 13 - TR 14 - TR 15 - TR 16 - TR 35	6
20400422	TRANSISTOR BC 547 B	TR 1 - TR 7 - TR 8 - TR 11 - TR 18 - TR 19 - TR 20 - TR 21 - TR 22 - TR 23 - TR 24 - TR 25 - TR 36 - TR 37	14
20420500	TRANSISTOR BF 871	TR 6	1
20420510	TRANSISTOR BF 872	TR 5	1
20620071	INTEGRATED CIRCUIT MA 7905	IC 1	1
21000307	POSISTOR 2322.662.98009	PTC	1
21215600	RESISTOR 1/4 W 5% 5,6 Ω	R 114 - R 115 - R 117	3
21221500	RESISTOR 1/4 W 5% 15 Ω	R 164 - R 165 - R 166	3
21222200	RESISTOR 1/4 W 5% 22 Ω	R 63 - R 64 - R 119	3
21231000	RESISTOR 1/4 W 5% 100 Ω	R 16 - R 26 - R 79	3
21231200	RESISTOR 1/4 W 5% 120 Ω	R 35 - R 36 - R 37	3
21232700	RESISTOR 1/4 W 5% 270 Ω	R 104 - R 112 - R 113	3
21234700	RESISTOR 1/4 W 5% 470 Ω	R 38 - R 81 - R 82	3
21241000	RESISTOR 1/4 W 5% 1 K Ω	R 1 - R 5 - R 7 - R 8 - R 41 - R 43 - R 46 - R 58 - R 68 - R 83 - R 84 - R 88 - R 89 - R 90 - R 93 - R 99 - R 100	17
21241200	RESISTOR 1/4 W 5% 1,2 K Ω	R 75	1
21244700	RESISTOR 1/4 W 5% 4,7 K Ω	R 3 - R 10	2
21251000	RESISTOR 1/4 W 5% 10 K Ω	R 4	1
21251500	RESISTOR 1/4 W 5% 15 K Ω	R 27 - R 28 - R 31	3
21252200	RESISTOR 1/4 W 5% 22 K Ω	R 101 - R 102 - R 103 - R 203	4
21254700	RESISTOR 1/4 W 5% 47 K Ω	R 73	1
21261000	RESISTOR 1/4 W 5% 100 K Ω	R 32 - R 33 - R 34	3
21312200	RESISTOR 1/2 W 5% 2,2 Ω	R 121	1
21324700	RESISTOR 1/2 W 5% 47 Ω	R 25	1
21328200	RESISTOR 1/2 W 5% 82 Ω	R 19	1
21341000	RESISTOR 1/2 W 5% 1 K Ω	R 21 - R 29 - R 71	3
21342200	RESISTOR 1/2 W 5% 2,2 K Ω	R 22	1
21343300	RESISTOR 1/2 W 5% 3,3 K Ω	R 23	1
21355600	RESISTOR 1/2 W 5% 56 K Ω	R 18	1
21361200	RESISTOR 1/2 W 5% 120 K Ω	R 20	1
21407500	RESISTOR 1 W 5% 0,75 Ω	R 30	1
21444700	RESISTOR 1 W 5% 4,7 K Ω	R 69	1
21451000	RESISTOR 1 W 5% 10 K Ω	R 66	1
21652200	RESISTOR 3 W 5% 22 k Ω RESISTA WK 8	R 24	1
22312200	AXIAL WIREWOUND RESISTOR 5 W 10% 220 Ω	R 175	1
23041000	TRIMMER PT 15 NH 1 K Ω	RV 1 - RV 2 - RV 3	3
23042203	TRIMMER PT 15 V 2,2 K Ω	RV 12	1
23051004	TRIMMER PT 15 NH 10 K Ω	RV 10	1
24314700	ELECTROLYTIC CAPACITOR EN 12.35 4,7 μF 16V	C 18 - C 19 - C 20	3
24321000	ELECTROLYTIC CAPACITOR EN 12.35 10 μF 16 V	C 21 - C 22 - C 27 - C 29 - C 38 - C 39 - C 4 - C 5 - C 6	9
24324700	ELECTROLYTIC CAPACITOR EN 12.35 47 μF 16 V	C 25	1
24331000	ELECTROLYTIC CAPACITOR EN 12.35 100 μF 16 V	C 7 - C 8 - C 9	3
24424700	ELECTROLYTIC CAPACITOR EN 12.35 47 μF 25 V	C 83	1
24522200	ELECTROLYTIC CAPACITOR EN 12.35 22 μF 35 V	C 36	1
24933302	ELECTROLYTIC CAPACITOR 330 μF 200 V	C 11	1
25751002	POLYESTER CAPACITOR 10 nF 10% 250 VCA 1.58	C 3	1
25754701	POLYESTER CAPACITOR 47 nF 10% 250 VCA 1.58	C 1	1
25761002	POLYESTER CAPACITOR 100 nF 10% 250 VCA 1.58	C 2	1
26222100	CERAMIC CAPACITOR 22 pF 5% 50 V NPO	C 15 - C 16 - C 17	3
26310100	CERAMIC CAPACITOR 100 pF 5% 50 V NPO	C 10 - C 13 - C 14	3
26410803	CERAMIC CAPACITOR 1000 pF 10% 50 V	C 12	1
26510601	CERAMIC CAPACITOR 10000 pF - 20 + 80 50 V	C 26	1
26610601	CERAMIC CAPACITOR 100000 pF - 20 + 80 50 V	C 71 - C 78 - C 79	3
29100000	FUSE 2AT	F 1 - F 2	2
29100009	FUSE 3,15 AT	F 3	1
50143180	PRINTED CIRCUIT PE		1

NF C.R.T. BASE

code 62001581

CODE	DESCRIPTION	REF. NO.	QTY.
20100000	DIODE 1N4148	D 10 - D 11 - D 18 - D 19 - D 31 - D 32	6
20400422	TRANSISTOR BC 547 B	TR 26 - TR 29 - TR 32	3
20420500	TRANSISTOR BF 871	TR 27 - TR 28 - TR 30 - TR 31 - TR 33 - TR 34	6
21224700	RESISTOR 1/4 W 5% 47 Ω	R 167 - R 168 - R 169	3
21231000	RESISTOR 1/4 W 5% 100 Ω	R 128 - R 129 - R 130	3
21236800	RESISTOR 1/4 W 5% 680 Ω	R 122 - R 124 - R 126	3
21238200	RESISTOR 1/4 W 5% 820 Ω	R 123 - R 125 - R 127	3
21335600	RESISTOR 1/2 W 5% 560 Ω	R 139 - R 140 - R 142	3
21342200	RESISTOR 1/2 W 5% 2,2 K Ω	R 59	1
21343300	RESISTOR 1/2 W 5% 3,3 K Ω	R 141 - R 143 - R 146	3
21424700	RESISTOR 1 W 5% 47 Ω	R 145	1
21512700	RESISTOR 2 W 5% 2,7 Ω RESISTA WK5	R 144	1
21551800	RESISTOR 2 W 5% 18 K Ω RESISTA WK 5	R 136 - R 137 - R 138	3
21553300	METAL OXIDE RESISTOR 2 W 5% 33 K Ω	R 133 - R 134 - R 135	3
23034703	TRIMMER PT 10 H 470 Ω	RV 4 - RV 5 - RV 6 - RV 7 - RV 8 - RV 9	6
24321000	ELECTROLYTIC CAPACITOR EN 12.35 10 μ F 16 V	C 50	1
24914700	ELECTROLYTIC CAPACITOR EN 12.35 4,7 μ 250 V	C 51	1
25461000	POLYESTER CAPACITOR 100 nF 10% 250 V 1.60	C 52	1
26247100	CERAMIC CAPACITOR 47 pF 5% 50 V NPO	C 28 - C 60 - C 68	3
26468720	CERAMIC CAPACITOR 6800 pF 20% 2000 V 507.6	C 53	1
26510601	CERAMIC CAPACITOR 10000 pF - 20 + 80 50 V	C 44 - C 46	2
28020130	CHOKE 10 μ H WITH FERRITE CORE	B 6	1
50143820	C.R.T. BASE NF		1

HEAT SINK ASSEMBLY

code 62000614

CODE	DESCRIPTION	REF. NO.	QTY.
20430200	TRANSISTOR BU 208 A	TR 17	1
22621000	AXIAL WIREWOUND RESISTOR 15 W 10% 10 Ω	R 98	1
34020211	SOCKET FOR TRANSISTOR T03 HANTAREX IN DURETHANBKW30 N1		1

POWER UNIT HEAT SINK ASSEMBLY

code 62001511

CODE	DESCRIPTION	REF. NO.	QTY.
20430430	TRANSISTOR HANTAREX 20430430	TR 9	1
22932200	AXIAL WIREWOUND RESISTOR 30 W 10% 220 Ω	R 17	1

VERT. DEFLECTION HEAT SINK ASSEMBLY

code 62001390

CODE	DESCRIPTION	REF. NO.	QTY.
20620080	INTEGRATED CIRCUIT MA 7812	IC 4	1
20620270	INTEGRATED CIRCUIT TDA 2653 A	IC 3	1
40029065	SELF TAPPING SCREW 2,9 x 6,5 TCC		1
43000010	BELT SPRING 3 x 030		1
50111530	ALUMINIUM HEAT SINK		1

PRINTED CIRCUIT BOARD

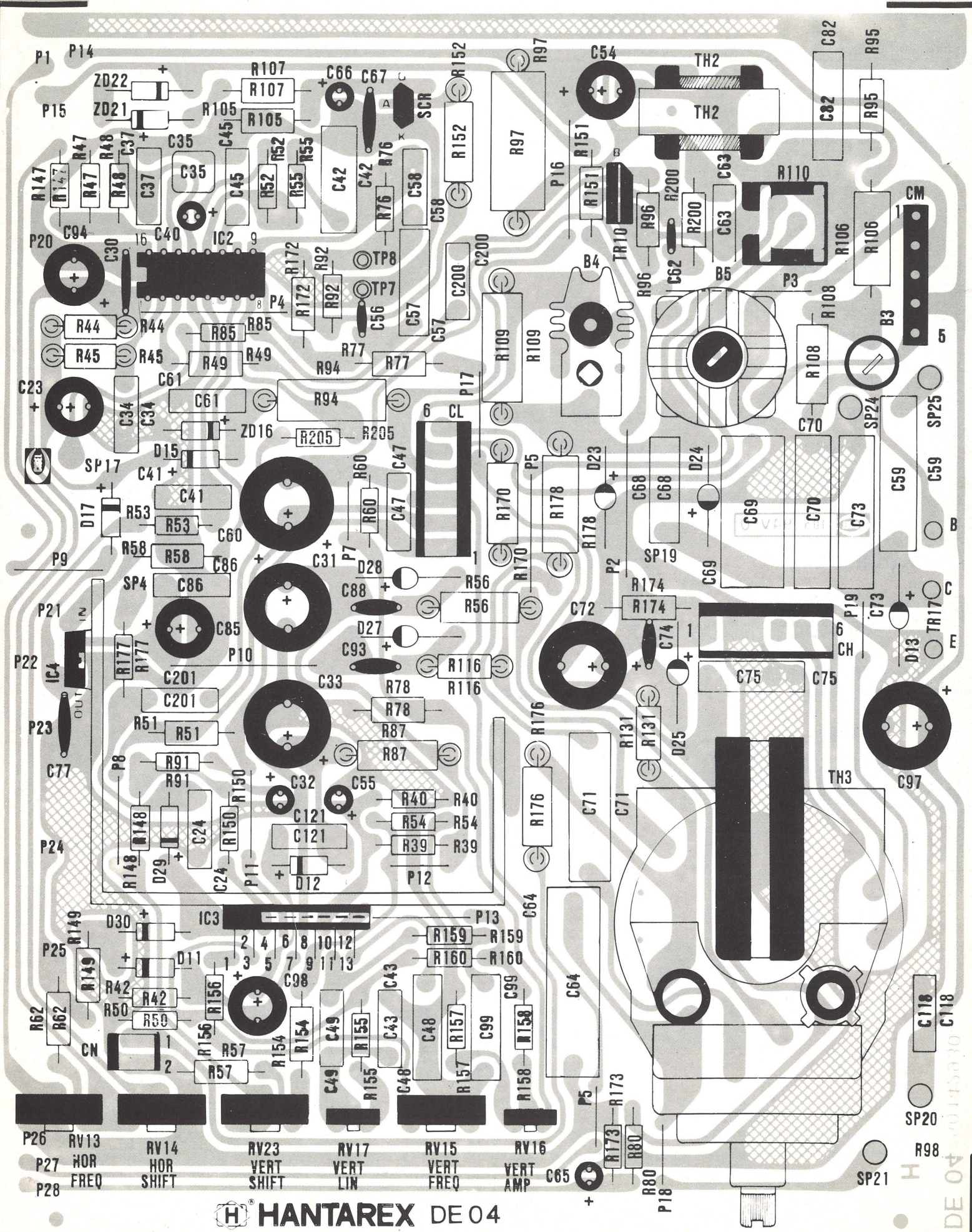

HANTAREX DE 04

DE 04 (0150) 30

INTERFACE BOARD PE

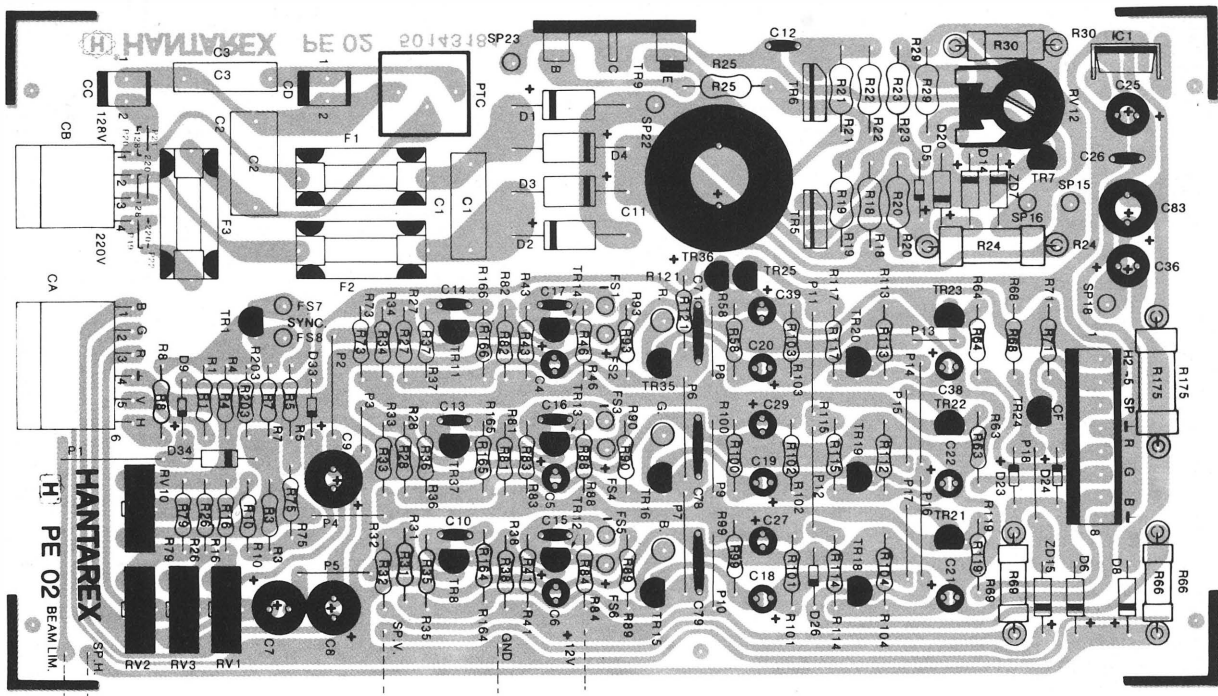

NECK BOARD NE

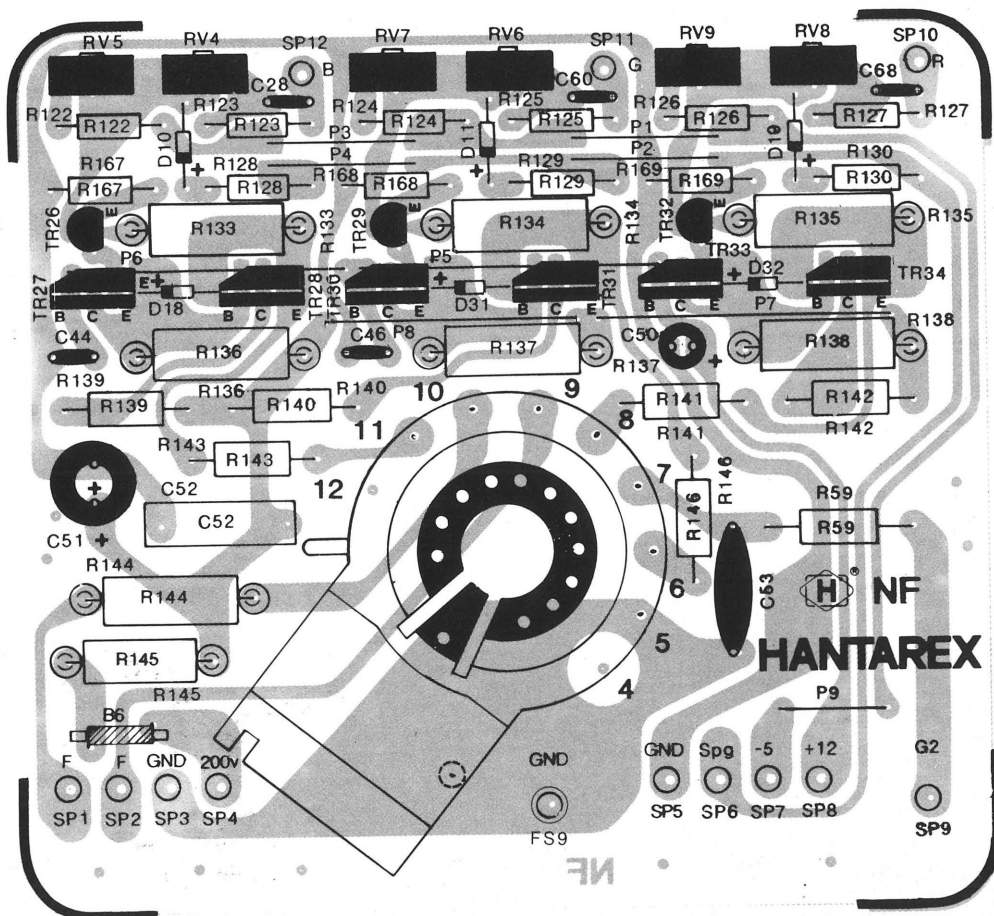

WAVEFORMS

SCHEMATIC DIAGRAM

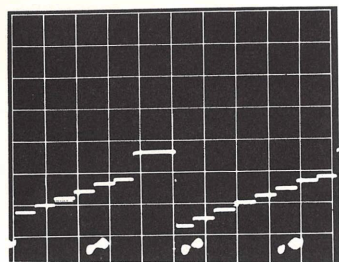

50V div 10µs div

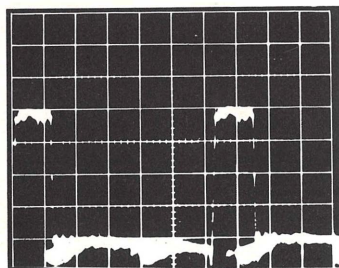

500 mV div 10µs div

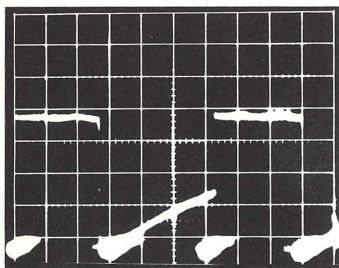

1V div 10µs div

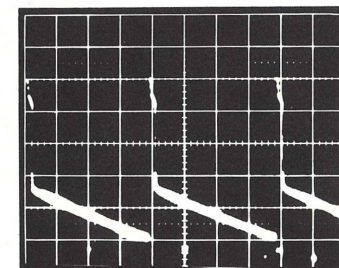

10 Vpp div 5 mS div

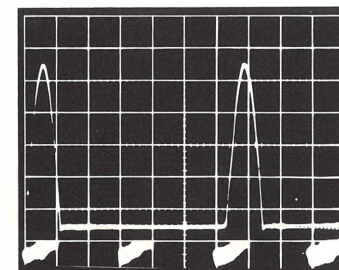

200 Vpp div 10µs div

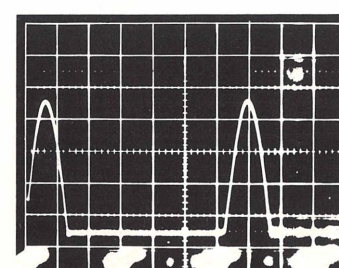

200 Vpp div 10µs div

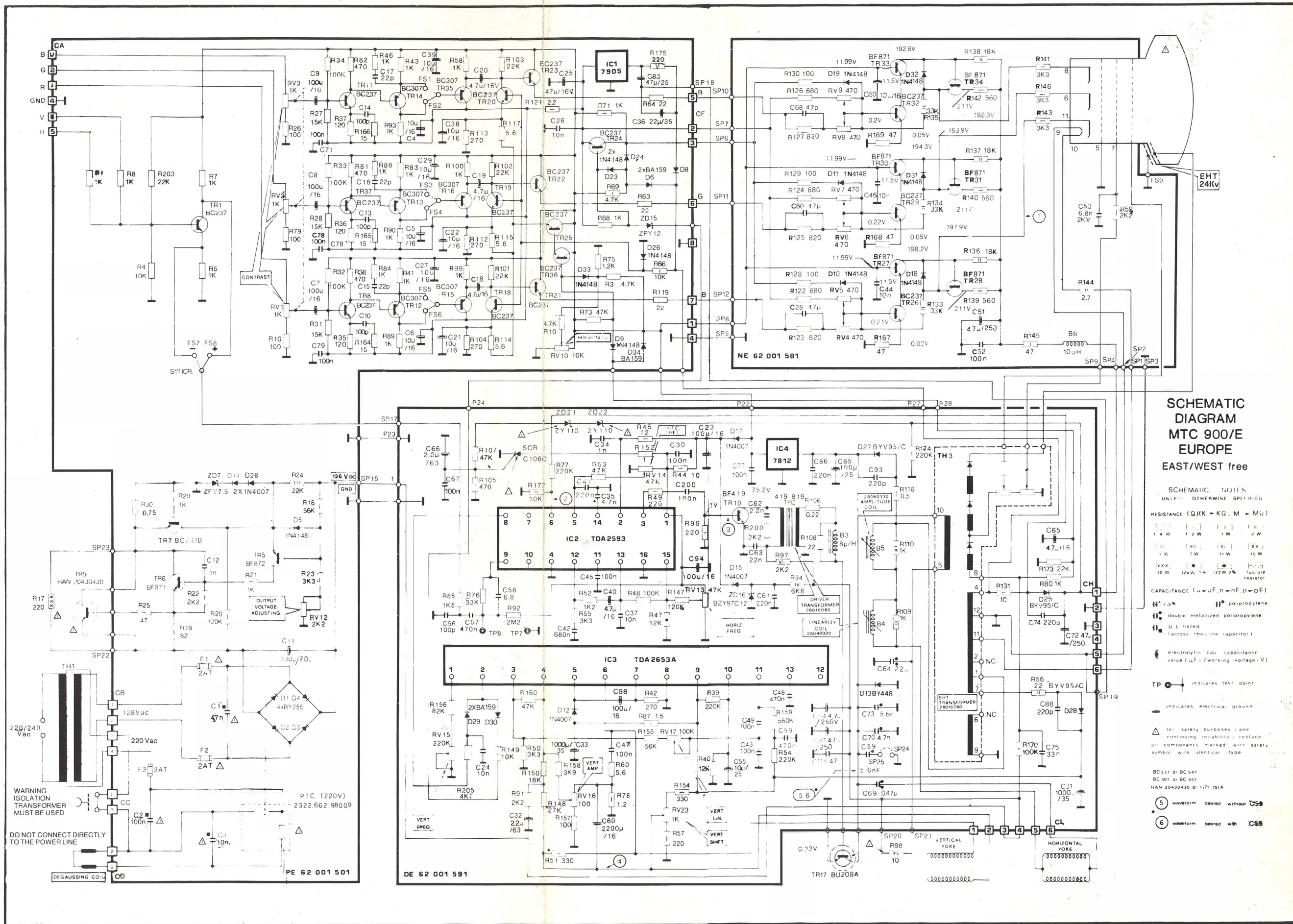

SCHEMATIC DIAGRAM MTC 900/E EUROPE EAST/WEST free

SCHEMATIC NOTES
UNLESS OTHERWISE SPECIFIED

RESISTANCE (Ω/K/KΩ/M/MΩ)

1/4 W	1/2 W	1 W	2 W
3 W	7 W	11 W	15 W
10 W	1/4 W 2%	1/2 W 2%	1 W 2%

FUSIBLE RESISTOR

CAPACITANCE (µ=µF, n=nF, p=pF)

7.5% 1% polypropylene
 double metallized polypropylene
 U.L. listed
 across-the-line capacitor

electrolytic cap. capacitance value (µF/working voltage(V))

TP indicates test point

indicates electrical ground

for safety purposes (and continuing reliability) replace all components marked with safety symbol with identical type

BC237 or BC547
 BC307 or BC557
 HAN 20430430 or 11P 151A

5 waveform biased without CS9
 6 waveform biased with CS9

HANTAREX VIDEOGAMES DIVISION

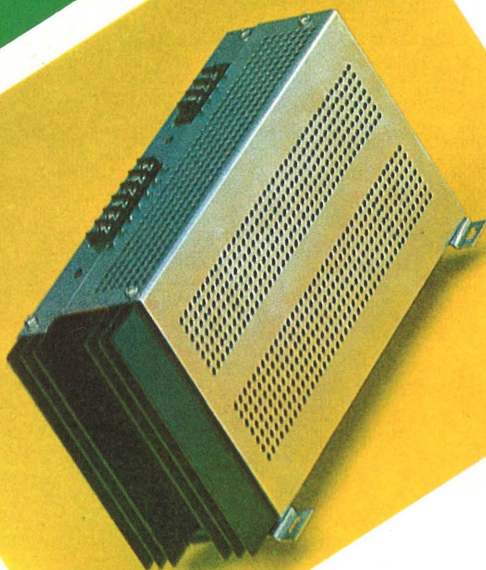

US 100
Alimentatore basse tensioni per Piastre della Logica
Low voltage Power Unit for Logic Board
AC 117/240+5V.7A/-5V.1A/+12V.1.5A/-12V.0.5A

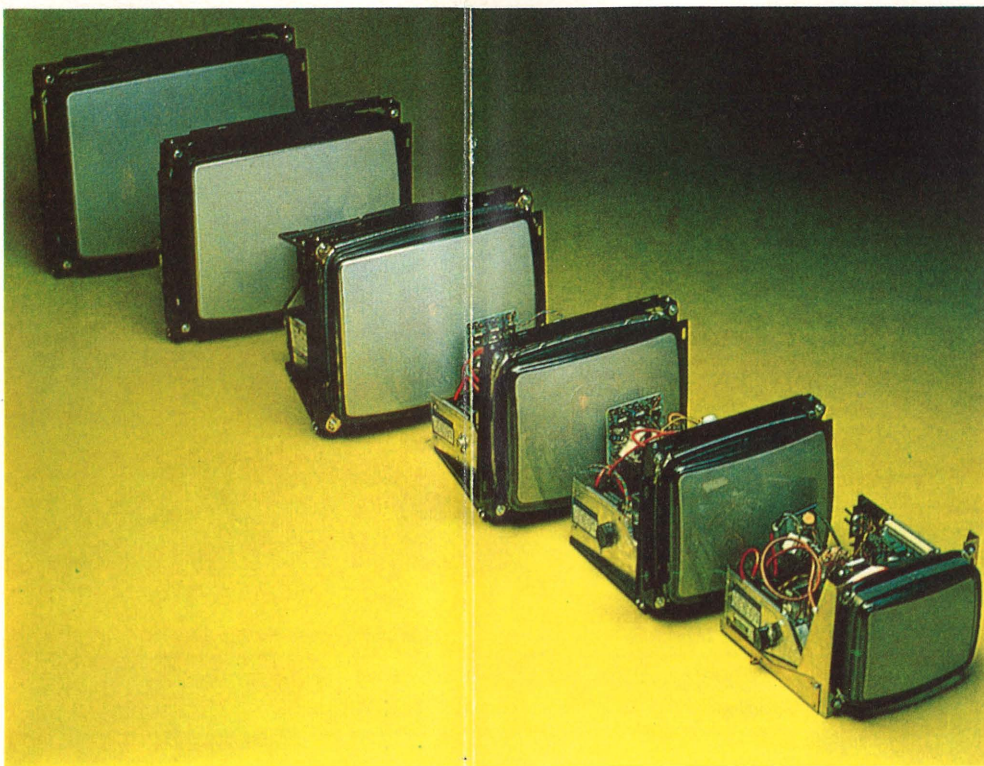

MTC 900 E colour monitor
10" - 14" - 16" - 20" - 22" - 26" - 110"

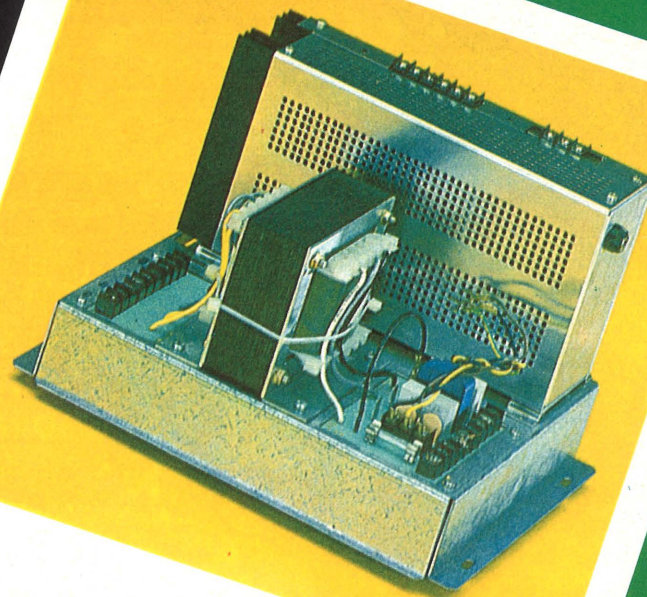

ALIMENTATORE UNIVERSALE PSB 100A - permette l'alimentazione del monitor-colore, delle lampade della gettoniera, dei neon, e di supportare l'alimentatore Switch US 100
UNIVERSAL POWER UNIT PSB 100A - supplies the colour monitor, coin mechanism lamps, neons and feeds the Switch-Mode Power Supply US 100.



CABLAGGIO UNIVERSALE - permette di gestire qualsiasi tipo di Logic-Board per videogames
UNIVERSAL CABLEFORM - permits use of almost any type of videogames Logic Board

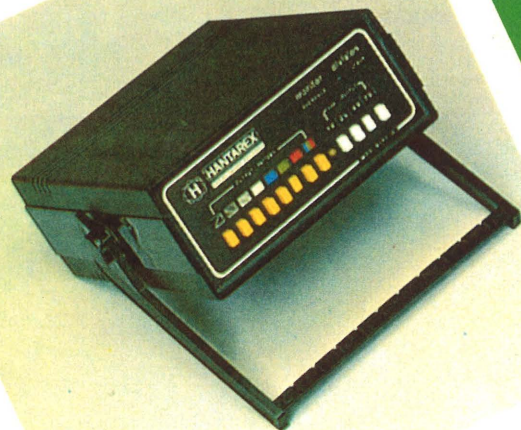

K 190 G
Generatore di segnali RGB per il controllo e la messa a punto di monitors a colori
RGB signal generator for testing and setting-up colour monitors

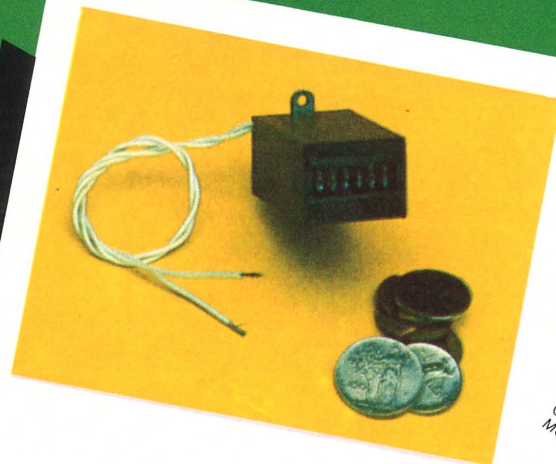

CONTATORE - con sei cifre, disponibile a 12 o 6 Vdc
COUNTER - with six digits, available for 12 or 6 Vdc operation

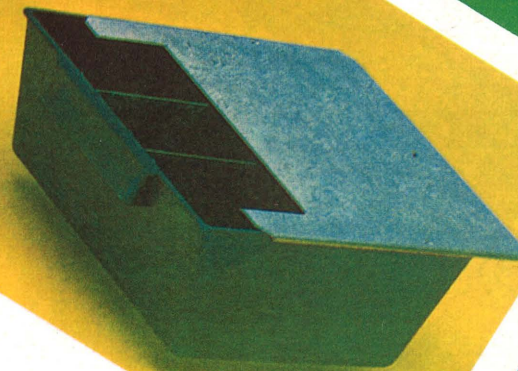

CASSETTA PORTAMONETE - con separatori interni per 2 o 3 gettoniere
MONEY-BOX - with internal dividers for two or three coin sizes



HANTAREX®

QUALITY . RELIABILITY . SERVICE

Electronic
Equipment
Manufacturer

50134 FIRENZE - Italy - 30, Via Riguccio Galluzzi - tel. 055/483176.7.8.9 - telex 572341 Hantar - I

cod. 53870 035 (05/86)

MODIFICHE RELATIVE ALL'IMPIEGO DEL CINESCOPIO ORION 20'' TIPO 510UDB22 CON CIRCUITO EST/OVEST

ATTENZIONE: per il corretto funzionamento del cinescopio 20'' ORION 510UDB22 deve essere impiegato un telaio provvisto di circuito di correzione «EST/OVEST» tipo **EW**. Non è possibile impiegare il cinescopio ORION 510UDB22 con un telaio MTC 900/E che non abbia il suddetto circuito.

Questa elettronica provvista di circuito «EST/OVEST» può essere però montata anche sui cinescopi (non ORION) da 14-16-20 pollici precedentemente impiegati tipo: A51-421X-231X-420X ecc.; in questo caso, risulterà al momento dell'accensione un evidente effetto «botte» causato da una sovracorrezione; per il corretto funzionamento, basterà ruotare **RV 19** fino ad avere i lati destro e sinistro verticali e paralleli.

Qualora vi fosse la necessità di impiegare questo telaio provvisto di circuito «EST/OVEST» con cinescopi dotati di attacco «**S4**» si rende necessaria la sostituzione dello zoccolo **CRT** del circuito stampato «**NF**». Lo zoccolo con inserimento meccanico per tubi tipo «**S4**» si potrà richiedere facendo riferimento al tipo «HOSIDEN» codice Hantarex n° 50142900.

AVVERTENZE: La bobina **B5** non svolge più la funzione di regolazione dell'ampiezza orizzontale, ma diviene bobina «PONTE» del circuito «EST/OVEST», pertanto non deve essere assolutamente manomessa nel tentativo di variare l'ampiezza orizzontale. Per tale variazione basterà ruotare il trimmer **RV 20** posto sul circuito «EST/OVEST» (rif. schema EW).

Nello schema allegato potrete prendere visione delle modifiche circuitali apportate per l'aggiunta del circuito «EST/OVEST» ed anche l'elenco dei componenti per eventuali ricambi.

INFORMATION RELATING TO THE USE OF ORION CATHODE-RAY TUBE 510UDB22 ON THE HANTAREX COLOUR MONITOR MTC 900/E

For the ORION 20'' tube 510UDB22 to function correctly it must be fitted to a chassis incorporating an EAST/WEST correction circuit.

Hence, it is not possible to use the ORION 20'' 510UDB22 with an MTC 900/E chassis not incorporating an EAST/WEST correction circuit.

However, a chassis with an EAST/WEST correction circuit can be used with 14'', 16'' and 20'' tubes that themselves have pre-correction as used previously, such as types A51/421X/231X/420X etc.

*In that case, on switching-on there will obviously be barrel distortion caused by over-correction, which can be rectified simply by adjusting the setting of **RV 19** to restore the right and left hand edges of the raster to be vertical and parallel.*

*Should it be necessary to use a chassis with an EAST/WEST correction circuit together with a tube with an **S4** connector, then it will also be necessary to substitute the Cathode-Ray Tube socket connector on the «**NF**» printed circuit board for a HOSIDEN connector, HANTAREX code number 50142900.*

*When the EAST/WEST correction circuit is fitted, it is important to note that inductance **B5** functions as a bridge inductance in the EAST/WEST circuit, and under no circumstances is it to be used for adjusting amplitude.*

*Amplitude adjustment is only to be effected by adjustment of **RV 20** situated on the EAST/WEST correction circuit.*

The accompanying circuit diagram shows the circuit changes that are brought about by the introduction of EAST/WEST correction, and there is also a list of the additional components.



HANTAREX®

Electronic
Equipment
Manufacturer

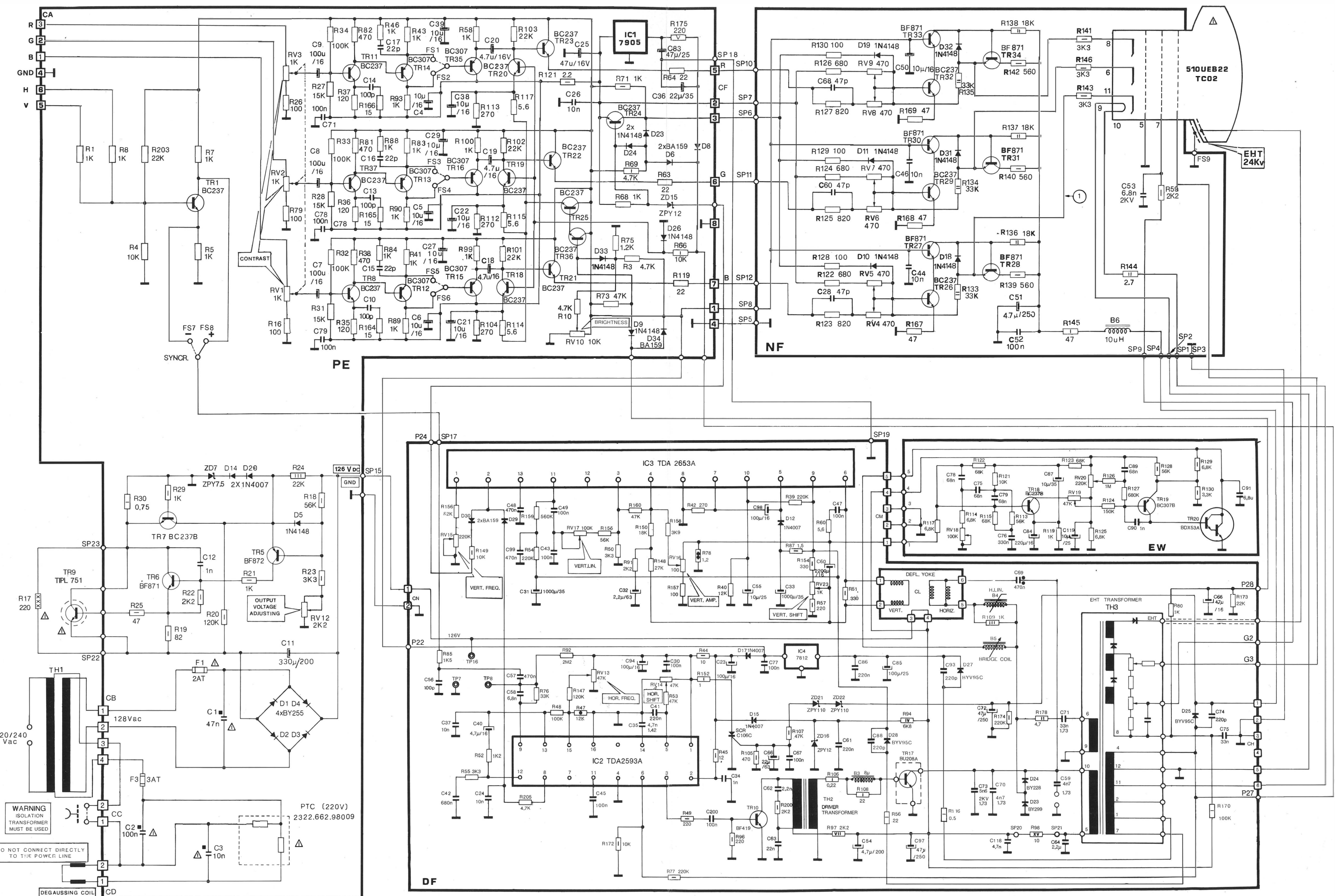

MTC900/E
SCHEMATIC DIAGRAM

PART LIST «EAST/WEST»

CODE	DESCRIPTION	QTY.	REF. N°
20400402	TRANS. BC 307 B	1,00	TR 19
20400420	TRANS. BC 237 B	1,00	TR 18
20410100	TRANS. BDX 53 A	1,00	TR 20
21241000	CARBON RESISTOR 1K 5% 1/4W	1,00	R 119
21246800	CARBON RESISTOR 6,8K 5% 1/4W	3,00	R 114-117-125
21251000	CARBON RESISTOR 10K 5% 1/4W	1,00	R 121
21255600	CARBON RESISTOR 56K 5% 1/4W	1,00	R 113
21256800	CARBON RESISTOR 68K 5% 1/4W	3,00	R 115-122-123
21261500	CARBON RESISTOR 150K 5% 1/4W	1,00	R 124
21266800	CARBON RESISTOR 680K 5% 1/4W	1,00	R 127
21271000	CARBON RESISTOR 1M 5% 1/4W	1,00	R 126
21343300	CARBON RESISTOR 3,3K 5% 1/2W	1,00	R 130
21346800	CARBON RESISTOR 6,8K 5% 1/2W	1,00	R 129
21355600	CARBON RESISTOR 56K 5% 1/2W	1,00	R 128
23054702	TRIMMER 47K VERT. PT10H	1,00	RV 19
23061002	TRIMMER 100K VERT. PT10H	1,00	RV 18
23062202	TRIMMER 220K VERT. PT10H	1,00	RV 20
24332200	ELECTROLYTIC CAPACITOR 220 MF 16V	1,00	C 84
24521000	ELECTROLYTIC CAPACITOR 10 MF 35V	2,00	C 87-119
25276800	MKT CAPACITOR 6,8 MF 100V 1.60 10% P 27,5	1,00	C 91
25363300	MKT CAPACITOR 330 NF 160V 1.60 20% P 15	1,00	C 76
25456800	MKT CAPACITOR 68 NF 250V 1.60 10% P 10	4,00	C 75-78-79-89
25741000	MKT CAPACITOR 1NF 1000V 1.60 10% P 10	1,00	C 90
33617500	JUMP L= 7,5	1,00	P 2
33621250	JUMP L= 12,5	2,00	P 1-3
34021305	CONNECTOR 6630/5D	1,00	CM
50114920	DISS.X TO 220 EAST-OVEST UTH1347	1,00	
50142251	C.S.E.W. MTC900 EW	1,00	

MODIFICHE RELATIVE AL CIRCUITO ELETTRICO DELLA DEFLESSIONE «DF» CON AGGIUNTA DEL CIRCUITO «EST/OVEST»

MODIFICATION TO THE DEFLEXION CIRCUIT «DF» USED WITH THE «EAST/WEST» CIRCUIT

P3 - Jump 25 mm.	cod. 33622500
B5 - Bridge Coil	cod. 28020320
D24 - Diode BY 228.	cod. 20150210
D23 - Diode BY 299	cod. 20150400
R178 - Resistor 2W 4.7 Ohm	cod. 21514700
C71 - Polyester Capacitor 33 µF 1000 V. 1.73	cod. 25753303
C73 - Polyester Capacitor 5.6 µF 1750 V. 1.73	cod. 25945600
C59-C70 - Polyester Capacitor 4.7 µF 1750 V. 1.73 ...	cod. 25944700

COMPONENTI ELIMINATI COMPONENTS ELIMINATED

D 13 — R 110