



ROLLING THUNDER



ROLLING THUNDER IS ENGINEERED AND DESIGNED BY NAMCO LTD.
MANUFACTURED BY ATARI GAMES. TRADEMARK AND © NAMCO 1986.

Operators Manual

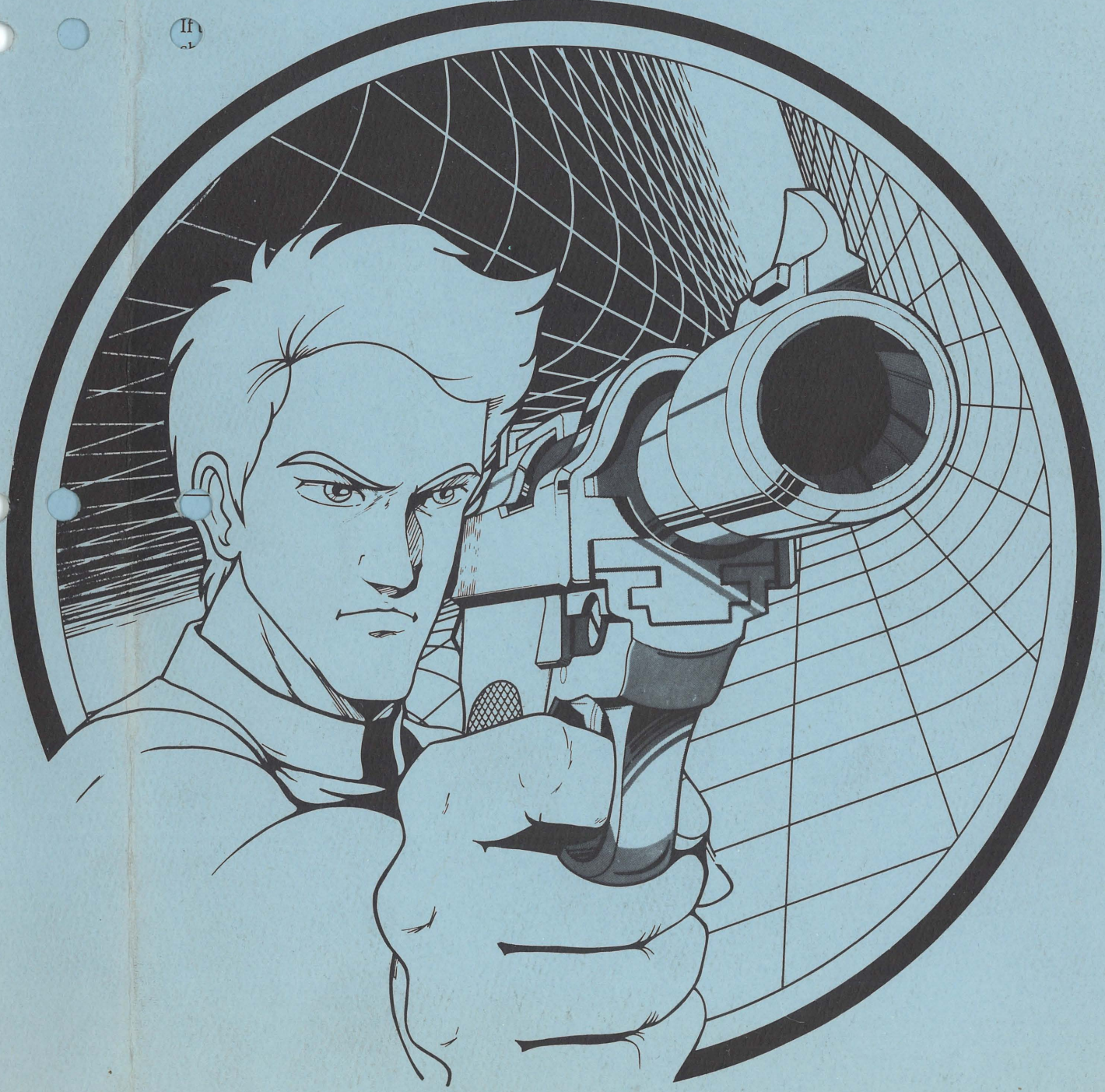

If
at

For technical assistance:

If reading through this manual does not lead to solving a maintenance or repair problem, call TELEHELP® at one of these Atari Games Customer Service offices:

UNITED STATES

Atari Games Corporation
California Customer Service Office
737 Sycamore Drive
P.O. Box 361110
Milpitas, CA 95035

Fax (408) 434-3945

Telex 5101007850

(Monday-Friday, 7:30-4:00 pm Pacific Time)

☎ (408) 434-3950

EUROPE

Atari Games Ireland Limited
European Customer Service Office
Tipperary Town, Ireland

Fax 062-51702

Telex 28165

(Monday-Friday, 9:00-5:30 pm GMT)

☎ 062-52155



ROLLING* THUNDER

Operators Manual
with Illustrated Parts Lists



ATARI®
GAMES

**Rolling Thunder is engineered and designed by Namco Ltd.
Manufactured by Atari Games. Trademark and © Namco 1986.*

© 1987 by Atari Games Corporation

All rights reserved

No part of this publication may be reproduced by any mechanical, photographic, or electronic process, or in the form of a phonographic recording, nor may it be stored in a retrieval system, transmitted, or otherwise copied for public or private use, without permission from the publisher.

The game play, all graphic designs, this technical manual, its accompanying schematic diagrams, and the display manual are protected by the U.S. Copyright Act of 1976.

This Act provides for increased penalties for violating federal copyright laws. Courts *can impound* infringing articles while legal action is pending. If infringers are convicted, courts can *order destruction* of the infringing articles.

In addition, the Act provides for payment of statutory damages of up to \$250,000 in certain cases. Infringers may also have to pay costs and attorneys' fees and face an imprisonment of up to five years.

Atari Games Corporation will aggressively enforce its copyrights against any infringers. *We will use all legal means* to immediately halt any manufacture, distribution, or operation of a copy of video games made by us. Anyone who purchases such copies risks forfeiting such a game.

Published by: Atari Games Corporation
675 Sycamore Drive
P.O. Box 361110
Milpitas, California 95035

Printed in the U.S.A. **2R**

Notice Regarding Non-ATARI® Parts



WARNING



Use of non-ATARI parts or modifications of any ATARI game circuitry may adversely affect the safety of your game, and may cause injury to you and your players.

You may void the game warranty (printed on the inside back cover of this manual) if you do any of the following:

- Substitute non-ATARI parts in the game.
- Modify or alter any circuits in the game by using kits or parts *not* supplied by Atari Games Corporation.

NOTE

This equipment generates, uses, and can radiate radio frequency energy and if not installed and used in accordance with the instruction manual, may cause interference to radio communications. It has been tested and found to comply with the limits for a Class A computing device pursuant to Subpart J of Part 15 of Federal Communications Commission (FCC) Rules, which are designed to provide reasonable protection against such interference when operated in a commercial environment. Operation of this equipment in a residential area or modification to this equipment is likely to cause interference in which case the user, at his own expense, will be required to take whatever measures may be required to correct the interference. If you suspect interference from an ATARI® game at your location, check the following:

- All ground wires in the game are properly connected as shown in the game wiring diagram.
- The power cord is properly plugged into a grounded three-wire outlet.
- On games provided with an Electromagnetic Interference (EMI) ground plane, be sure the game printed-circuit boards (PCBs) are properly installed on the EMI Ground Plane.

If you are still unable to solve the interference problem, please contact Customer Service at Atari Games Corporation. See the inside front cover of this manual for service in your area.

Table of Contents

1	Set-Up	
	How to Use This Manual	1-1
	Inspecting the Game	1-2
	Control and Switch Locations	1-2
	Setting the Coin and Game Option Settings	1-3
	Game Play	1-3
2	Self-Test	
	Explanation of the Self-Test Screen	2-2
	Service Switch	2-3
3	Maintenance	
	Preventive Maintenance	3-2
	Preventive Maintenance Intervals	3-2
	Removing the Control Panel	3-2
	Cleaning the Push-Button Leaf Switches	3-2
	Cleaning the Coin Mechanism	3-2
	Cleaning the Interior Components	3-2
	Joystick Control	3-3
	Corrective Maintenance	3-4
	Removing the Game PCB	3-4
	Removing the Video Display	3-4
	Replacing the Video Display	3-6
	Removing the Speaker	3-6
4	Illustrated Parts Lists	
	See List of Illustrations that follows.	

List of Illustrations

Figure 1-1	Control and Switch Locations	1-3
Figure 2-1	Self-Test Screen	2-2
Figure 3-1	Leaf Switch and Joystick Removal	3-3
Figure 3-2	Joystick Lubrication	3-4
Figure 3-3	Control Panel, Video Display, and Speaker Removal	3-5
Figure 4-1	Cabinet-Mounted Assemblies	4-2
Figure 4-2	Control Panel Assembly	4-5
Figure 4-3	Joystick Assembly	4-6
Figure 4-4	Switching/Linear (SL) Power Supply Assembly	4-8
Figure 4-5	Coin Acceptors, Inc. Coin Door Assembly	4-12
Figure 4-6	Rolling Thunder Game PCB and Sub PCB Assemblies	4-16
Figure 4-7	Rolling Thunder End PCB Assembly	4-21

List of Tables

Table 1-1	Game Specifications	1-2
Table 1-2	DIP Switch A Option Settings	1-5
Table 1-3	DIP Switch B Option Settings	1-5
Table 2-1	DIP Switch A Option Settings	2-4
Table 2-2	DIP Switch B Option Settings	2-4
Table 3-1	Recommended Preventive Maintenance Intervals	3-2

Safety Summary

The following safety precautions apply to all game operators and service personnel. Specific warnings and cautions will be found throughout this manual where they apply.

⚠ WARNING ⚠

Properly Ground the Game. Players may receive an electrical shock if this game is not properly grounded! To avoid electrical shock, do not plug in the game until it has been inspected and properly grounded. This game should only be plugged into a grounded three-wire outlet. If you have only a 2-wire outlet, we recommend you hire a licensed electrician to install a grounded outlet. Players may receive an electrical shock if the control panel is not properly grounded! After servicing any parts on the control panel, check that the grounding wire is firmly secured to the inside of the control panel. Only then should you lock up the game.

AC Power Connection. Before connecting the game to the AC power source, verify that the game's power supply is properly configured for the line voltage in your location.

Disconnect Power During Repairs. To avoid electrical shock, disconnect the game from the AC power source before removing or repairing any part of the game. When removing or repairing the video display, extra precautions must be taken to avoid electrical shock because high voltages may exist within the display circuitry and cathode-ray tube (CRT) even after power has been disconnected. Do not touch internal parts of the display with your hands or with metal objects! Always discharge the high voltage from the CRT before servicing this area of the game. To discharge the CRT: Attach one end of a large, well-insulated, 18-gauge jumper wire to ground. Momentarily touch the free end of the grounded jumper to the CRT anode by sliding it under the anode cap. Wait two minutes and discharge the anode again.

Use Only ATARI Parts. To maintain the safety integrity of your ATARI game, do not use non-ATARI parts when repairing the game. Use of non-ATARI parts or other modifications to the game circuitry may adversely affect the safety of your game, and injure you or your players.

Handle the CRT With Care. If you drop the CRT and it breaks, it may implode! Shattered glass can fly six feet or more from the implosion.

Use the Proper Fuses. To avoid electrical shock, use replacement fuses which are specified in the parts list for this game. Replacement fuses must match those replaced in fuse type, voltage rating, and current rating. In addition, the fuse cover must be in place during game operation.

CAUTION

Properly Attach All Connectors. Make sure that the connectors on each printed-circuit board (PCB) are properly plugged in. Note that they are keyed to fit only one way. If they do not slip on easily, do not force them. A reversed connector may damage your game and void the warranty.

Ensure the Proper AC Line Frequency. Video games manufactured for operation on 60 Hz line power (i.e., United States) must not be operated in countries with 50 Hz line power (i.e., Europe). The fluorescent light ballast transformer will overheat, causing a potential fire hazard if 60 Hz games are operated on power lines using 50 Hz. Check the product identification label of your game for the line frequency required.

ABOUT NOTES, CAUTIONS, AND WARNINGS

In all Atari publications, notes, cautions, and warnings have the following meaning:

NOTE—A highlighted piece of information.

CAUTION—Equipment and/or parts can be damaged or destroyed if instructions are not followed. You will void the warranty on Atari printed-circuit boards, parts thereon, and video displays if equipment or parts are damaged or destroyed due to failure of following instructions.

WARNING—Players and/or technicians can be injured or killed if instructions are not followed. (The word *WARNING* is always surrounded by international warning symbols—triangles with exclamation marks inside of them.)

Chapter 1

Set-Up

How to Use This Manual

This manual is written for game operators and service technicians, and provides information for setting up, playing, testing, and maintaining your Rolling Thunder* game.

The manual is divided into the following chapters:

- Chapter 1 contains set-up and game play information.
- Chapter 2 contains self-test procedures.
- Chapter 3 contains preventive and corrective maintenance procedures.
- Chapter 4 contains illustrated parts lists.

Schematic diagrams for the Rolling Thunder game circuitry are contained in the *Schematic Package Supplement* (SP-300) included with your game.

This chapter includes information required to set up and play your Rolling Thunder game. Carefully read this information before applying power to the game.

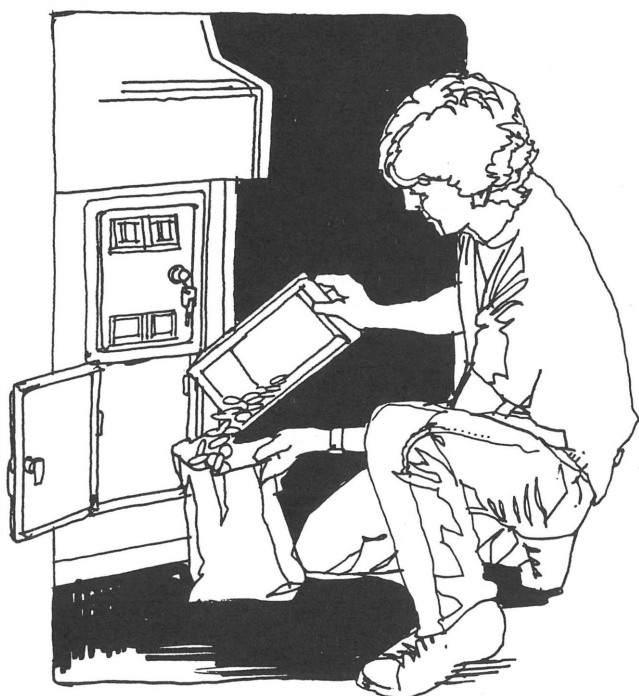

⚠ WARNING ⚠

To avoid electrical shock, do not plug in the cabinet until it has been properly inspected and set up for the line voltage in your area.

This cabinet should only be connected to a grounded three-wire outlet. If you have only a two-wire outlet, we recommend you hire a licensed electrician to install a grounded outlet. Players can receive an electrical shock if the game is not properly grounded.

Do not touch internal parts of the display with your hands or with metal objects.

Inspecting the Game

CAUTION

Do not plug in the game until you have completed the following inspection steps.

Please inspect your Rolling Thunder game carefully to ensure that the game is complete and delivered to you in good condition. Figure 4-1 shows the locations of the component parts of the game. Table 1-1 lists space, power, and environmental requirements.

1. Examine the exterior of the cabinet and the control panel for dents, chips, or broken parts.
2. Use a Phillips screwdriver to remove the screws holding the rear access panel to the cabinet. Unlock and remove the panel. Unlock and open both coin doors. Inspect the interior of the cabinet as follows:
 - a. Ensure that all plug-in connectors (on the cabinet harnesses) are firmly plugged in. Do not force connectors together. The connectors are keyed so they only fit in the proper orientation.
 - b. Ensure that all plug-in integrated circuits on each PCB are firmly plugged into their sockets.
 - c. Inspect the power cord for any cuts or dents in the insulation.
 - d. Inspect the power supply. Make sure that the correct fuses are installed. Check that the harness is plugged in correctly and that the fuse-block cover is mounted in place. Check that the green ground wire is connected.
 - e. Inspect other major subassemblies, such as the video display, printed-circuit boards (PCBs), control, and speaker. Make sure that they are mounted securely and that the green ground wires are connected.

Table 1-1 Game Specifications

Characteristic	Specification
Power Consumption	175 V-A, 125 W RMS maximum
Temperature	+ 5° to + 38° C (+ 37° to + 100° F)
Humidity	Not to exceed 95% relative
Line Voltage	102 to 132 VAC (U.S. games) 198 to 264 VAC (Irish games)
Width	25 ¼ in. (64 cm)
Depth	33 ¼ in. (85 cm)
Height	65 ½ in. (166 cm)
Weight	250 lbs. (113 kg)

- f. Make sure that the game power source and operating environment is within the limits specified in Table 1-1, Game Specifications.

Control and Switch Locations

The following control and switch descriptions are for the Rolling Thunder game. Refer to Figure 1-1 for the locations of the controls and switches.

Power On/Off Switch

The power on/off switch is located at the bottom rear of the cabinet. (See Figure 4-1.)

Volume Control

The volume control is located in the upper right-hand corner of the Game PCB. The PCB is attached to the lower right-side panel of the cabinet. The volume control adjusts the level of sound produced by the game.

Coin Counter

The coin counter is located on the shelf behind the upper coin door. The coin counter records the number of coins deposited.

Self-Test Switch

The self-test switch is located on the End PCB, connected to the front of the Game PCB. Both PCBs are attached to the lower right-side panel of the cabinet. The self-test switch selects the Self-Test Mode to check game operation. Refer to Chapter 2 for a complete description of self-test operation.

Service Switch

The service switch (a two-pin header connection) is located on the End PCB, connected to the front of the Game PCB. Both PCBs are located on the inside lower right-side panel of the cabinet. This switch has two functions, depending on whether the game is in the Self-Test Mode:

1. The switch is used as a coin switch when the game is not in the Self-Test Mode. Squeezing the two connector pins together gives the game one credit.
2. In the Self-Test Mode, the switch is used to make adjustments to the video display. A cross-hatch pattern appears on the display when the switch is turned on. Squeezing the two connector pins together displays the pattern. Squeezing the pins a second time brings back the Self-Test screen. (Refer to the video display service manual included with your game for further information.)

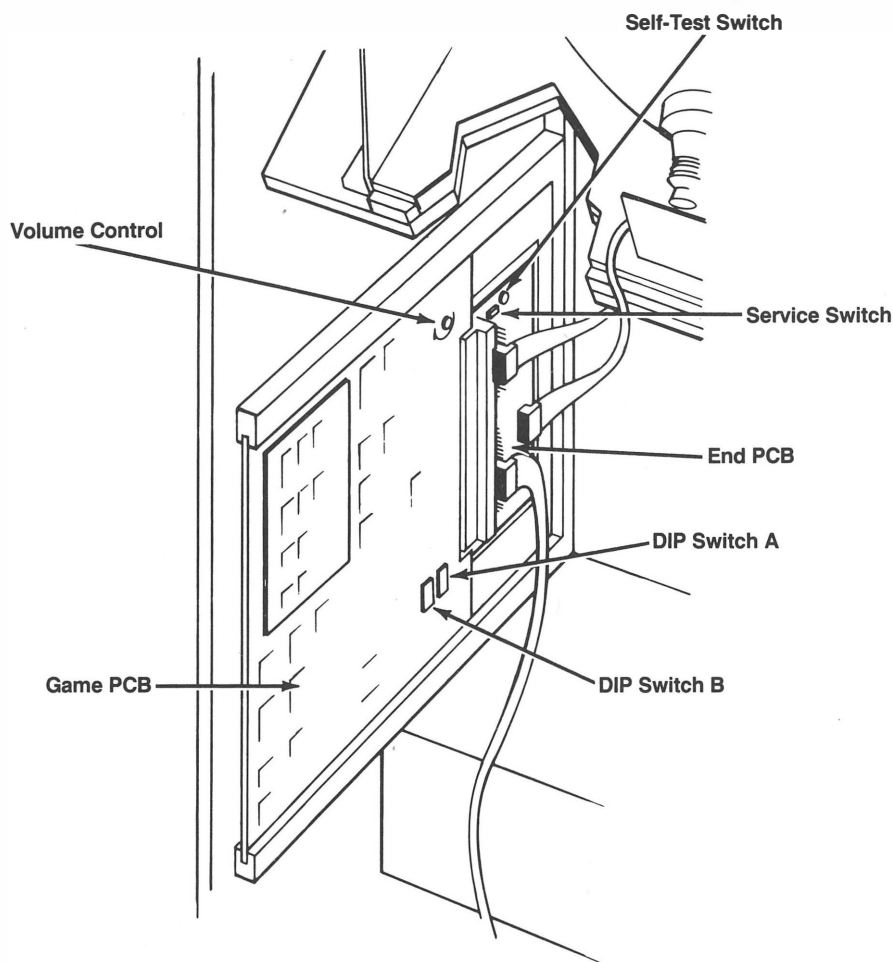

Figure 1-1 Control and Switch Locations

Setting the Coin and Game Option Settings

The Rolling Thunder cabinet has two dual-inline-package (DIP) option switches located on the Game PCB. (See Figure 1-1.)

- Switch A is at location P1/2. Slide switches 2, 3, 7, and 8 on Switch A are for selecting coin options.
- Switch B is at location P2/3. All slide switches except 6 and 7 on Switch B are for selecting game options. (Slide switches 6 and 7 are used to select the cabinet type setting.)

NOTE

Slide switch 5 on Switch A is for factory use only and should always be turned *off*.

Set the coin and credit option settings, and the game option settings by changing the settings of the DIP switches. Refer to Table 1-2 and Table 1-3 for the available options and default (recommended) settings.

To change the coin and credit settings, and the game settings, use a pen or a sharp-pointed instrument to slide the appropriate small buttons to different settings. Right is the *on position*, and left is the *off position*. The joystick control and the push buttons are *not* used to change these settings.

Refer to Chapter 2, Self-Test, for a more detailed description and explanation of the option settings.

Game Play

This section of the manual describes the theme of the Rolling Thunder game, the operating modes, and the game play features.

Introduction

Rolling Thunder is a one- or two-player (alternating) game where the player controls the hero whose code name is Albatross. The story takes place in 1960 in New York City where the elusive Maboo, leader of the secret society Geldra, is plotting to conquer the world.

Rolling Thunder is the undercover arm of a secret police organization. Their female agent, Leila, was sent on special assignment into Geldra's underground headquarters. Her mission was to expose the treacherous conspiracy, but she was captured.

Agent Albatross is the only man on the Rolling Thunder force who can possibly save Leila and complete the mission.

Operating Modes

Rolling Thunder has four operating modes: Attract, Play, High Score, and Self-Test.

Game Play

Game play starts with the player at the base of the enemy headquarters. Using a four-position joystick and Jump and Shoot buttons, the player makes way to the end of each area by evading or destroying enemy guards. The screen scrolls horizontally along with player maneuvers. By using the Shoot button, the player activates his weapon. Limited ammunition is given to the player at the start of each area, and he must collect additional ammunition by entering doors marked Bullets. If the player enters a door marked Arms, he receives a more powerful machine gun. By using the Jump button, the player can strategically evade or set up enemy attacks.

The game playfields consist of various areas including old buildings, warehouses, and caves. To complete each area, the player must reach the exit. However, a timer and a life gauge limit the player in each area. Upon successful completion of each area, the screen briefly changes to show Maboo at his control station, as he awaits Albatross about to penetrate his headquarters.

As the game progresses, the player is awarded bonus lives at several score thresholds.

Table 1-2 DIP Switch A Option Settings

Settings of Switch A on Rolling Thunder Game PCB (at P1/2)								Option
1	2	3	4	5	6	7	8	
								Coins Per Credit (Right Mechanism)
						Off	Off	1 Coin 1 Credit ◀
						Off	On	1 Coin 2 Credits
						On	Off	1 Coin 5 Credits *
						On	On	1 Coin 6 Credits
								Screen Hold
							Off	Normal ◀
							On	Hold
								For Factory Use Only
						Off		Always in <i>Off</i> Position ◀
						On		Never in <i>On</i> Position
								Attract Sound
							Off	Sound ◀
							On	No Sound
								Coins Per Credit (Left Mechanism)
	Off	Off						1 Coin 1 Credit ◀
	Off	On						1 Coin 3 Credits ◀
	On	Off						2 Coins 1 Credit
	On	On						3 Coins 1 Credit
								Self-Test
								Normal (Attract Mode) ◀
								Self-Test Mode

Table 1-3 DIP Switch B Option Settings

Settings of Switch B on Rolling Thunder Game PCB (at P2/3)								Option
1	2	3	4	5	6	7	8	
								Game Continuation
							Off	6 Games Maximum ◀
							On	3 Games Maximum
								Cabinet Type
						Off	Off	Type A (Upright) ◀
						Off	On	Type B (Cocktail—no flip)
						On	On	Type C (Cocktail—flip)
								Select Level
							Off	No
							On	Yes ◀
								Game Difficulty
							Off	Normal ◀
							On	Easy
								Timer Value
							Off	120 Seconds ◀
							On	150 Seconds
								Bonus Lives Granted at:
							Off	70,000 Points and 200,000 Points ◀
							On	100,000 Points and 300,000 Points
								Number of Starting Lives
							Off	3 ◀
							On	5

◀ *Manufacturer's recommended settings*
 * Recommended settings for Germany
 ◀ Recommended settings for United Kingdom

N O T E S

Chapter 2

Self-Test

The Rolling Thunder* game tests itself and provides visual and audible indications of the condition of the game circuitry. Self-test information is visually displayed on the screen and audibly presented through the sound system. No additional equipment is required.

We suggest that you perform a self-test when you first set up the game, each time you collect the money, or when you suspect game failure. Coin and game options are selected in the Self-Test Mode.

When the self-test switch is turned on, the game enters the Self-Test Mode. Turning the self-test switch off at any time during the Self-Test Mode causes the game to return to the Attract Mode.

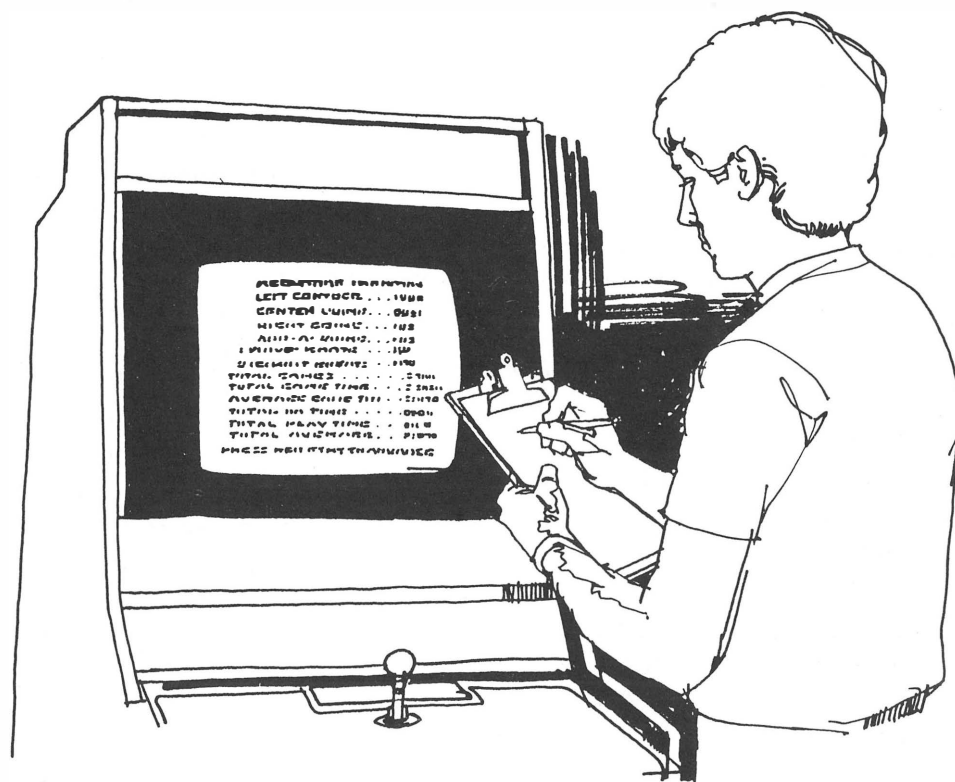

*Rolling Thunder is engineered and designed by Namco Ltd.
Manufactured by Atari Games. Trademark and © Namco 1986.

Self-Test Screen

The Self-Test screen displays the game Main and Sub ROM condition, coin and credit options, game options, dual-inline-package (DIP) switch settings, and other game conditions. After turning on the self-test switch, the Self-Test screen shown in Figure 2-1 is displayed. The self-test switch is located on the End Printed-Circuit Board (PCB), connected to the front of the Game PCB. Both PCBs are attached to the inside lower right-side panel of the cabinet. (See Figure 1-1.)

DIP Switch Settings

The Rolling Thunder game has two DIP option switches located on the Game PCB. (See Figure 1-1.) The DIP Switch settings indicate the current settings of both DIP Switch A and DIP Switch B.

- Switch A is at location P1/2. Slide switches 2, 3, 7, and 8 on Switch A are for selecting coin options.
- Switch B is at location P2/3. All slide switches except 6 and 7 on Switch B are for selecting game options. (Slide switches 6 and 7 are used to select the cabinet type setting.)

NOTE

Slide switch 5 on Switch A is for factory use only and should always be turned *off*.

One row of numbers refers to switches 1 through 8 on Switch A; the second row of numbers refers to switches 1 through 8 on Switch B. *1* denotes that the switch is turned on; *0* denotes that it is turned off. The settings are displayed on the screen as:

MAIN ROM	OK	SUB ROM	OK
RAM	OK	CUSTOM	OK
COIN1 1 COIN	1 CREDIT		
COIN2 1 COIN	1 CREDIT		
ATTRACT	SOUND		
ALBATROSS	3		
BONUS	70000/200000	PTS	
TIMER	120	SEC	
DIFFICULTY	NORMAL		
CABINET	TYPE A		
CONTINUATION	6	SELECT	YES
SOUND PSG	0		
DIP SW A	10000000		
DIP SW B	00000000		

Figure 2-1 Self-Test Screen

DIP SW A 1 0 0 0 0 0 0 0

DIP SW B 0 0 0 0 0 0 0 0

Set the coin and credit option settings, and the game option settings by changing the settings of the DIP switches. Refer to Table 2-1 and Table 2-2 for the available options and default (recommended) settings.

To change the coin and credit settings, and the game settings, use a pen or a sharp-pointed instrument to slide the appropriate small buttons to different settings. Right is the *on position*, and left is the *off position*. The joystick control and the push buttons are *not* used to change these settings.

Main ROM/Sub ROM Test

The Main ROM/Sub ROM Test indicates the condition of the game Main ROM and the Sub ROM circuitry, and is displayed on the screen as:

MAINROM OK SUBROM OK

This message indicates that both the Main ROM and the Sub ROM are normal. If either ROM fails, the message *BAD*, and not *OK*, is displayed. *MAINROM* refers to ROM on the Game PCB. *SUB ROM* refers to ROM on the Sub PCB, or the “piggyback” PCB.

RAM/Custom IC Test

The RAM/Custom IC Test indicates the condition of the game RAM and the custom integrated circuits (ICs), and is displayed on the screen as:

RAM OK CUSTOM OK

This message indicates that both the RAM and the custom ICs are normal. If either the RAM or any of the custom ICs fail, the message *BAD* is displayed.

Coin and Credit Options

The current coin and credit option settings are displayed on the screen as:

COIN1 1 COIN 1 CREDIT

COIN2 1 COIN 1 CREDIT

These are the default (recommended) settings for coin mechanisms 1 (left) and 2 (right).

The coin and credit options can be changed by resetting the DIP switches located on the Game PCB. The *COIN1* setting can be changed by resetting slide switches 2 and 3 on Switch A to the *On* position. The *COIN2* setting can be changed by resetting slide switches 7 and 8 on Switch A to the *On* position. (Refer to *DIP Switch Settings* earlier in this chapter for more information.)

Attract Mode Sound Setting

The Attract Mode Sound setting indicates that sound is selected when the game is in the attract mode. This setting is displayed on the screen as:

ATTRACT SOUND

The sound can be turned off in the attract mode by re-setting slide switch 4 on DIP Switch A to the *On* position.

Starting Lives Setting

The Starting Lives setting indicates the number of lives granted when game play begins, and is displayed on the screen as:

ALBATROSS 3

3 lives is the default (recommended) setting. The setting can be changed to 5 lives by resetting slide switch 1 on DIP Switch B to the *On* setting. Note that in the game play mode, the screen displays the words *MAN x* for the remaining number of men (lives).

Bonus Lives Setting

The Bonus Lives setting indicates when bonus lives are granted, and is displayed on the screen as:

BONUS 70,000/200,000 PTS

70,000 and 200,000 points is the default (recommended) setting for bonus lives. The setting can be changed to 100,000 and 300,000 points by resetting slide switch 2 on DIP Switch B to the *On* position.

Timer Value Setting

The Timer Value setting indicates the amount of game play time in seconds, and is displayed on the screen as:

TIMER 120 SEC

120 seconds is the default (recommended) setting. The setting can be changed to 150 seconds by resetting slide switch 3 on DIP Switch B to the *On* position.

Game Difficulty Setting

The Game Difficulty setting indicates the difficulty level of the game, and is displayed on the screen as:

DIFFICULTY NORMAL

Normal is the default (recommended) setting. The setting can be changed to the easy level by resetting slide switch 4 on DIP switch B to the *On* position.

Cabinet Type Setting

The Cabinet Type setting indicates whether the screen should alternately flip 180 degrees between two players. This setting is displayed on the screen as:

CABINET TYPE A

Leave slide switches 6 and 7 on DIP Switch B at the *Off* setting.

Game Continuation Setting

The Game Continuation setting indicates the maximum number of credits allowed for game continuation. This setting is displayed on the screen as:

CONTINUATION 6

6 credits maximum is the default (recommended) setting. The setting can be changed to 3 credits maximum by re-setting slide switch 8 on DIP Switch B to the *On* position.

Select Level Setting

The Select Level Setting indicates whether or not the Select Level function is activated. This setting is displayed on the screen as:

SELECT YES

If set to *Yes*, players can choose a starting level from Areas 1 through 5. (The player selects the starting level by holding down the 1-player start button, and moving the joystick to select any of the first five areas or levels.) If set to *No*, the game automatically starts at Story 1, Area 1.

Sound Test

The Sound Test indicates the condition of the sound-effects circuitry (when sound is selected in the Attract Mode setting). This test is displayed on the screen as:

SOUND PSG 0

Different sound numbers can be selected. The number is selected by moving the joystick to the right (increments the number) or to the left (decrements the number). Moving the joystick front (toward the display screen) or back selects *PSG*, *FM*, or *VOICE*. *PSG* indicates sound effect, and *FM* indicates music.

Service Switch

The service switch (a two-pin header connector) is located on the End PCB, connected to the front of the Game PCB. Both PCBs are located on the inside lower right-side panel of the cabinet. This switch has two functions, depending on whether the game is in the Self-Test Mode:

1. The switch is used as a coin switch when the game is not in the Self-Test Mode. Squeezing the two connector pins together gives the game one credit.
2. In the Self-Test Mode, the switch is used to make adjustments to the video display. A cross-hatch pattern appears on the display when the switch is turned on. Squeezing the two connector pins together displays the pattern. Squeezing the pins a second time brings back the Self-Test screen. (Refer to the video display service manual included with your game for further information.)

Table 2-1 DIP Switch A Option Settings

Settings of Switch A on Rolling Thunder Game PCB (at P1/2)								Option
1	2	3	4	5	6	7	8	
						Off	Off	Coins Per Credit (Right Mechanism)
						Off	On	1 Coin 1 Credit ◀
						On	Off	1 Coin 2 Credits
						On	On	1 Coin 5 Credits *
								1 Coin 6 Credits
								Screen Hold
						Off		Normal ◀
						On		Hold
								For Factory Use Only
						Off		Always in <i>Off</i> Position ◀
						On		Never in <i>On</i> Position
								Attract Sound
						Off		Sound ◀
						On		No Sound
								Coins Per Credit (Left Mechanism)
	Off	Off						1 Coin 1 Credit ◀
	Off	On						1 Coin 3 Credits ▣
	On	Off						2 Coins 1 Credit
	On	On						3 Coins 1 Credit
								Self-Test
Off								Normal (Attract Mode) ◀
On								Self-Test Mode

Table 2-2 DIP Switch B Option Settings

Settings of Switch B on Rolling Thunder Game PCB (at P2/3)								Option
1	2	3	4	5	6	7	8	
							Off	Game Continuation
							On	6 Games Maximum ◀
								3 Games Maximum
						Off	Off	Cabinet Type
						Off	On	Type A (Upright) ◀
						On	On	Type B (Cocktail—no flip)
								Type C (Cocktail—flip)
								Select Level
						Off		No
						On		Yes ◀
								Game Difficulty
						Off		Normal ◀
						On		Easy
								Timer Value
						Off		120 Seconds ◀
						On		150 Seconds
								Bonus Lives Granted at:
	Off							70,000 Points and 200,000 Points ◀
	On							100,000 Points and 300,000 Points
								Number of Starting Lives
Off								3 ◀
On								5

◀ *Manufacturer's recommended settings*

* Recommended settings for Germany

▣ Recommended settings for United Kingdom

Maintenance

This chapter includes preventive and corrective maintenance procedures for the Rolling Thunder game components that are subject to the most use. To assure maximum trouble-free operation from this game, we recommend that preventive maintenance be performed as described in this chapter.

Removal and replacement procedures are provided for components that might require corrective maintenance. Chapter 4, Illustrated Parts Lists, can also be used to locate the parts of this game that are mentioned, but not illustrated, in the maintenance procedures.

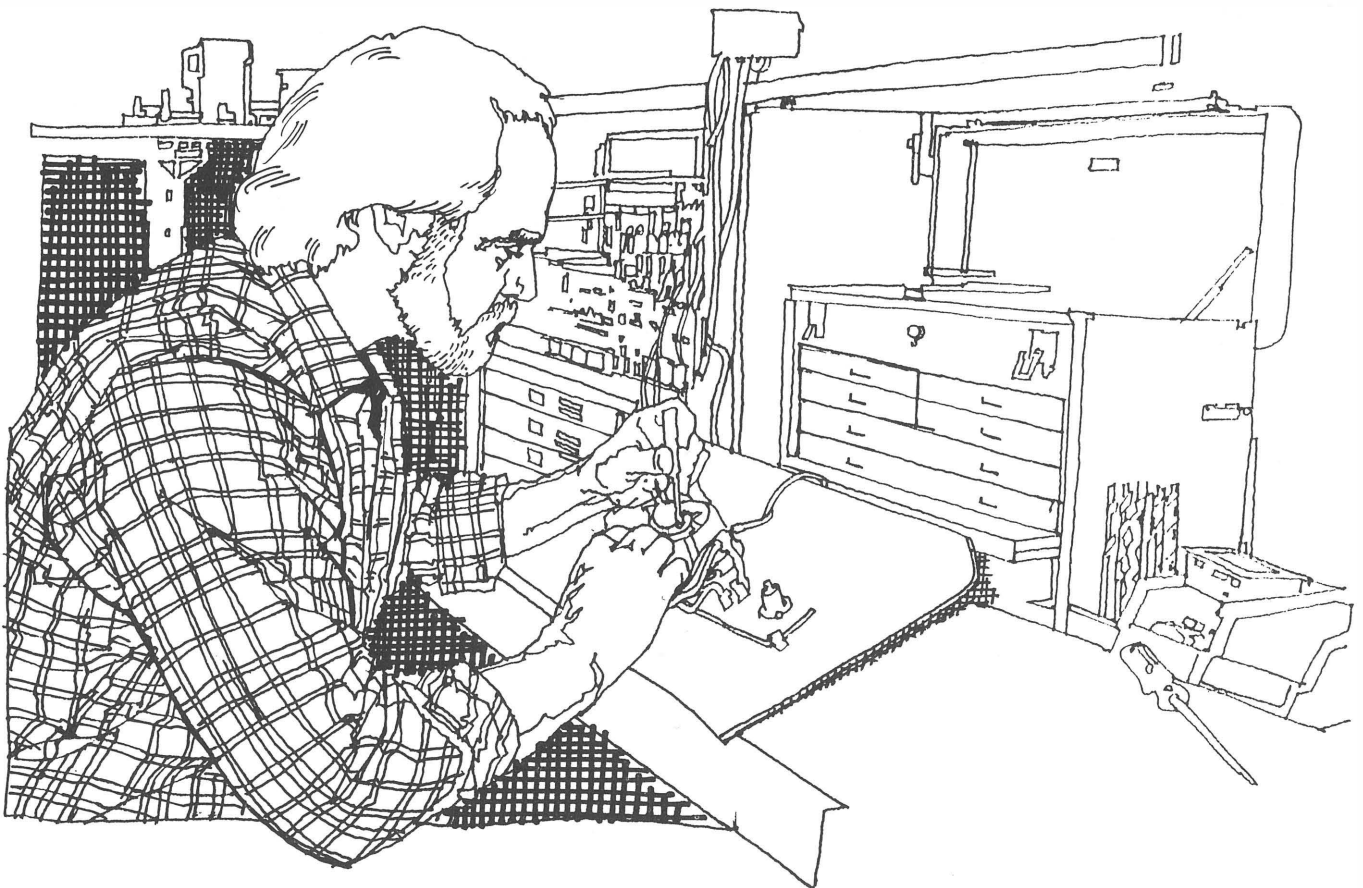

Preventive Maintenance

Preventive maintenance includes cleaning, lubricating, and tightening hardware. How often preventive maintenance is performed depends upon the game environment and frequency of play. However, for those components listed in Table 3-1 Preventive-Maintenance Intervals, we recommend that preventive maintenance be performed at the intervals specified.

Preventive-Maintenance Intervals

The preventive-maintenance intervals specified in Table 3-1 are the recommended minimum requirements for the components listed.

⚠ WARNING ⚠

To avoid possible electrical shock, turn off the game before performing any maintenance procedures.

Removing the Control Panel

Perform the following procedure to remove/replace the control panel. (See Figure 3-3.)

1. Unlock and open the upper coin door.
2. Carefully reach up through the upper coin door opening and release the two spring draw latches located under the control panel on each side of the cabinet.
3. Grasp the control panel on the top edge (next to the speaker grille) and gently tilt the panel up slightly. Remove the panel from the front edge of the cabinet. Stand the control panel on its back edge by placing it in the wood slots located under the control panel on each side of the cabinet. The panel is now in position for servicing the leaf switches or the joystick control.
4. If you need to remove the control panel, disconnect the control harness connector from the Game PCB and disconnect the green ground wire.

Table 3-1 Recommended Preventive-Maintenance Intervals

Joystick Control	Lubricate and tighten hardware at least every three months.
Coin Mechanism	Inspect whenever you collect coins. Clean at least every three months.

5. Carefully lift the control panel from the cabinet.
6. Replace the control panel in the reverse order of removal.

Cleaning the Push-Button Leaf Switches

Perform the following procedure to clean the push-button leaf switch contacts and tighten the securing hardware. (See Figure 3-1.)

1. Follow the procedure described in steps 1–3 above for removing the control panel.
2. Use electrical contact cleaner to clean the contacts. Do not burnish them. When the push button is pressed, the wiping action of the cross-bar contacts provides a self-cleaning feature.
3. Using a 1⁵/₁₆-inch open-end wrench, tighten the stamped nut securing the push-button leaf switch to the control panel.

Cleaning the Coin Mechanism

Use a soft-bristled brush to remove loose dust or foreign material from the coin mechanism. A toothbrush can be used to remove any stubborn build-up of residue in the coin path. After cleaning the coin mechanism, blow out all of the dust with compressed air.

Cleaning the Interior Components

Perform the following procedure to clean the components inside the cabinet.

⚠ WARNING ⚠

Turn off the game power, but do not unplug the power cord before cleaning inside the cabinet. The power cord provides a ground path for stray static voltages that might be present on the cleaning tools.

1. Unlock and remove the rear access panel.
2. Use a vacuum cleaner with a soft long-bristled brush attachment or a soft-bristled paint brush to remove loose dirt and dust accumulated on the inside of the cabinet. Be sure to clean the electrical components thoroughly (power supplies, PCB assemblies, display, etc.).

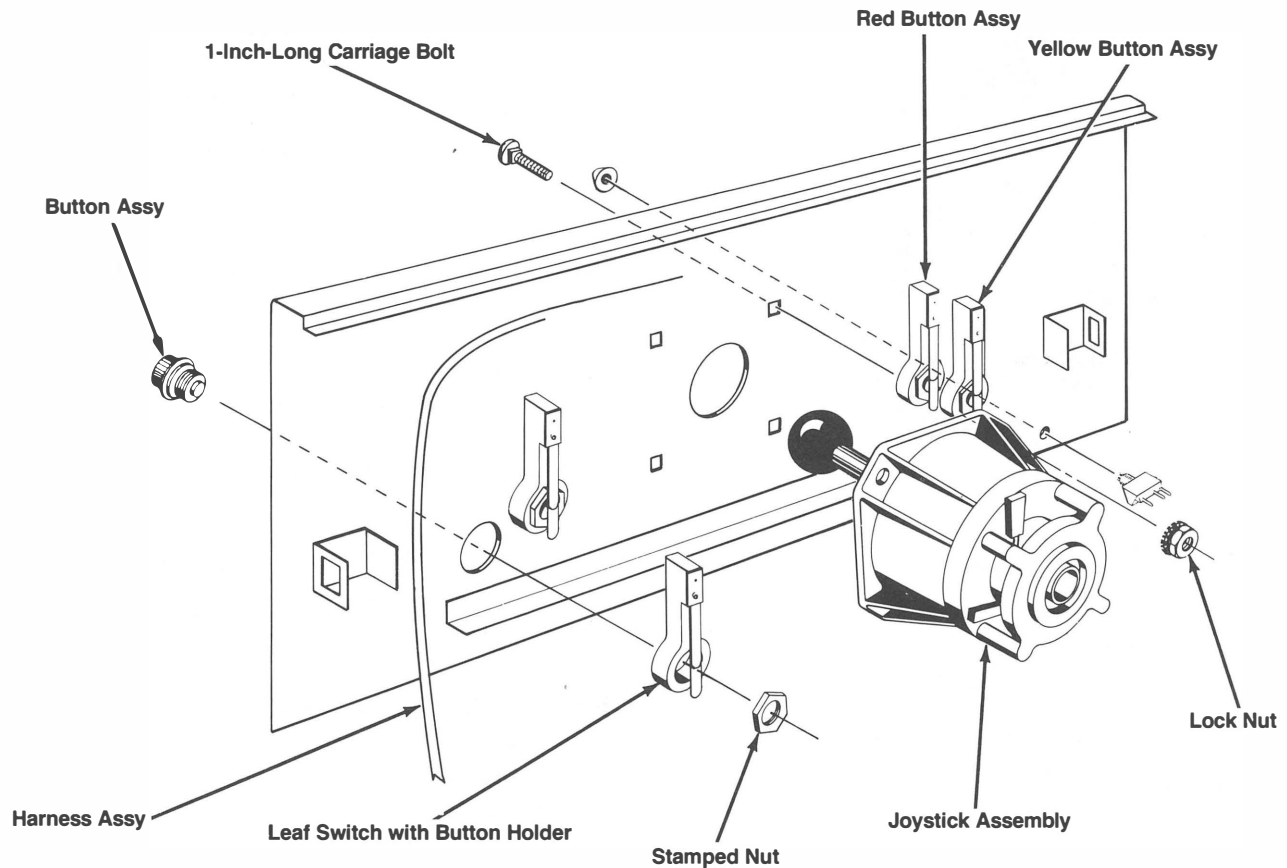

Figure 3-1 Leaf Switch and Joystick Removal

CAUTION

Be extremely careful when cleaning the electrical components inside the cabinet. Avoid touching the electrical components with any solid object other than the soft bristles of the vacuum attachment or paint brush.

Joystick Control

Preventive maintenance on the joystick control consists of inspecting the pivot and actuator balls for excessive wear or dirt, lubricating the pivot ball, adjusting the leaf

switches and, if necessary, replacing or tightening the securing hardware.

Lubricating the Joystick Control

Perform the following procedure to lubricate and tighten the joystick control. (See Figure 3-2.)

1. Remove the control panel as previously described.
2. Apply a light film of Lithium grease (Atari part no. 107027-001) to the lubrication points shown in Figure 3-2.
3. Using a $\frac{3}{8}$ -inch wrench, tighten the four nuts holding the joystick to the control panel.
4. Using a $\frac{1}{4}$ -inch wrench (or an appropriate tool), tighten the four screws holding the positioning plate to the lower housing.

Corrective Maintenance

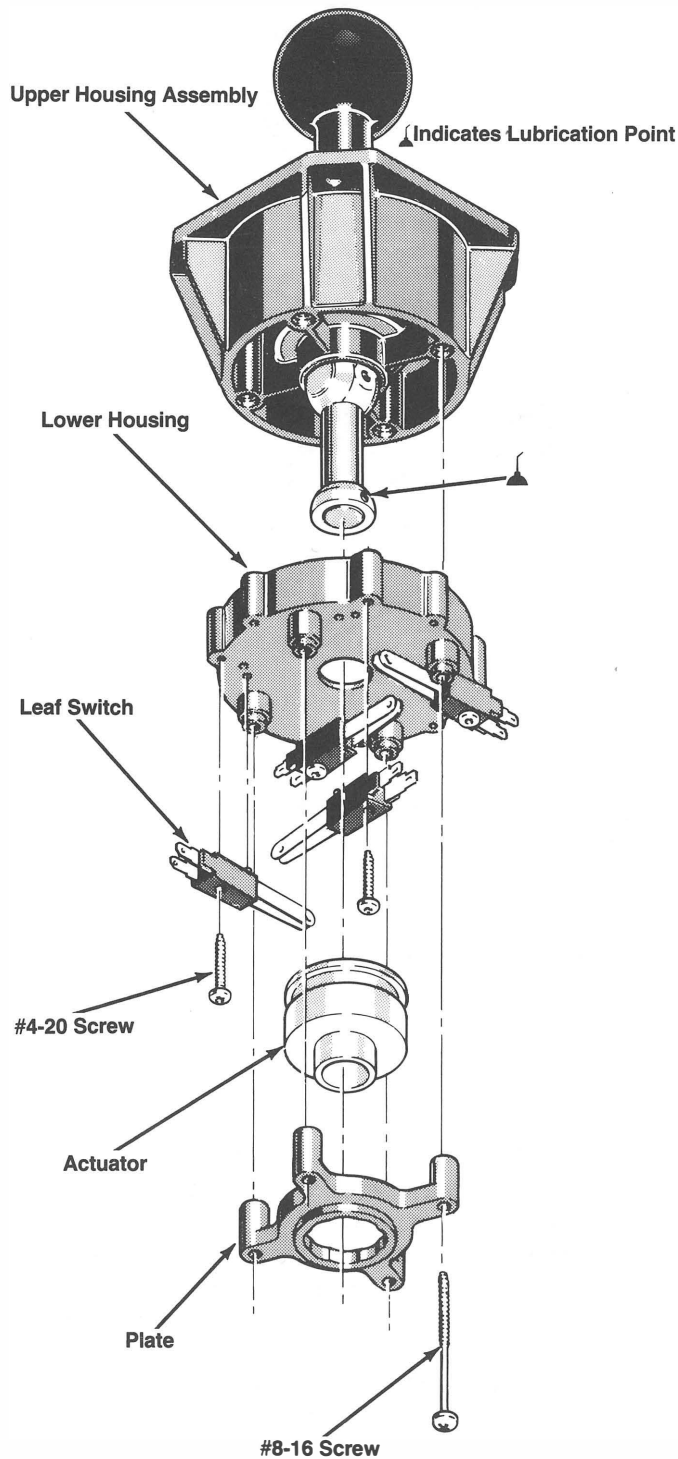

Figure 3-2 Joystick Lubrication

Corrective maintenance consists of removing, disassembling, reassembling, and replacing the push-button leaf switches, joystick control, game printed circuit board (PCB), video display, and speaker. The procedures for removing and replacing the Game PCB, video display, and the speaker follow.

Removing the Game PCB

Perform the following procedure to remove/replace the Game PCB.

1. Turn the game power off.
2. Remove the rear access panel of the cabinet.
3. Remove the mounting screw and the fiber washer from the upper right-hand corner of the Game PCB.
4. Grasp the back edge of the Game PCB and gently slide it straight backwards until it just clears the rear slotted guide.
5. Replace the Game PCB in the reverse order of removal.

Removing the Video Display

Perform the following procedure to remove/replace the video display. (See Figure 3-3.)

1. Turn the game power off and wait two minutes. Unplug the power cord.
2. Remove the control panel as described under *Preventive Maintenance*.
3. Using a Phillips screwdriver, remove the four screws holding the speaker grille to the cabinet.
4. Remove the video display shield.
5. Remove the bezel.
6. Using a Phillips screwdriver, remove the four screws holding the rear access panel to the cabinet.

⚠ WARNING ⚠

High Voltage

The video display contains lethal high voltages. To avoid injury, do not attempt to service this display until you observe all precautions necessary for working on high-voltage equipment.

X-Radiation

The video display has been designed to minimize X-radiation. However, to avoid possible exposure to soft X-radiation, **never** modify the high-voltage circuitry.

Implosion Hazard

The cathode-ray tube may implode if struck or dropped. Shattered glass may cause injury within a 6-foot radius. Use care when handling the display.

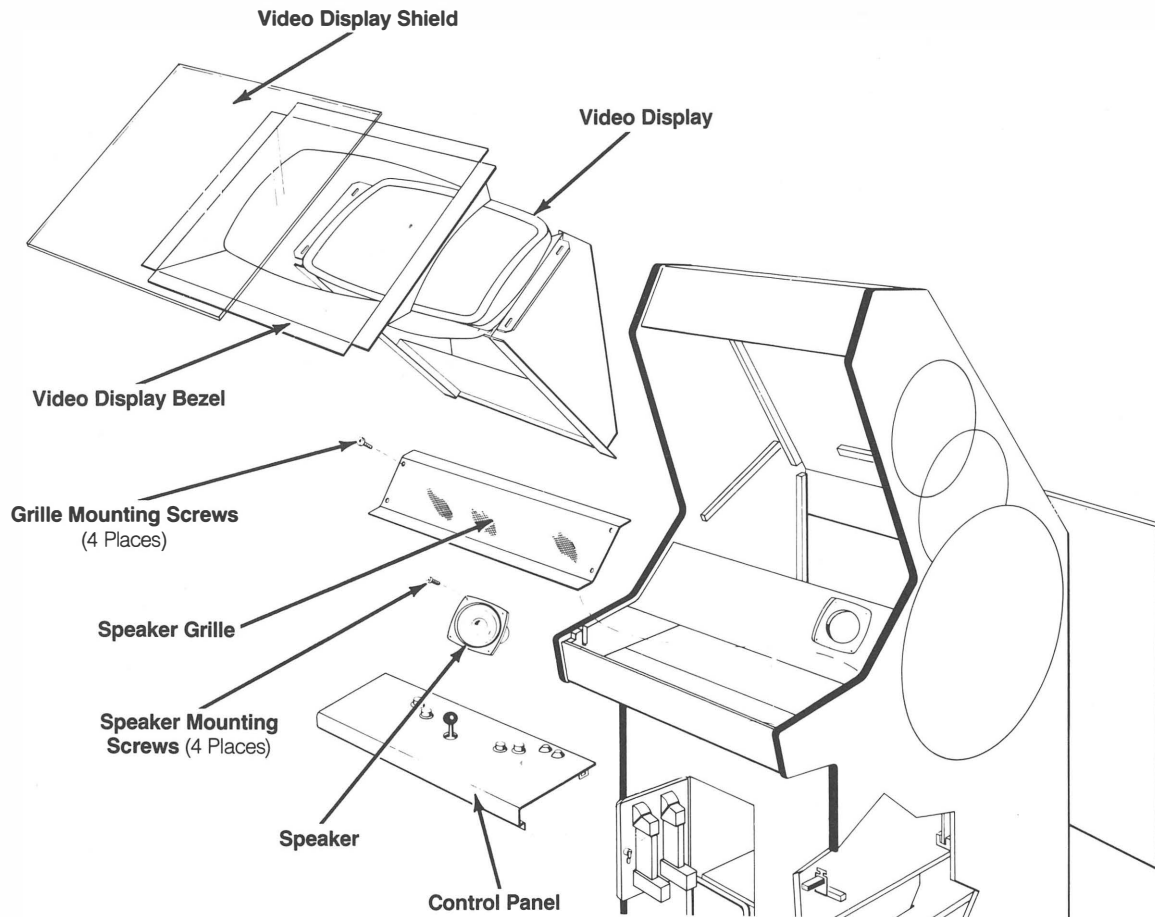

Figure 3-3 Control Panel, Video Display, and Speaker Removal

7. Discharge the high voltage from the cathode-ray tube (CRT) before proceeding. The display assembly contains a circuit for discharging the high voltage to ground when power is removed. However, to make certain, always discharge the display as follows.
 - a. Attach one end of a large, well-insulated, 18-gauge jumper wire to ground.
 - b. Momentarily touch the free end of the grounded jumper to the CRT anode by sliding it under the anode cap.
 - c. Wait two minutes and repeat part b.
8. From the back of the cabinet, unplug the display harness connectors from the display.



WARNING



To avoid dropping the video display, use extreme care when removing the display from the cabinet. We recommend that a second person *carefully* hold the display chassis from the back of the cabinet while the other person lifts it from the front of the cabinet.

9. Using a $\frac{7}{16}$ -inch wrench, reach through the control panel opening and remove the four nuts and washers holding the video display to the cabinet shelf.
10. Push the four carriage bolts up from the bottom of the shelf and remove them from the back of the cabinet.
11. Carefully slide the display out through the front of the cabinet.
12. Replace the video display as described in the following procedure.

NOTE

Whenever the cathode-ray tube and yoke are replaced as a single unit, readjust the brightness, size, and centering as described in the display manual. Check the purity and convergence also according to the display manual instructions, but adjust both *only if required*.

Replacing the Video Display

Perform the following procedure to replace the video display in the cabinet. (See Figure 3-3.)

1. Gently lift the video display through the front of the cabinet and onto the shelf.
2. Position the display so that the four slots in the chassis are aligned with the corresponding mounting holes in the cabinet shelf.
3. From the back of the cabinet, insert the four carriage bolts into the four slots in the chassis and through the mounting holes in the shelf.
4. From the back of the cabinet, slide the display back until the rear of the CRT frame fits against the wood cleat at the rear of the shelf.
5. From the back of the cabinet, push the four carriage bolts through the CRT frame and shelf. Through the control panel opening, tighten the four mounting nuts and washers under the shelf using a $\frac{7}{16}$ -inch wrench.

6. Connect the display harness to the display PCB.
7. Replace the bezel.
8. Replace the video display shield.
9. Using a Phillips screwdriver, securely tighten the four screws holding the speaker grille to the cabinet.

Removing the Speaker

Perform the following procedure to remove/replace the speaker. (See Figure 3-3.)

1. Using a Phillips screwdriver, remove the four screws on the front of the speaker grille.
2. Lift the speaker grille from the cabinet.

CAUTION

Do not touch the speaker cone when handling the speaker. The cone material is fragile and can be easily damaged.

3. Using a Phillips screwdriver, remove the four screws holding the speaker to the cabinet.
4. Remove the speaker just far enough to disconnect the two speaker wires.
5. With the tabs pointed outward, replace the speaker in the reverse order of removal.

Illustrated Parts Lists

This chapter provides information you need to order parts for your game. Common hardware (screws, nuts, washers, etc.) has been deleted from most of the parts lists.

The PCB parts lists are arranged in alphabetical order by component. Each component subsection is arranged alphanumerically by reference designator.

Other parts lists are arranged alphanumerically by Atari part number. In these parts lists, all A-prefix numbers come first. Following these are numbers in sequence evaluated up to the hyphen, namely 00- through 99-, then 000598- through approximately 201000-.

When ordering parts, please give the part number, part name, number of this manual, and serial number of your game. This will help us fill your order rapidly and correctly. We hope the results will be less downtime and more profit from your game.

Atari Customer Service numbers are listed on the inside front cover of this manual.

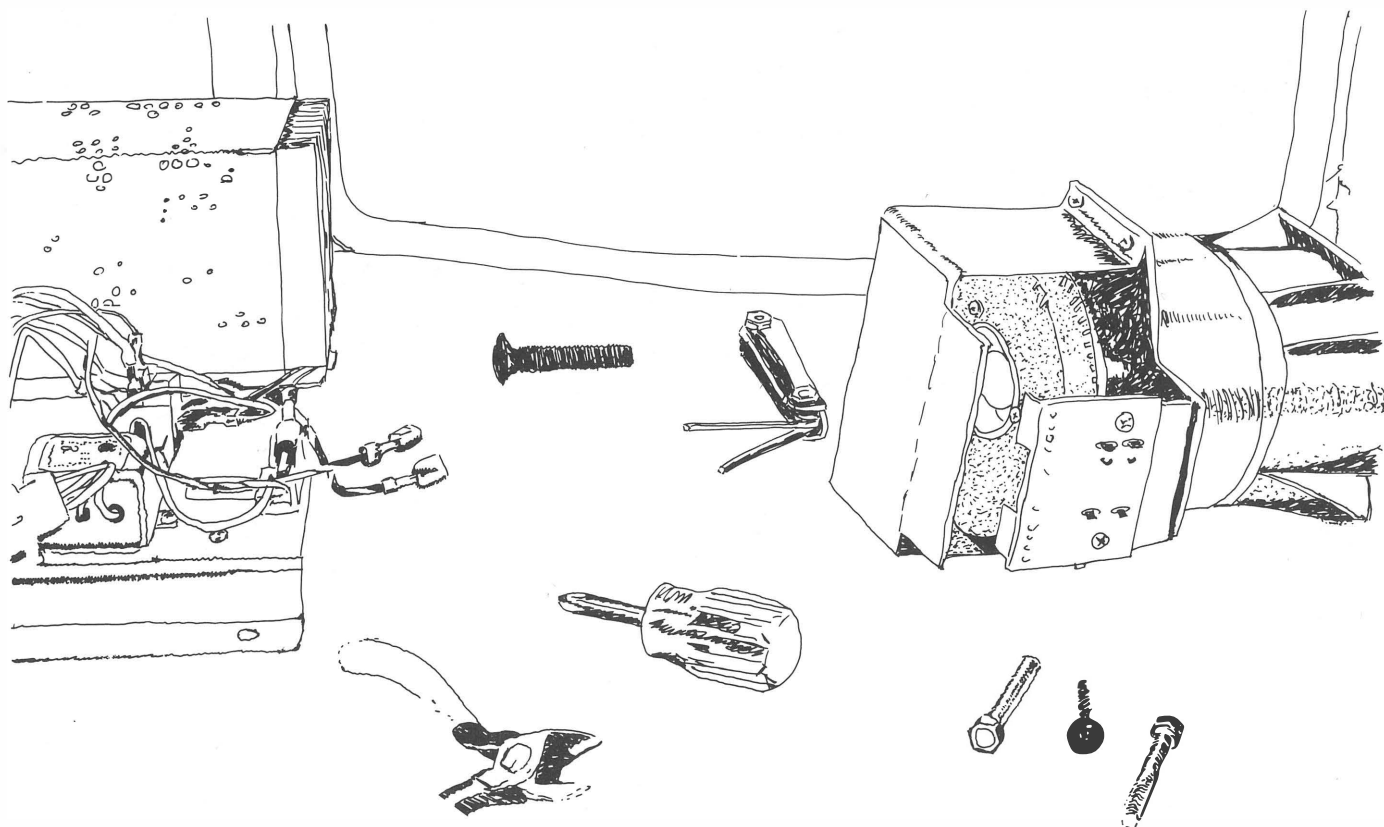

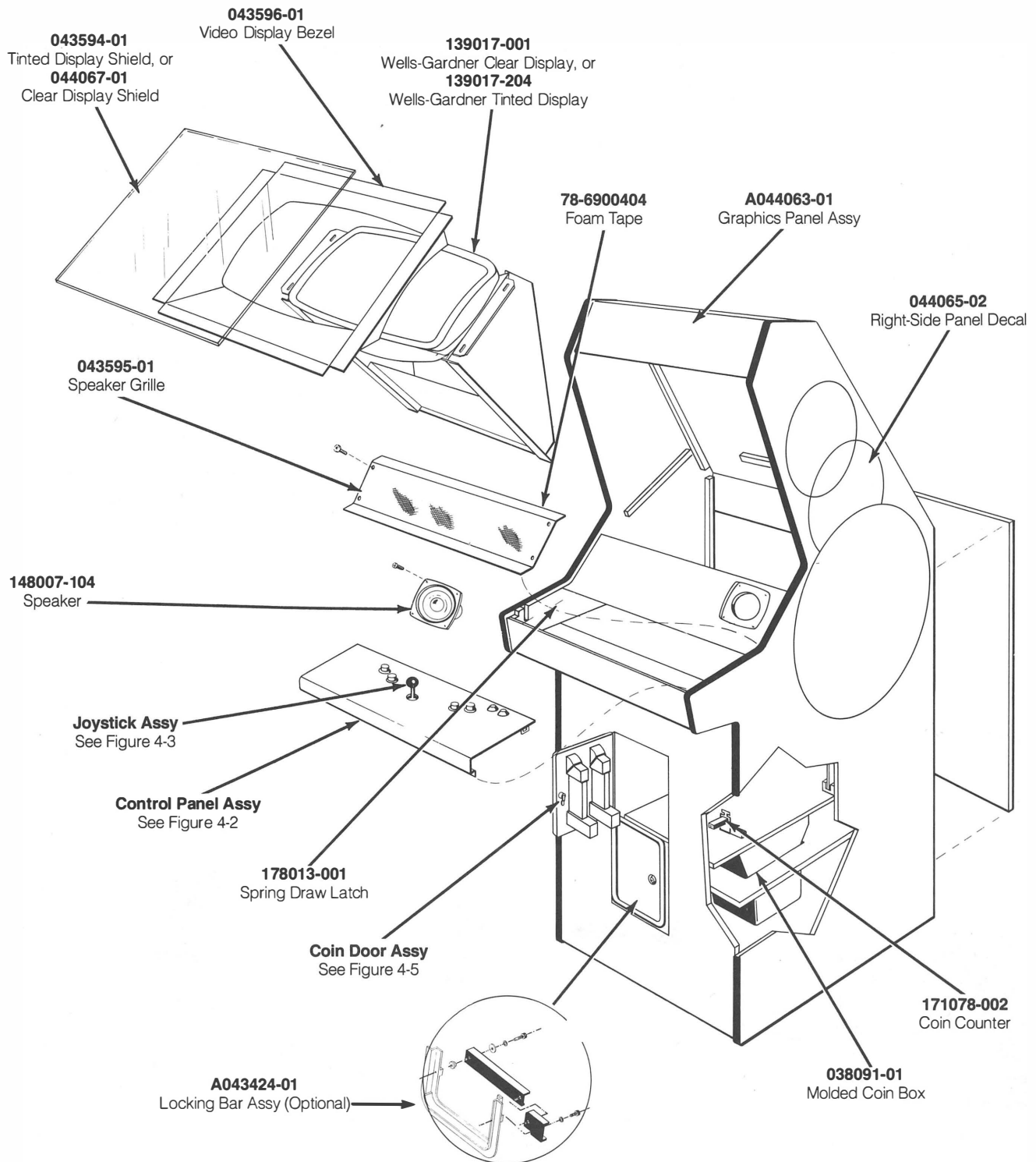

**Figure 4-1 Cabinet-Mounted Assemblies
A044060-01 A**

NOTE

To comply with emission requirements, the Federal Communications Commission requires that the ground strap be secured to both the Game PCB and End PCB Assemblies. *Do not operate this game* without properly installing the ground strap.

Items Not Shown

A044083-01
Speaker Harness Assy

034536-02
Vibration Damper

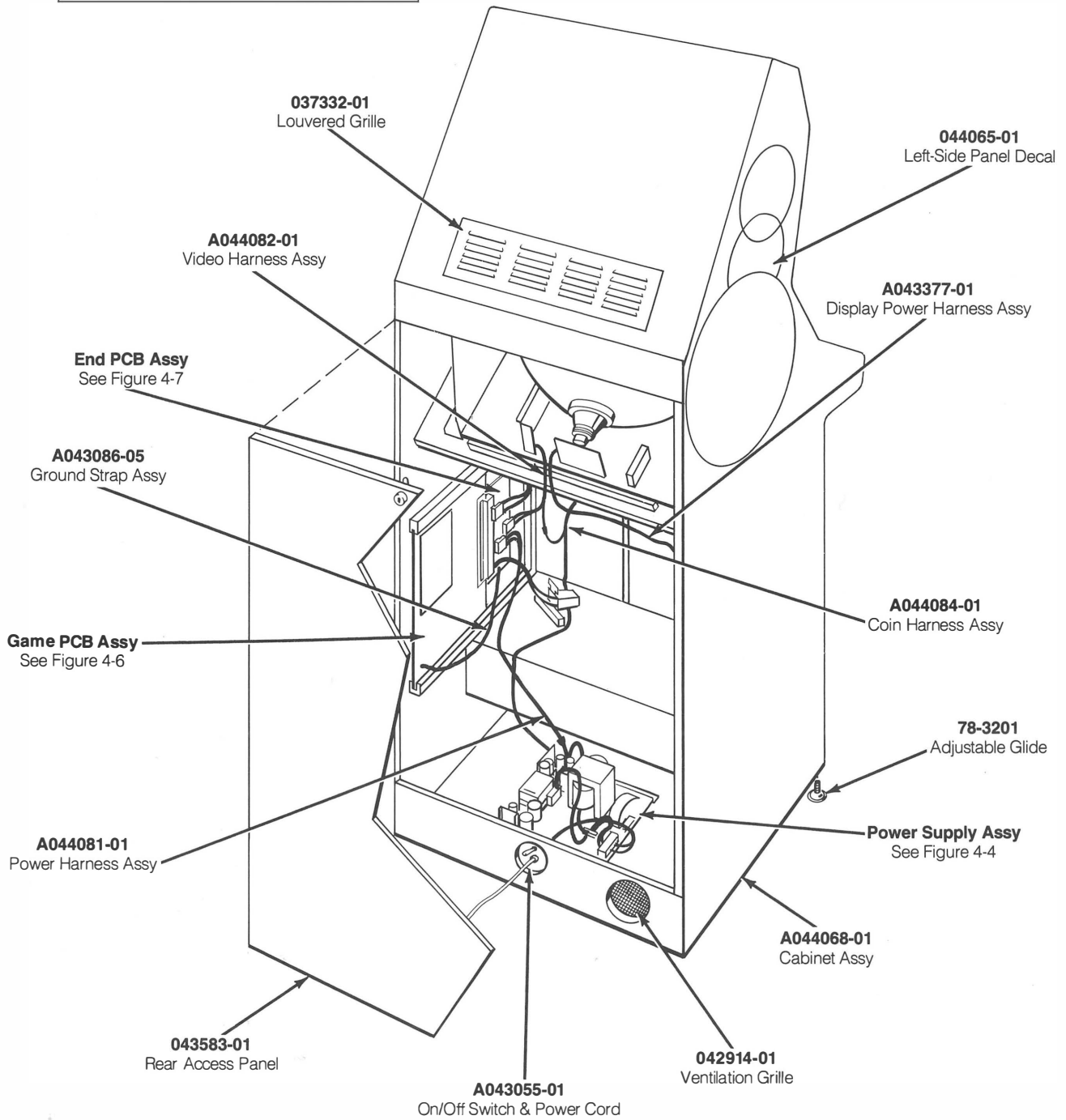
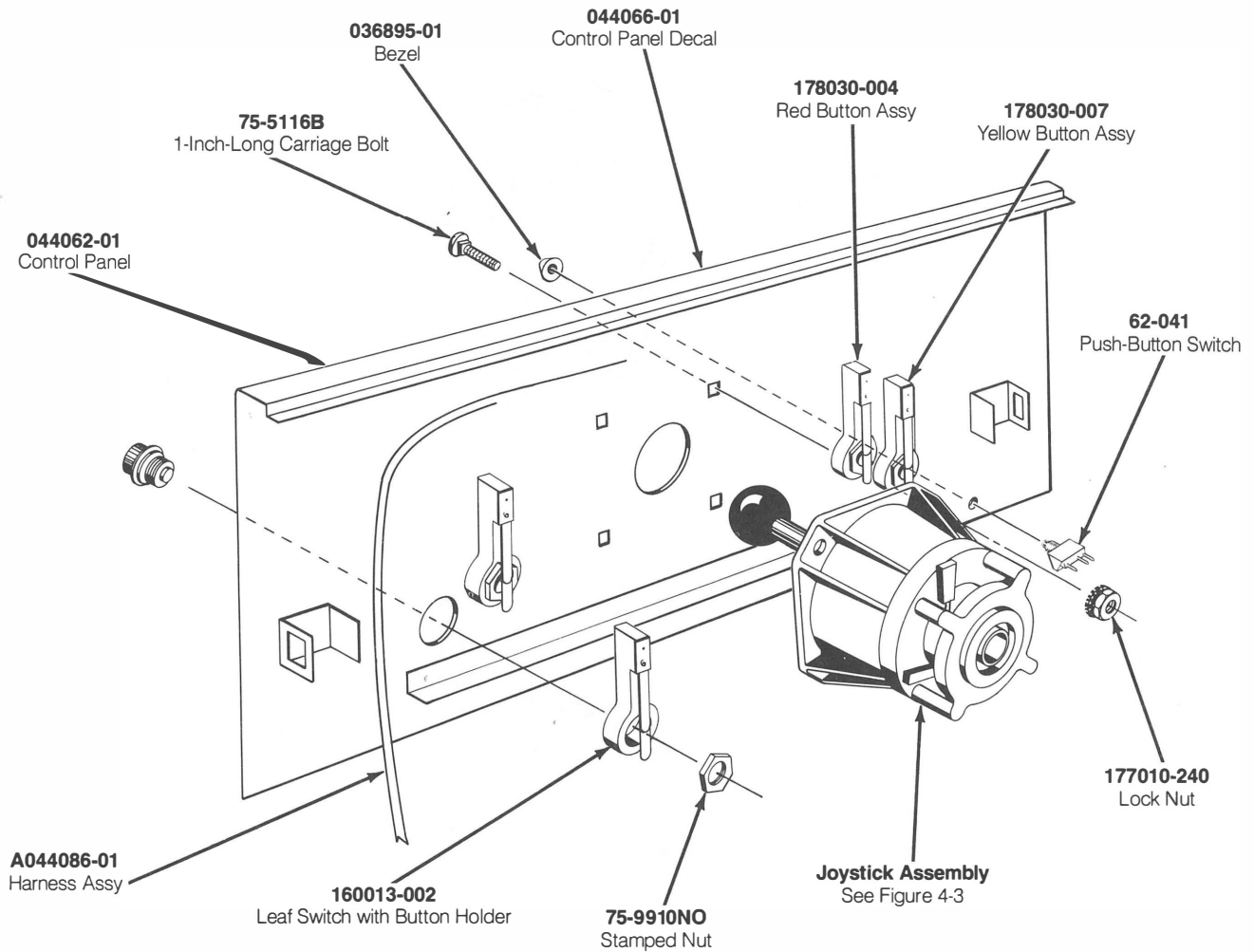

Figure 4-1 Cabinet-Mounted Assemblies, Continued

Cabinet-Mounted Assemblies Parts List

Part No.	Description
A043055-01	On/Off Switch Assembly with Harness
A043086-05	Ground Strap Assembly
A043377-01	Display Power Harness Assembly
A043424-01	Locking Bar Assembly (optional—can be used with either brand of coin door)
A044063-01	Graphics Panel Assembly
A044068-01	Cabinet Assembly
A044081-01	Power Harness Assembly
A044082-01	Video Harness Assembly
A044083-01	Speaker Harness Assembly
A044084-01	Coin Harness Assembly
78-3201	Adjustable Glide
78-6900404	¼-Inch-Wide × ¼-Inch-Thick Foam Tape (24 inches required; used on top underside lip of speaker grille)
009992-01	On/Off Switch Cover
034536-02	0.50-Inch-Thick Foam Vibration Damper
037332-01	Louvered Grille
038091-01	Molded Coin Box
042914-01	Ventilation Grille
043583-01	Rear Access Panel with Lock
043595-01	Speaker Grille
043596-01	19-Inch Video Display Bezel
044065-01	Left-Side Panel Decal
044065-02	Right-Side Panel Decal
043594-01	Tinted Video Display Shield; used with part no. 139017-001 OR
044067-01	Clear Video Display Shield; used with part no. 139017-204
139017-001	Wells-Gardner 19-Inch Clear Color Raster Video Display OR
139017-204	Wells-Gardner 19-Inch Tinted Color Raster Video Display
148007-104	4½-Inch Round, 8Ω, 10W, Shielded Speaker
171078-002	Non-Resettable Counter, 12 VDC
178013-001	Spring Draw Latch
	<i>The following items are technical information supplements for this game:</i>
TM-300	Rolling Thunder Operators Manual
TM-283	Wells-Gardner 19-Inch Color Raster Video Display Service Manual; used with part no. 139017-001
SP-300	Rolling Thunder Schematic Package Supplement
ST-300	Rolling Thunder Self-Test Label
99-131014	Wells-Gardner 19-Inch Color Raster Video Display Service Manual; used with part no. 139017-204



**Figure 4-2 Control Panel Assembly
A044061-01 A**

**Control Panel Assembly
Parts List**

Part No.	Description
A040934-01	4-Position Leaf Switch Joystick Assembly
A044086-01	Control Panel Harness Assembly
62-041	Black Cap (No LED) SPDT Push-Button Switch
75-5116B	#10-24 × 1.00-Inch-Long Black Carriage Bolt
75-9910NO	#11 3/8-Inch Stamped Nut
036895-01	Black Molded Bezel
044062-01	Control Panel
044066-01	Control Panel Decal
160013-002	Cross-Bar Leaf Switch with Button Holder
177010-240	#10-24 Lock Nut
178030-004	Red Button Assembly
178030-007	Yellow Button Assembly

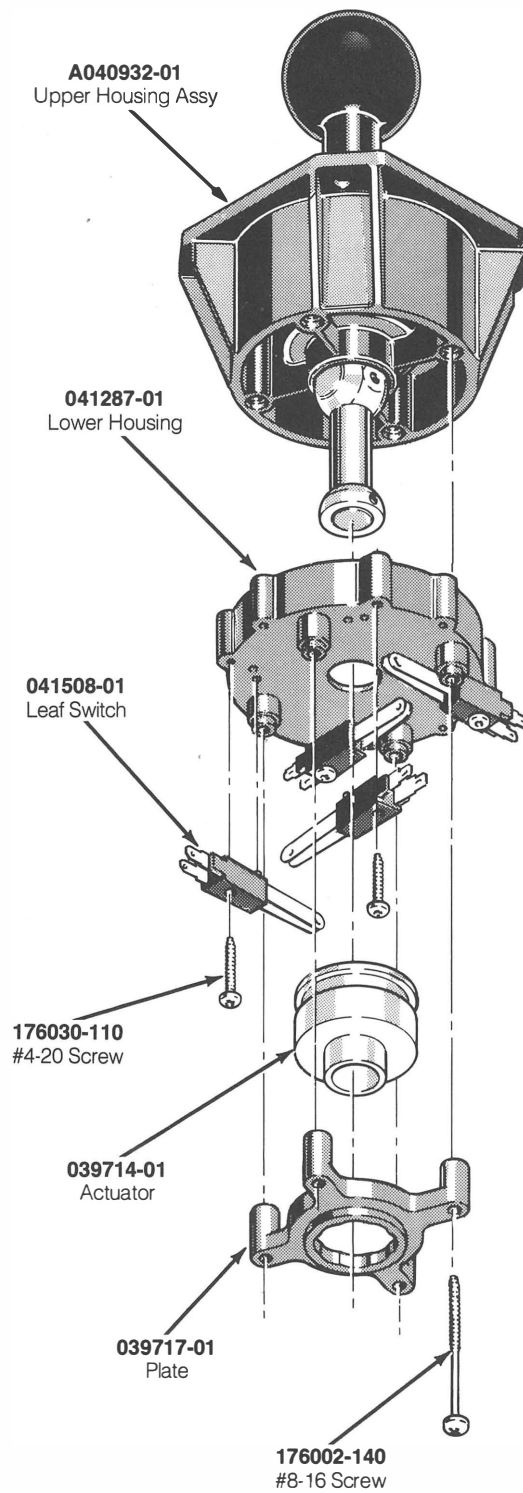
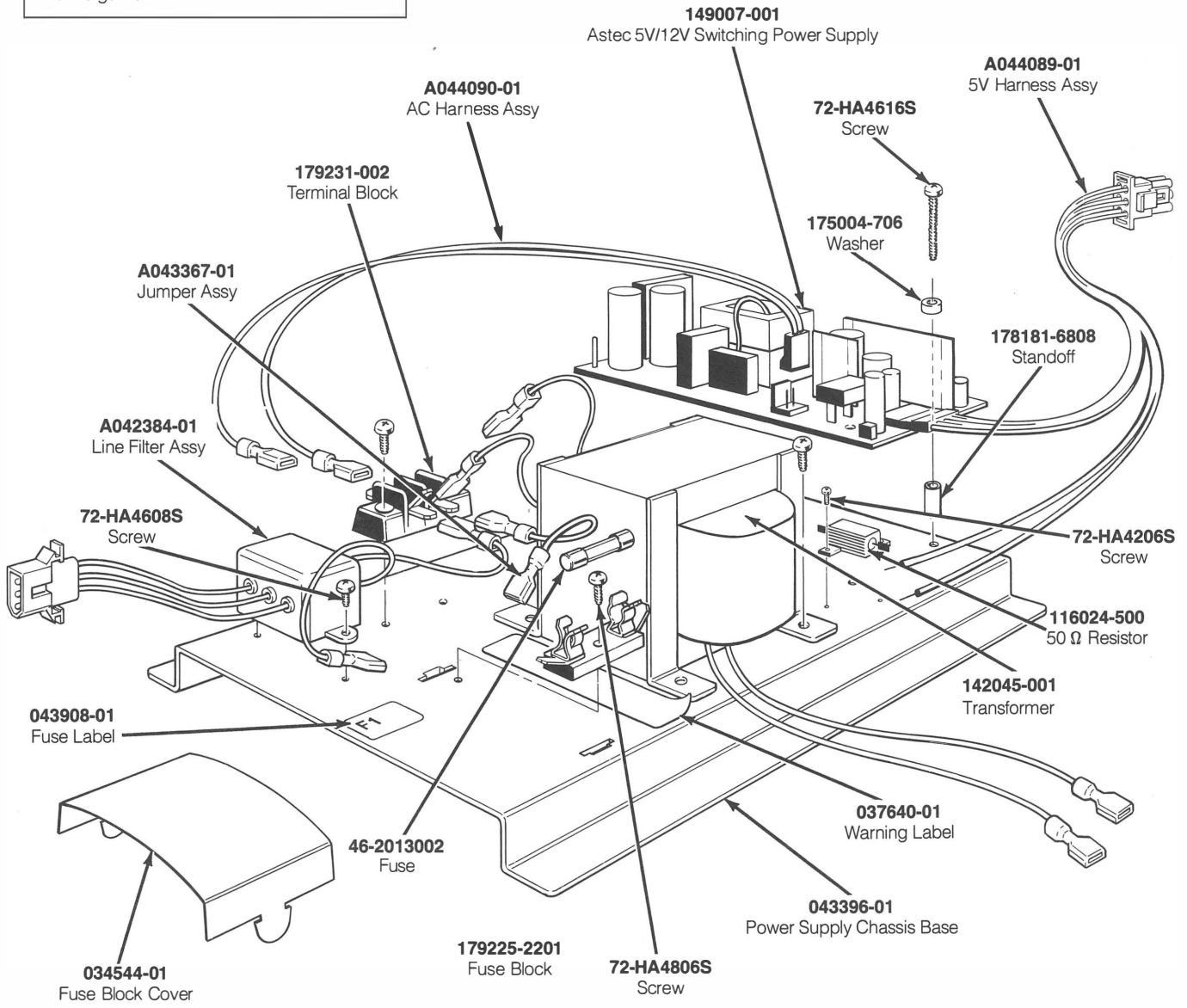

**Figure 4-3 Joystick Assembly
A040934-01 B**

Joystick Assembly Parts List

Part No.	Description
A040932-01	Upper Housing Assembly
041287-01	Lower Housing
041508-01	Leaf Switch
039714-01	Actuator
039717-01	4-Position Positioner Plate
176002-140	#8-16 × 2.50-Inch-Long Self-Tapping Hex Washer-Head Screw
176030-110	#4-20 × .62-Inch-Long Hex Washer-Head Self-Tapping Screw

⚠ WARNING ⚠
 The switching power supply has high volt-ages on it when power is turned on. There-fore, be sure you *do not touch this power supply* unless you have turned off the power to the game.



**Figure 4-4 Switching/Linear (SL) Power Supply Assembly
 A044074-01 A**

Switching/Linear (SL) Power Supply Assembly Parts List

Part No.	Description
A042384-01	Line Filter Assembly
A043367-01	Jumper Assembly
A044089-01	5 V Harness Assembly
A044090-01	AC Harness Assembly
46-2013002	250 V Slow-Blow 3 A Fuse
72-HA4206S	#4-32 × 3/8-Inch Cross-Recessed Pan-Head Thread-Forming Screw
72-HA4608S	#6-32 × 1/2-Inch Cross-Recessed Pan-Head Thread-Forming Screw
72-HA4616S	#6-32 × 1-Inch Cross-Recessed Pan-Head Thread-Forming Screw
72-HA4806S	#8-32 × 3/8-Inch Cross-Recessed Pan-Head Thread-Forming Screw
034544-01	Fuse Block Cover
037640-01	Power Supply Warning Label
043396-01	Power Supply Chassis Base
043908-01	Power Supply Fuse Label
116024-500	50 Ω, 5 W, Chassis-Mount, Wirewound Resistor
142045-001	Transformer
149007-001	Astec 5 V/12 V Switching Power Supply
175004-706	#6 Fiber Washer
178181-6808	.171-Inch ID, 1/4-Inch OD, Aluminum Standoff
179225-2201	1-Position Fuse Block
179231-002	2-Position Terminal Block

Astec 5-Volt Power Supply Sub-Assembly Model SA40-1304 Parts List

Designator	Description	Part No.
Capacitors		
C1, C2	Capacitor, Met Poly, .1 μF, ± 20%, 250 VAC	99-209076
C3, C4	Capacitor, Poly, 2200 pF, ± 20%, 250 VAC	99-209077
C5	Capacitor, Met Poly, 2200 pF, ± 20%, 250 V	99-209080
C8	Capacitor, Electrolytic, 220 μF, + 100 - ± 10%, 10 V	99-209072
C9	Capacitor, Ceramic, 1000 pF, ± 20%, 3 KV, Z5P	99-209068
C10	Capacitor, Met Poly, .022 μF, ± 20%, 250 VAC	99-209079
C11	Capacitor, Poly, .22 μF, ± 10%, 100 V	99-209014
C12	Capacitor, Electrolytic, 2200 μF, ± 20%, 16 V, Sxa	99-209073
C13	Capacitor, Poly, .01 μF, ± 5%, 50 V	99-209075
C14	Capacitor, Electrolytic, 100 μF, ± 20%, 25 V, Sxa	99-209006
C15	Capacitor, Electrolytic, 1000 μF, ± 20%, 16 V, Sxa	99-209008
C16	Capacitor, Poly, .022 μF, ± 20%, 50 V	99-209078
C17	Capacitor, Electrolytic, 1000 μF, ± 20%, 10 V, Sm	99-209071
C18	Capacitor, Ceramic, 330 pF, ± 20%, 100 V, Sl	99-209069
C19	Capacitor, Electrolytic, 470 μF, ± 20%, 16 V, Sm	99-209074
C20	Capacitor, Electrolytic, 100 μF, ± 20%, 16 V, Sm	99-209070
C21	Capacitor, Poly, .22 μF, ± 10%, 100 V	99-209014
C23	Capacitor, Ceramic, .01 μF, + 80- ± 20%, 100 V, Z5U	99-209003
Diodes		
D1	Diode, RGP10A	99-209083
D2	Diode, RGP10J	99-209033

**Astec 5-Volt Power Supply Sub-Assembly
Model SA40-1304 Parts List, Continued**

Designator	Description	Part No.
D3	Diode, GP10A	99-209084
D4, D5	Diode, RGP10J	99-209033
D6, D7	Diode, 1N4606	99-209030
D8	Assembly, Regulator/SCR/Diode/Heat Sink	99-209105
D8	Diode, 12CTQ035	99-209107
D9	Diode, RGP10B	99-209034
D10	Assembly, Diode/Heat Sink	99-209103
D11	Diode, 1N4606	99-209030
D12, D13	Diode, 1N4001	99-209035
DB1	Diode, Bridge, KBP08	99-209085
Inductors		
L3	Inductor, 2.2 μ H	99-209029
L4	Inductor, 1.5 mH	99-209028
L5	Assembly, Inductor Coil	99-209059
L6	Inductor, 4.4 μ H	99-209102
Transistors		
Q1	Transistor, NPN, 2SC2120	99-209082
Q2	Assembly, Transistor/Heat Sink	99-209104
Q3	Transistor, PNP, 2SB561	99-209022
Resistors		
R1	Resistor, Carbon Film, 470K Ω , \pm 5%, 1/2 W	99-209089
R2	Resistor, Wirewound, 33 Ω , \pm 5%, 3 W	99-209097
R3, R4	Resistor, Metal Oxide Film, 100K Ω , \pm 5%, 1 W	99-209054
R5	Resistor, Carbon Film, 1K Ω , \pm 5%, 1/4 W	99-209086
R6	Resistor, Metal Oxide Film, 120 Ω , \pm 5%, 2 W	99-209095
R7	Resistor, Metal Film, 1 Ω , \pm 5%, 1 W	99-209025
R8	Resistor, Carbon Film, 27 Ω , \pm 5%, 1/4 W	99-209040
R9	Resistor, Carbon Film, 68 Ω , \pm 5%, 1/4 W	99-209090
R10	Resistor, Carbon Film, 10 Ω , \pm 5%, 1/4 W	99-209037
R11	Resistor, Carbon Film, 15 Ω , \pm 5%, 1/4 W	99-209087
R12	Resistor, Metal Film, .75 Ω , \pm 5%, 1 W	99-209091
R13	Resistor, Carbon Film, 5.6 Ω , \pm 5%, 1/4 W	99-209046
R14	Resistor, Carbon Film, 47 Ω , \pm 5%, 1/4 W	99-209043
R15, R16	Resistor, Carbon Film, 270 Ω , \pm 5%, 1/2 W	99-209041
R17	Resistor, Carbon Film, 8.2 Ω , \pm 5%, 1/4 W	99-209049
R18	Resistor, Carbon Film, 330 Ω , \pm 5%, 1/4 W	99-209042
R19	Resistor, Carbon Film, 56 Ω , \pm 5%, 1/4 W	99-209045
R20	Resistor, Carbon Film, 68 Ω , \pm 5%, 1/4 W	99-209090
R21	Resistor, Carbon Film, 330 Ω , \pm 5%, 1/4 W	99-209042
R22	Resistor, Carbon Film, 470 Ω , \pm 5%, 1/4 W	99-209044
R23	Resistor, Metal Film, 8.2K Ω , \pm 1%, 1/4 W	99-209094
R24	Resistor, Metal Film, 2.7K Ω , \pm 1%, 1/4 W	99-209093
R25	Resistor, Metal Film, 18K Ω , \pm 1%, 1/4 W	99-209092
R27	Resistor, Carbon Film, 22 Ω , \pm 5%, 1/4 W	99-209088
R28	Resistor, Carbon Film, 10 Ω , \pm 5%, 1/4 W	99-209037
R29	Resistor, Metal Oxide Film, 120 Ω , \pm 5%, 2 W	99-209095

**Astec 5-Volt Power Supply Sub-Assembly
Model SA40-1304 Parts List, Continued**

Designator	Description	Part No.
R30	Resistor, Wirewound, 15 Ω , \pm 5%, 5 W	99-209096
R32	Resistor, Carbon Film, 10 Ω , \pm 5%, 1/4 W	99-209037
Transformers		
T1	Com Mode Transformer Assembly	99-209101
T2	Transformer, Power, AC8154	99-209100
T3	Control Transformer Assembly (J/V)	99-209058
Miscellaneous		
F1	Fuse, 2 A, 250 V	99-209081
IC1	Regulator, 431	99-209023
IC2	Assembly, Regulator/SCR/Diode/Heat Sink	99-209105
IC2	Regulator, UA7912	99-209106
SCR1	Assembly, Regulator/SCR/Diode/Heat Sink	99-209105
SCR1	Thyristor, SCR, 2N6395	99-209108
TM1, TM2	Thermistor, 8 Ω , \pm 20%	99-209099
VR1	Potentiometer, Trimming, 1K Ω	99-209098
Z1	Diode, Zener, 5.6 V, \pm 5%, 40 mA	99-209031

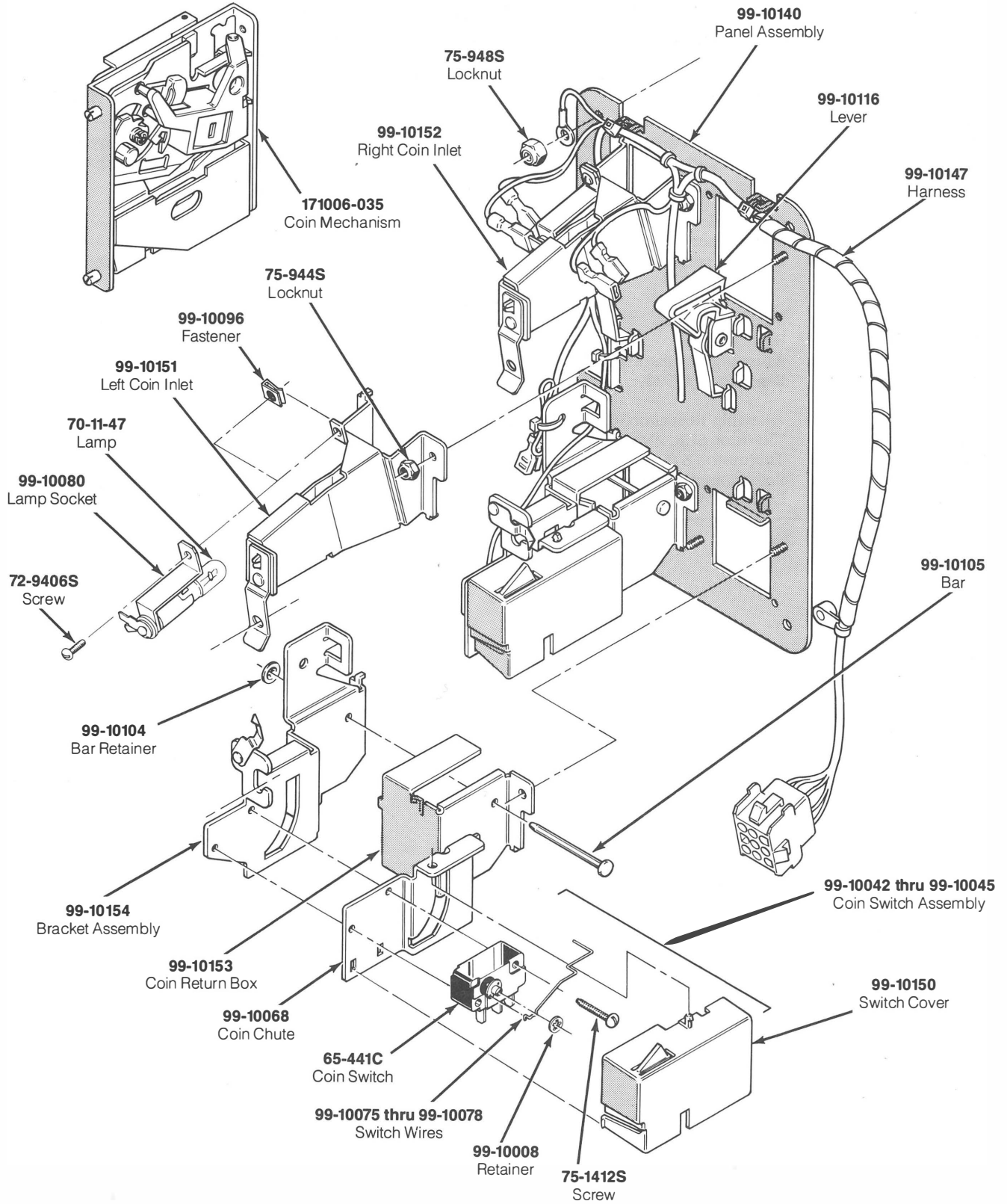

**Figure 4-5 Coin Acceptors, Inc. Coin Door Assembly
171027-001 A**

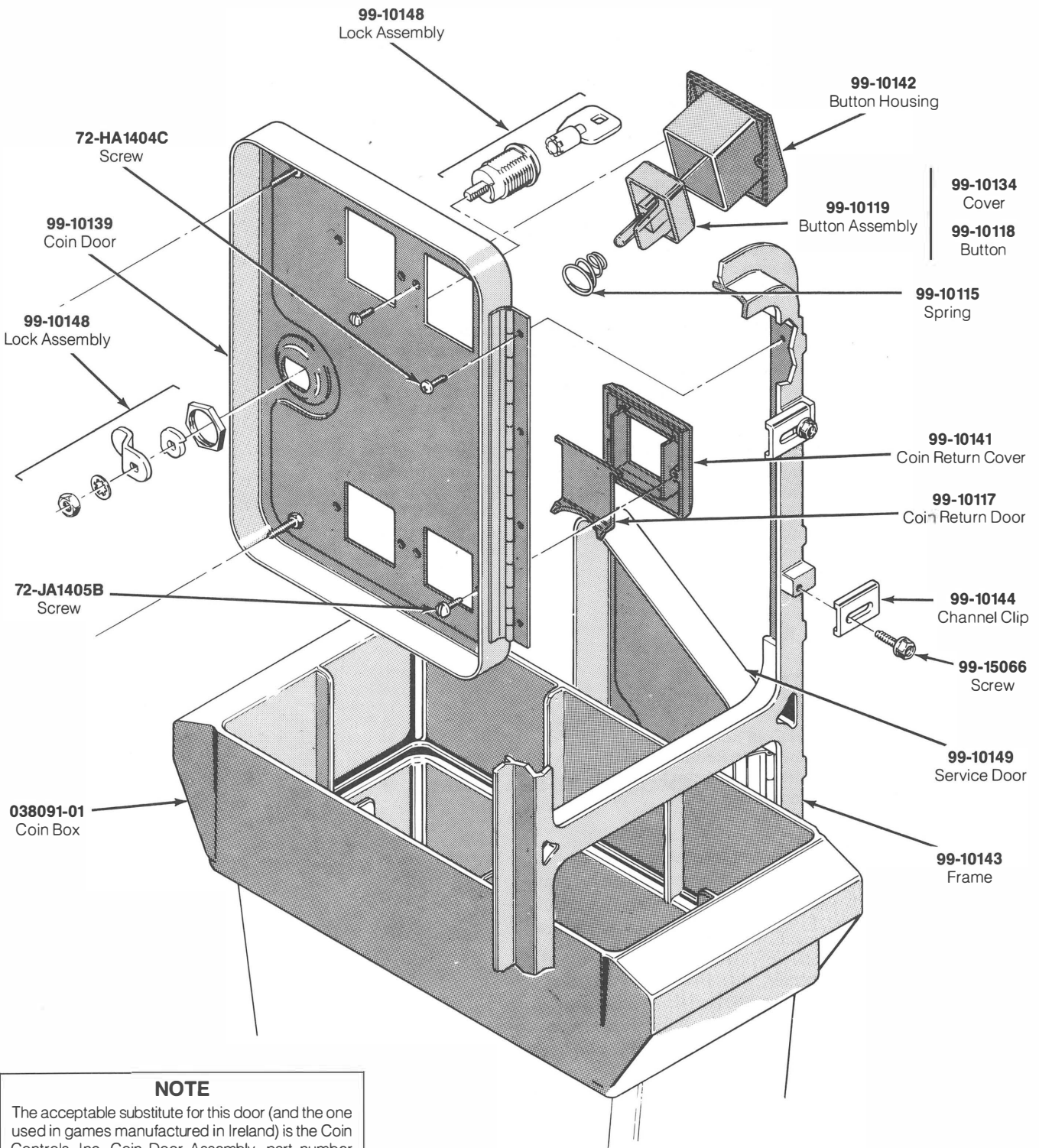

Figure 4-5 Coin Acceptors, Inc. Coin Door Assembly, Continued
171027-001 A

Coin Acceptors, Inc. Coin Door Assembly Parts List

Part No.	Description
65-441C	Coin Switch
70-11-47	Miniature Bayonet Lamp
72-9406S	#4-40 × 3/8-Inch Truss-Head Screw
72-HA1404C	#4-40 × 1/4-Inch Pan-Head Screw
72-JA1405B	#4-40 × 0.31-Inch Pan-Head Screw
75-1412S	#4-40 × 3/4-Inch Pan-Head Screw
75-994S	#4-40 Locknut
99-10008	Retainer
99-10042	Coin Switch Assembly for Belgian 5 Fr and U.S. \$.25
99-10043	Coin Switch Assembly for German 1 DM, Japanese 100 Yen, Swiss 1 Fr
99-10044	Coin Switch Assembly for German 2 DM, Italian 100 L, U.S. \$1.00
99-10045	Coin Switch Assembly for Australian \$.20, German 5 DM, British 10 P
99-10068	Coin Return Chute
99-10075	Switch Wire (included in coin switch assembly 99-10043)
99-10076	Switch Wire (included in coin switch assembly 99-10042)
99-10077	Switch Wire (included in coin switch assembly 99-10044)
99-10078	Switch Wire (included in coin switch assembly 99-10045)
99-10080	Lamp Socket
99-10081	Key Holder
99-10096	Fastener
99-10104	Bar Retainer
99-10105	Bar
99-10115	Spring
99-10116	Plastic Coin Return Lever
99-10117	Steel Coin Return Door
99-10118	Amber Coin Return Button
99-10119	Amber Coin Button for U.S. \$.25
99-10134	Coin Button Cover
99-10139	Coin Door
99-10140	Coin Door Inner-Panel Assembly
99-10141	Die-Cast Coin Return Cover
99-10142	Die-Cast Button Housing
99-10143	Coin Door Frame
99-10144	Channel Clip
99-10147	Harness
99-10148	Lock Assembly
99-10149	Service Door
99-10150	Switch Cover
99-10151	Left Coin Inlet
99-10152	Right Coin Inlet
99-10153	Coin Return Box
99-10154	Bracket Assembly
99-15066	Screw for Clamp
171006-035	Metal Coin Mechanism for U.S. \$.25

N O T E S

NOTICE TO ALL PERSONS RECEIVING THIS DRAWING

CONFIDENTIAL: Reproduction forbidden without the specific written permission of Atari Games Corporation, Milpitas, CA. This drawing is only conditionally issued, and neither receipt nor possession thereof confers or transfers any right in, or license to use, the subject matter of the drawing or any design or technical information shown thereon, nor any right to reproduce this drawing or any part thereof. Except for manufacture by vendors of Atari Games Corporation, and for manufacture under the corporation's written license, no right is granted to reproduce this drawing or the subject matter thereof, unless by written agreement with or written permission from the corporation.

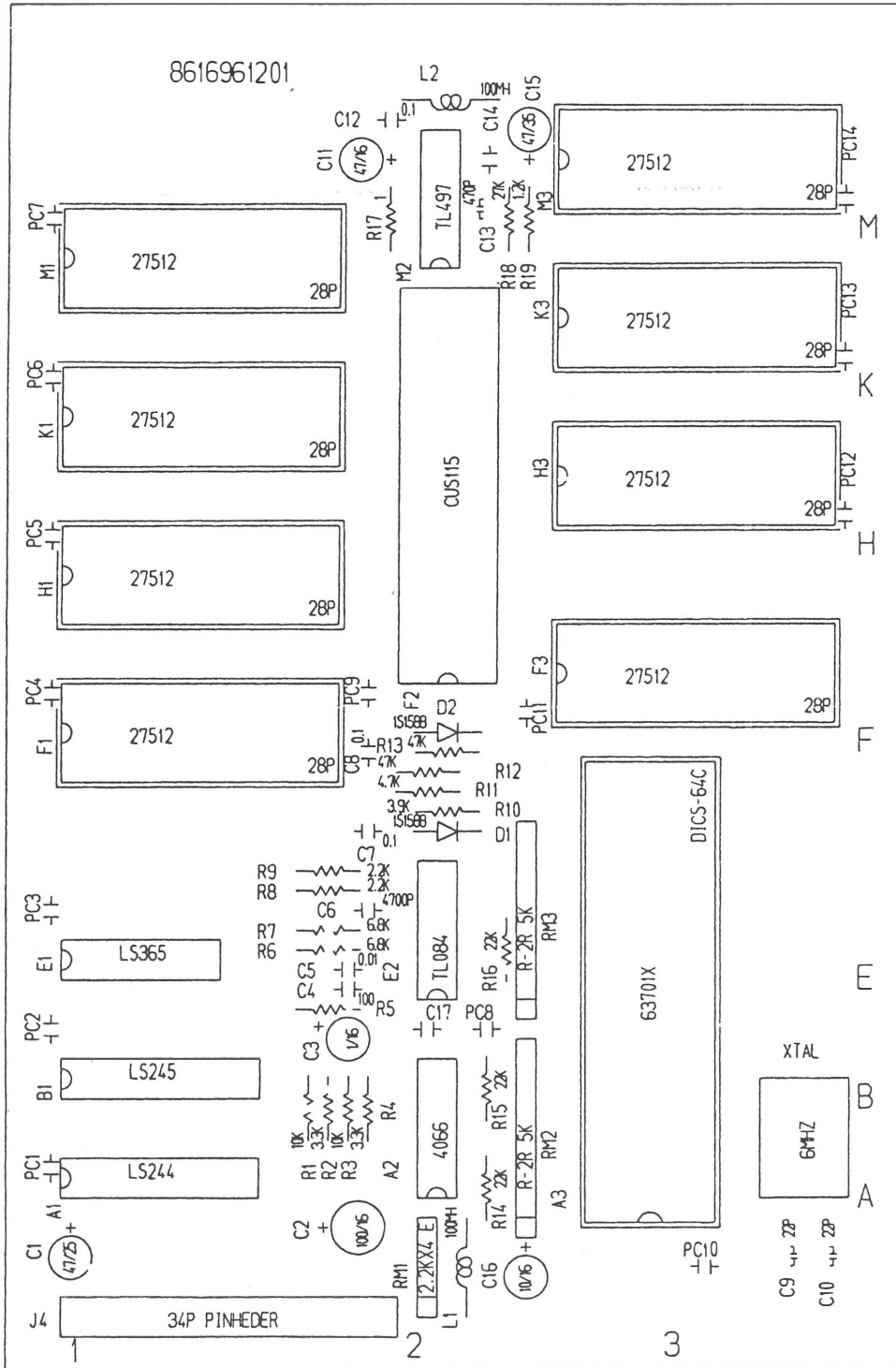

Figure 4-6, Continued Rolling Thunder Sub PCB Assembly 99-090285

Rolling Thunder Game PCB Assembly Parts List

Designator	Description	Part No.	Designator	Description	Part No.
Integrated Circuits					
1E	IC, Custom 98	99-090156	8U	IC, 74LS74	99-090115
1F, 1J	IC, Custom 95	99-090155	8V	IC, 74LS174	99-090123
2E	IC, Custom 99	99-090157	9A	IC, 68A09EP	99-090135
2F, 2J	IC, Custom 95	99-090155	9A	IC, HD68A09E	99-090134
3A	IC, Power Amplifier, LA4460	99-090160	9C	IC, PR EPROM, RT2-1, 27256, 250 ns, 9C	99-090223
3F	IC, M5M5165-70 (70 ns)	99-090142	9E	IC, 74LS245	99-090124
3F	IC, MB81C78-45 (45 ns)	99-090143	9F	IC, 74LS375	99-090129
3F	IC, MB8464 A-70 (70 ns)	99-090144	9M	IC, Custom 48	99-090154
3F	IC, TMM2063P-70 (70 ns)	99-090145	9N	IC, 74S08	99-090220
3F	IC, TMM2064P-70 (70 ns)	99-090146	9P	IC, Custom 27	99-090148
3H	IC, 74LS08	99-090111	9V	IC, 74LS174	99-090123
3J, 3K	IC, 74HC257	99-090132	10C	IC, Custom 47	99-090153
3L, 3M	IC, 74LS257	99-090125	10M	IC, M5M5165P-10 (100 ns)	99-090140
3R	IC, PR EPROM, RT1-1, 7124, 45 ns, 3R	99-090239	10M	IC, TMM2064P-10 (100 ns)	99-090141
3S	IC, PR EPROM, RT1-2, 7116, 45 ns, 3S	99-090240	10N	IC, 74LS138	99-090117
3T, 3U, 3V	IC, 74LS173	99-090122	10P, 10R	IC, 74LS173	99-090122
4A	IC, Op-Amp, LM324N	99-090159	10S	IC, 74LS378	99-090131
4C	IC, DAC, YM3012	99-090158	10T	IC, 74LS173	99-090122
4F	IC, Custom 30	99-090149	11A	IC, 68A09EP	99-090135
4N	IC, M5M5165P-10 (100 ns)	99-090140	11A	IC, HD68A09E	99-090134
4N	IC, TMM2064P-10 (100 ns)	99-090141	11D-11F	IC, 74LS257	99-090125
4U	IC, 74LS273	99-090126	11H	IC, 74LS377	99-090130
4V	IC, PR EProm, RT1-3, 7138, 45 ns, 4V	99-090241	11K	IC, CXK5813D-45 (45 ns)	99-090137
5A	IC, YM2151	99-090147	11K	IC, Custom 95	99-090155
5B	IC, 4069	99-090133	11K	IC, TMM2018D-45 (45 ns)	99-090136
5K	IC, Custom 42	99-090151	11K	IC, TMM2016BP-10 (100 ns)	99-090139
5U	IC, 74LS158	99-090121	11N	IC, Custom 39	99-090150
5V	IC, PR EPROM, RT1-4, 7138, 45 ns, 5V	99-090242	11U	IC, CXK5813D-45 (45 ns)	99-090137
6C	IC, 74LS245	99-090124	11U	IC, CXK5808P-45 (45 ns)	99-090138
6E	IC, 74LS32	99-090114	11U	IC, TMM2018D-45 (45 ns)	99-090136
6N	IC, Custom 43	99-090152	11V	IC, CXK5808P-45 (45 ns)	99-090138
6U	IC, PR EPROM, RT1-5, 7112, 35 ns, 6U	99-090243	11V	IC, CXK5813D-45 (45 ns)	99-090137
6V	IC, 74F174	99-090221	11V	IC, TMM2018D-45 (45 ns)	99-090136
7B	IC, 74LS373	99-090127	12A	IC, 74LS02	99-090109
7C	IC, 74LS257	99-090125	12C	IC, PR EPROM, RT2-2, 27256, 250 ns, 12C	99-090224
7D	IC, 74LS139	99-090118	12E	IC, 74LS245	99-090124
7E	IC, 74LS10	99-090112	12H	IC, PR EPROM, RT1-9, 27512, 250 ns, 12H	99-090231
7F	IC, 74LS04	99-090110	12K	IC, PR EPROM, RT1-10, 27512, 250 ns, 12K	99-090232
7H	IC, 74F20	99-090113	12L	IC, PR EPROM, RT1-11, 27512, 250 ns, 12L	99-090233
7K	IC, Custom 42	99-090151	12M	IC, PR EPROM, RT1-12, 27512, 250 ns, 12M	99-090234
7N	IC, M5M5165P-10 (100 ns)	99-090140	12P	IC, PR EPROM, RT1-13, 27512, 250 ns, 12P	99-090235
7N	IC, TMM2064P-10 (100 ns)	99-090141	12R	IC, PR EPROM, RT1-14, 27512, 250 ns, 12R	99-090236
7S	IC, PR EPROM, RT1-8, 27256, 250 ns, 7S	99-090230	12T	IC, PR EPROM, RT1-15, 27512, 250 ns, 12T	99-090237
7U	IC, 74LS158	99-090121	12U	IC, PR EPROM, RT1-16, 27512, 250 ns, 12U	99-090238
7V	IC, 74LS85	99-090116	Capacitors		
8B	IC, 74LS257	99-090125	C1	Capacitor, Electrolytic, 470 μ F, 10 V	99-090168
8C	IC, 74LS157	99-090120	C2	Capacitor, Electrolytic, 1000 μ F, 25 V	99-090169
8D	IC, 74LS00	99-090108	C3	Capacitor, Electrolytic, 47 μ F, 6.3 V	99-090167
8E	IC, 74LS08	99-090111	C4	Capacitor, Electrolytic, 2.2 μ F, 25 V	99-090165
8F	IC, 74LS153	99-090119			
8H	IC, 74LS374	99-090128			
8N	IC, Custom 43	99-090152			

Rolling Thunder Game PCB Assembly Parts List, Continued

Designator	Description	Part No.	Designator	Description	Part No.
C5	Capacitor, Electrolytic, 22 μ F, 16 V	99-090166	PC26, PC29,	Capacitor, Ceramic, 0.1 μ F, 25 V	99-090175
C6, C7	Capacitor, Ceramic, .033 μ F, 50 V, \pm 10%	99-090180	PC30	Capacitor, Ceramic, 0.1 μ F, 25 V	99-090175
C8, C9	Capacitor, Ceramic, 0.01 μ F, 25 V	99-090174	PC33-PC36	Capacitor, Ceramic, 0.1 μ F, 25 V	99-090175
C10, C11	Capacitor, Electrolytic, 10 μ F, 16 V	99-090170	PC38, PC40	Capacitor, Ceramic, 0.1 μ F, 25 V	99-090175
C12	Capacitor, Ceramic, 470 pF, 25 V	99-090173	PC41	Capacitor, Tantalum, TSD-A 4.7 μ F, 10 V	99-090177
C13	Capacitor, Ceramic, .0022 μ F, 50 V, \pm 5%	99-090179	PC41	Capacitor, Tantalum, TSD-S 4.7 μ F, 10 V	99-090176
C14	Capacitor, Electrolytic, 10 μ F, 16 V	99-090170	PC42-PC45	Capacitor, Ceramic, 0.1 μ F, 25 V	99-090175
C15, C16	Capacitor, Ceramic, 22 pF, 25 V	99-090171	PC46	Capacitor, Tantalum, TSD-S 4.7 μ F, 10 V	99-090176
C17, C18	Capacitor, Ceramic, 100 pF, 25 V	99-090172	PC46	Capacitor, Tantalum, TSD-A 4.7 μ F, 10 V	99-090177
C20-C22	Capacitor, Ceramic, 220 pF, 25 V	99-090178	PC47	Capacitor, Ceramic, 0.1 μ F, 25 V	99-090175
Diodes			Resistors		
D1	Diode, Zener, RD6.2F (1 W, 5.8-6.6 V)	99-090164	R1, R2	Resistor, 4.7 Ω , \pm 5%, 1/4 W	99-090187
Connectors and Sockets			R3	Resistor, 15K Ω , \pm 5%, 1/4 W	99-090197
J1	Connector, Pin Housing, 3CKT	99-090222	R4	Resistor, 6.8K Ω , \pm 5%, 1/4 W	99-090195
J4	Socket, 34CKT	99-090207	R5	Resistor, 15K Ω , \pm 5%, 1/4 W	99-090197
J5	Socket, 20CKT	99-090206	R6	Resistor, 680 Ω , \pm 5%, 1/4 W	99-090188
	Socket, IC, 14CKT	99-090216	R7	Resistor, 18K Ω , \pm 5%, 1/4 W	99-090200
	Socket, IC, 16CKT	99-090210	R8	Resistor, 22K Ω , \pm 5%, 1/4 W	99-090198
	Socket, IC, 20CKT	99-090211	R9	Resistor, 10K Ω , \pm 5%, 1/4 W	99-090196
	Socket, IC, 22CKT	99-090214	R10	Resistor, 390 Ω , \pm 5%, 1/4 W	99-090190
	Socket, IC, 24CKT	99-090213	R11	Resistor, 560 Ω , \pm 5%, 1/4 W	99-090192
	Socket, IC, 24CKT	99-090212	R12	Resistor, 1Meg Ω , \pm 5%, 1/4 W	99-090199
	Socket, IC, 28CKT	99-090215	R13	Resistor, 330 Ω , \pm 5%, 1/4 W	99-090189
	Socket, IC, 40CKT	99-090217	R14	Resistor, 10K Ω , \pm 5%, 1/4 W	99-090196
	Socket, IC, 42CKT	99-090218	R15	Resistor, 4.7K Ω , \pm 5%, 1/4 W	99-090194
	Socket, IC, 64CKT	99-090219	R16	Resistor, 1K Ω , \pm 5%, 1/4 W	99-090193
Oscillators			R17	Resistor, 470 Ω , \pm 5%, 1/4 W	99-090191
OSC	Oscillator, MCO-1425B (49.152 MHz)	99-090162	R18	Resistor, 180 Ω , \pm 5%, 1/4 W	99-090201
OSC	Oscillator, KXO-01-49M152	99-090161	R19	Resistor, 1K Ω , \pm 5%, 1/4 W	99-090193
Polarized Capacitors			Resistor Modules		
PC1	Capacitor, Tantalum, TSD-S 4.7 μ F, 10 V	99-090176	RM1	Resistor, SIP Network, 220 Ohm \times 4, 1/8 W	99-090181
PC1	Capacitor, Tantalum, TSD-A 4.7 μ F, 10 V	99-090177	RM2	Resistor, SIP Network, 470 Ohm \times 4, 1/8 W	99-090182
PC3	Capacitor, Ceramic, 0.1 μ F, 25 V	99-090175	RM3	Resistor, SIP Network, 1K Ohm \times 4, 1/8 W	99-090183
PC4	Capacitor, Tantalum, TSD-S 4.7 μ F, 10 V	99-090176	RM4	Resistor, SIP Network, 2.2K Ohm \times 4, 1/8 W	99-090184
PC4	Capacitor, Tantalum, TSD-A 4.7 μ F, 10 V	99-090177	RM5, RM6	Resistor, SIP Network, 4.7K Ohm \times 8, 1/8 W	99-090185
PC5	Capacitor, Ceramic, 0.1 μ F, 25 V	99-090175	RM7-RM9	Resistor, SIP Network, 10K Ohm \times 4, 1/8 W	99-090186
PC7	Capacitor, Tantalum, TSD-A 4.7 μ F, 10 V	99-090177	Switches		
PC7	Capacitor, Tantalum, TSD-S 4.7 μ F, 10 V	99-090176	SWA	Switch, DIP, 8CKT	99-090205
PC8	Capacitor, Tantalum, TSD-A 4.7 μ F, 10 V	99-090177	SWA	Switch, DIP, 8CKT	99-090204
PC8	Capacitor, Tantalum, TSD-S 4.7 μ F, 10 V	99-090176	SWB	Switch, DIP, 8CKT	99-090204
PC9	Capacitor, Ceramic, 0.1 μ F, 25 V	99-090175	SWB	Switch, DIP, 8CKT	99-090205
PC10	Capacitor, Tantalum, TSD-S 4.7 μ F, 10 V	99-090176	Miscellaneous		
PC10	Capacitor, Tantalum, TSD-A 4.7 μ F, 10 V	99-090177	T1-T3	Terminal, Fast-on Tab, .250	99-090208
PC11-PC14	Capacitor, Ceramic, 0.1 μ F, 25 V	99-090175	VR1	Potentiometer, Trimming, 2K Ω , TM10K (PV)	99-090203
PC15	Capacitor, Tantalum, TSD-A 4.7 μ F, 10 V	99-090177	VR1	Potentiometer, Trimming, 2K Ω , TM10K (PV) 8US	99-090202
PC15	Capacitor, Tantalum, TSD-S 4.7 μ F, 10 V	99-090176	X1	Crystal, 3.579545 MHz	99-090163
PC16-PC21	Capacitor, Ceramic, 0.1 μ F, 25 V	99-090175			
PC24	Capacitor, Tantalum, TSD-A 4.7 μ F, 10 V	99-090177			
PC24, PC25	Capacitor, Tantalum, TSD-S 4.7 μ F, 10 V	99-090176			
PC25	Capacitor, Tantalum, TSD-A 4.7 μ F, 10 V	99-090177			

Rolling Thunder Sub PCB Assembly Parts List

Designator	Description	Part No.	Designator	Description	Part No.
Integrated Circuits			Connectors		
A1	IC, 74LS244	99-090244	J4	Connector, Header, 34CKT	99-090276
A2	IC, 4066	99-090246	Inductors		
A3	IC, HD637A01X0	99-090247	L1, L2	Inductor, 100 mH, SP0406-101K	99-090274
B1	IC, 74LS245	99-090124	Polarized Capacitors		
E1	IC, 74LS365	99-090245	PC1-PC14	Capacitor, Ceramic, .01 μ F, 12 V	99-090265
E2	IC, Op-amp, TL084CN	99-090248	Resistors		
F1	IC, PR EPROM, RT1-17, 27512, 250NS, F1	99-090278	R1	Resistor, 10K Ω , \pm 5%, $\frac{1}{4}$ W	99-090196
F2	IC, 115	99-090251	R2	Resistor, 3.3K Ω , \pm 5%, $\frac{1}{4}$ W	99-090258
F3	IC, PR EPROM, RT1-21, 27512, 250NS, F3	99-090282	R3	Resistor, 10K Ω , \pm 5%, $\frac{1}{4}$ W	99-090196
H1	IC, PR EPROM, RT1-18, 27512, 250NS, H1	99-090279	R4	Resistor, 3.3K Ω , \pm 5%, $\frac{1}{4}$ W	99-090258
H3	IC, PR EPROM, RT2-22, 27512, 250NS, H3	99-090283	R5	Resistor, 100 Ω , \pm 5%, $\frac{1}{4}$ W	99-090255
K1	IC, PR EPROM, RT2-19, 27512, 250NS, K1	99-090280	R6, R7	Resistor, 6.8K Ω , \pm 5%, $\frac{1}{4}$ W	99-090195
M1	IC, PR EPROM, RT1-20, 27512, 250NS, M1	99-090281	R8, R9	Resistor, 2.2K Ω , \pm 5%, $\frac{1}{4}$ W	99-090257
M2	IC, Regulator, TL497ACN	99-090249	R10	Resistor, 3.9K Ω , \pm 5%, $\frac{1}{4}$ W	99-090259
Capacitors			R11	Resistor, 4.7K Ω , \pm 5%, $\frac{1}{4}$ W	99-090194
C1	Capacitor, Electrolytic, 47 μ F, 25 V	99-090271	R12, R13	Resistor, 47K Ω , \pm 5%, $\frac{1}{4}$ W	99-090261
C2	Capacitor, Electrolytic, 100 μ F, 16 V	99-090273	R14-R16	Resistor, 22K Ω , \pm 5%, $\frac{1}{4}$ W	99-090198
C3	Capacitor, Electrolytic, 1 μ F, 16 V	99-090268	R17	Resistor, 1 Ω , \pm 5%, $\frac{1}{4}$ W	99-090254
C5	Capacitor, Ceramic, .01 μ F, \pm 10%, 50 V	99-090267	R18	Resistor, 27K Ω , \pm 5%, $\frac{1}{4}$ W	99-090260
C6	Capacitor, Ceramic, .0047 μ F, \pm 10%, 50 V	99-090266	R19	Resistor, 1.2K Ω , \pm 5%, $\frac{1}{4}$ W	99-090256
C7, C8	Capacitor, Ceramic, .01 μ F, 12 V	99-090265	Resistor Modules		
C9, C10	Capacitor, Ceramic, 22 pF, 12 V	99-090262	RM1	Resistor, SIP Network, 2.2K $\Omega \times 4$, $\frac{1}{8}$ W	99-090252
C11	Capacitor, Electrolytic, 47 μ F, 16 V	99-090270	RM2, RM3	Resistor, SIP Network, 5K $\Omega \times 8$	99-090253
C12	Capacitor, Ceramic, .01 μ F, 12 V	99-090265	Miscellaneous		
C13	Capacitor, Ceramic, 470 pF, 12 V	99-090263	XTAL	Crystal, 6.000 MHz	99-090275
C14	Capacitor, Ceramic, 0.1 μ F, 50 V	99-090264		Socket, IC, 64CKT	99-090219
C15	Capacitor, Electrolytic, 47 μ F, 35 V	99-090272		Socket, IC, 28CKT	99-090215
C16	Capacitor, Electrolytic, 10 μ F, 16 V	99-090269			
C17	Capacitor, Ceramic, 0.1 μ F, 50 V	99-090264			
Diodes					
D1, D2	Diode, 1S1588	99-090250			

NOTICE TO ALL PERSONS RECEIVING THIS DRAWING

CONFIDENTIAL: Reproduction forbidden without the specific written permission of Atari Games Corporation, Milpitas, CA. This drawing is only conditionally issued, and neither receipt nor possession thereof confers or transfers any right in, or license to use, the subject matter of the drawing or any design or technical information shown thereon, nor any right to reproduce this drawing or any part thereof. Except for manufacture by vendors of Atari Games Corporation, and for manufacture under the corporation's written license, no right is granted to reproduce this drawing or the subject matter thereof, unless by written agreement with or written permission from the corporation.

NOTE: Components R1-R7, TP1, and TP2 should *not* be installed in the PCB.

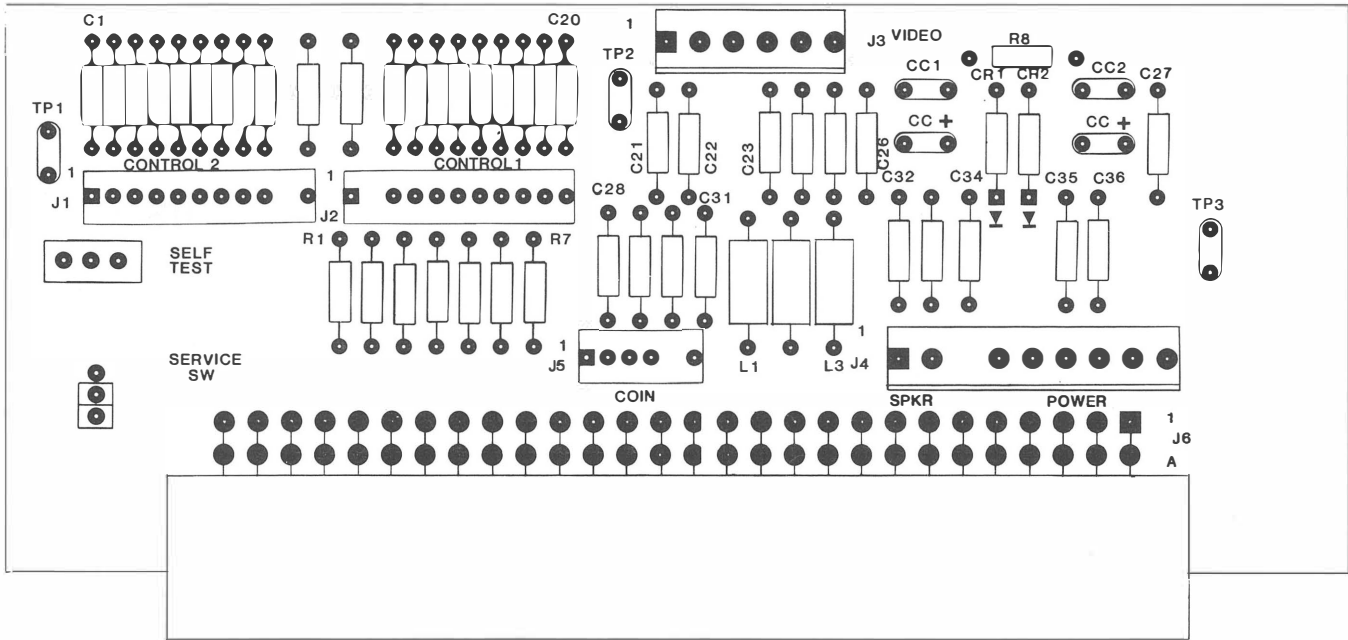

**Figure 4-7 End PCB Assembly
A044201-01 A**

**End PCB Assembly
Parts List**

Designator	Description	Part No.
Capacitors		
C1-C21	.1 μ F, 50 V Ceramic Capacitor	122002-104
C22	.001 μ F, 50 V Ceramic Capacitor	122002-102
C23-C25	470 pF, 100 V Ceramic Capacitor	122016-471
C26-C31	.1 μ F, 50 V Ceramic Capacitor	122002-104
C32, C33	.01 μ F, 25 V Ceramic Capacitor	122005-103
C34-C36	.1 μ F, 50 V Ceramic Capacitor	122002-104
Diodes		
CR1, CR2	Type-1N4001 Diode	31-1N4001
Connectors		
J1, J2	11-Ckt., .1-Inch Ctr. Header Connector	179118-011
J3	6-Ckt., .156-Inch Ctr. Header Connector	179213-006
J4	9-Ckt., .156-Inch Ctr. Header Connector	179213-009
J5	6-Ckt., .1-Inch Ctr. Header Connector	179118-006
J6	56-Ckt., Right-Angle Edge Connector (Acceptable substitute is part no. 179240-156)	179240-056
Resistors		
R8	0 Ω , \pm 5%, 1/4 W Resistor	110005-001
Miscellaneous		
L1-L3	Ferrite Bead	141003-005
CC +, CC +	Test Point, .187 \times .031	179051-001
TP3	Test Point, .250 \times .031	179051-003
	SPDT Miniature Slide Self-Test Switch	69-004
	2-Ckt., .1-Inch Ctr., Header Connector (Service Switch)	179118-002

N O T E S

Warranty

Seller warrants that its printed-circuit boards and parts thereon are free from defects in material and workmanship under normal use and service for a period of ninety (90) days from date of shipment. Seller warrants that its video displays and laser video disc players (in games supplied with displays and video-disc players) are free from defects in material and workmanship under normal use and service for a period of thirty (30) days from date of shipment. None of the Seller's other products or parts thereof are warranted.

If the products described in this manual fail to conform to this warranty, Seller's sole liability shall be, at its option, to repair, replace, or credit Buyer's account for such products which are returned to Seller during said warranty period, provided:

- (a) Seller is promptly notified in writing upon discovery by Buyer that said products are defective;
- (b) Such products are returned prepaid to Seller's plant; and
- (c) Seller's examination of said products discloses to Seller's satisfaction that such alleged defects existed and were not caused by accident, misuse, neglect, alteration, improper repair, installation, or improper testing.

In no event shall Seller be liable for loss of profits, loss of use, incidental or consequential damages.

Except for any express warranty set forth in a written contract between Seller and Buyer which contract supersedes the terms herein, this warranty is expressed in lieu of all other warranties expressed or implied, including the implied warranties of merchantability and fitness for a particular purpose, and of all other obligations or liabilities on the Seller's part, and it neither assumes nor authorizes any other person to assume for the Seller any other liabilities in connection with the sale of products by Seller.

The use of any non-Atari parts may void your warranty, according to the terms of the warranty. The use of any non-Atari parts may also adversely affect the safety of your game and cause injury to you and others. Be very cautious in using non-Atari-supplied components with our games, in order to ensure your safety.

Atari distributors are independent, being privately owned and operated. In their judgment they may sell parts or accessories other than Atari parts or accessories. Atari Games Corporation cannot be responsible for the quality, suitability or safety of any non-Atari part or any modification including labor which is performed by such distributor.



Atari Games Corporation
675 Sycamore
P.O. Box 361110
Milpitas, California 95035