

PAPERBOY™

Operators manual with illustrated parts lists



Atari Games, Inc. Customer Service

If reading through this manual does not lead to solving a certain maintenance problem, call TELEHELP® at one of these Atari Games Customer Service offices:

UNITED STATES

Parts and Service

Atari Games Corporation
California Customer Service Office
737 Sycamore Drive
P.O. Box 906
Milpitas, CA 95035
Telex 17-2976
(Monday–Friday, 7:30–4:00 pm Pacific Time)



(408) 434-3950

EUROPE

Parts and Service

Atari Games Corporation
European Customer Service Office
Tipperary Town, Ireland
Telex 28165
(Monday–Friday, 9:00–6:00 pm GMT)



062-52155

SYSTEM

PAPERBOY™

Operators manual with illustrated parts lists

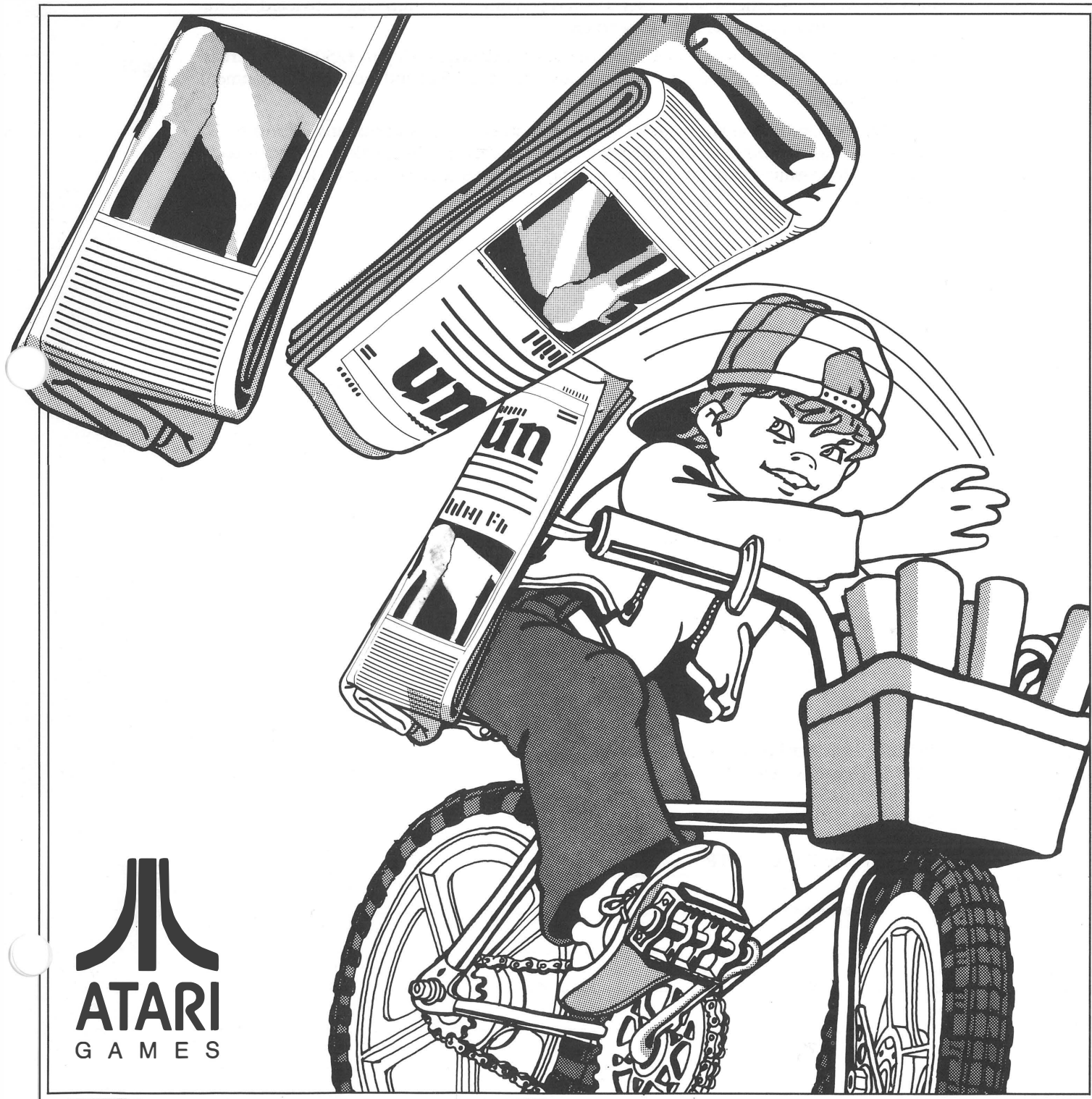

ATARI
GAMES

© 1985 by Atari Games Corporation

All rights reserved.

No part of this publication may be reproduced by any mechanical, photographic, or electronic process, or in the form of a phonographic recording, nor may it be stored in a retrieval system, transmitted, or otherwise copied for public or private use, without permission from the publisher.

The game play, all graphic designs, this technical manual, its accompanying schematic diagrams, and the display manual are protected by the U.S. Copyright Act of 1976.

This Act provides for increased penalties for violating federal copyright laws. Courts *can impound* infringing articles while legal action is pending. If infringers are convicted, courts can *order destruction* of the infringing articles.

In addition, the Act provides for payment of statutory damages of up to \$250,000 in certain cases. Infringers may also have to pay costs and attorneys' fees and face an imprisonment of up to five years.

Atari Games Corporation will aggressively enforce its copyrights against any infringers. *We will use all legal means* to immediately halt any manufacture, distribution, or operation of a copy of video games made by us. Anyone who purchases such copies risks forfeiting such a game.

Published by: Atari Games Corporation
1272 Borregas Avenue
P.O. Box 3618
Sunnyvale, California 94088

Printed in the U.S.A. **1P**

Notice Regarding Non-ATARI Parts

⚠ WARNING ⚠

Use of non-ATARI® parts or modifications of any ATARI game circuitry may adversely affect the safety of your game, and may cause injury to you and your players.

You may void the game warranty (printed on the inside back cover of this manual) if you do any of the following:

- Substitute non-ATARI parts in the game.
- Modify or alter any circuits in the game by using kits or parts *not* supplied by Atari Games Corporation.

NOTE

This equipment generates, uses, and can radiate radio frequency energy and if not installed and used in accordance with the instruction manual, may cause interference to radio communications. It has been tested and found to comply with the limits for a Class A computing device pursuant to Subpart J of Part 15 of Federal Communications Commission (FCC) Rules, which are designed to provide reasonable protection against such interference when operated in a commercial environment. Operation of this equipment in a residential area or modification to this equipment is likely to cause interference in which case the user, at his own expense, will be required to take whatever measures may be required to correct the interference. If you suspect interference from an ATARI® game at your location, check the following:

- All green ground wires in the game are properly connected as shown in the game wiring diagram.
- The power cord is properly plugged into a grounded three-wire outlet.
- The game printed-circuit boards (PCB) are properly installed with the Electromagnetic Interference (EMI) ground plane.

If you are still unable to solve the interference problem, please contact Customer Service at Atari Games Corporation. See the inside front cover of this manual for service in your area.

Table of Contents

1	Set-Up	
	How to Use This Manual.....	1-1
	Inspecting the Game.....	1-2
	Control and Switch Locations.....	1-2
	Coin and Game Option Settings.....	1-2
	Operating Modes.....	1-4
	Game Play.....	1-6
	Operator Hints.....	1-7
2	Self-Test	
	RAM/Interrupt/ROM Test.....	2-2
	6502 Processor Test.....	2-2
	Control Test.....	2-4
	Calibration Procedure.....	2-4
	Alphanumeric Test.....	2-4
	Scrolling Playfield Test.....	2-4
	Motion Object Test.....	2-5
	Motion Object Height Test.....	2-5
	Color Bar Test.....	2-5
	Color Purity Test.....	2-6
	Convergence Test.....	2-6
	Accounting Information.....	2-6
	Switch Settings.....	2-7
3	Maintenance	
	Preventive Maintenance	3-2
	Preventive-Maintenance Intervals.....	3-2
	Removing the Control Panel.....	3-2
	Lubricating and Tightening the Handlebar Control.....	3-2
	Cleaning the Coin Mechanism.....	3-2
	Cleaning the Interior Components.....	3-3
	Corrective Maintenance	3-4
	Removing the Video Display.....	3-4
	Removing the Game PCBs.....	3-5
	Removing the Fluorescent-Light Assembly.....	3-7
	Removing the Speakers.....	3-7
	Disassembling the Handlebar Control.....	3-7
	Aligning the Handlebar Control Potentiometers.....	3-15
	Calibrating the Handlebar Control.....	3-16
4	Troubleshooting	
	Troubleshooting Procedures.....	4-2
	Troubleshooting Techniques.....	4-2
	Soldering Techniques.....	4-2
	Troubleshooting Static-Sensitive Devices.....	4-4
5	Illustrated Parts List	
	See List of Illustrations on next page.	
	Appendix: Installation	
	Kit Parts Inventory.....	A-3
	Tools Required.....	A-3
	Installation Instructions.....	A-3
	Setting the Coin and Game Options.....	A-9

List of Illustrations

Figure 1-1	Game Overview	1-3
Figure 1-2	Control and Switch Locations	1-4
Figure 2-1	RAM Test Fails	2-2
Figure 2-2	Interrupt Test Fails.....	2-2
Figure 2-3	ROM Test Fails.....	2-2
Figure 2-4	Reset Retry.....	2-3
Figure 2-5	Communications Fails	2-3
Figure 2-6	Music/RAM/ROM Fails	2-3
Figure 2-7	Sound Output	2-3
Figure 2-8	Sound Status	2-3
Figure 2-9	Control Test Passes.....	2-4
Figure 2-10	Alphanumeric Test	2-4
Figure 2-11	Scrolling Playfield Test	2-4
Figure 2-12	Motion Object Test	2-5
Figure 2-13	Motion Object Height Test	2-5
Figure 2-14	Color Bar Test	2-5
Figure 2-15	Color Purity Test.....	2-6
Figure 2-16	Convergence Test	2-6
Figure 2-17	Accounting Information.....	2-6
Figure 2-18	Switch Settings.....	2-7
Figure 3-1	Control Panel Removal	3-3
Figure 3-2	Video Display Removal	3-4
Figure 3-3	Game PCB Removal	3-5
Figure 3-4	Fluorescent-Light Assembly Removal	3-8
Figure 3-5	Speaker Removal	3-8
Figure 3-6	Handlebar Control Removal.....	3-9
Figure 3-7	Torsion Spring and Modification Bearing Installation.....	3-10
Figure 3-8	Accelerator Unit Disassembly/Reassembly	3-11
Figure 3-9	Steering Unit Disassembly/Reassembly	3-13
Figure 4-1	Removing IC (Cut-Pin Method)	4-3
Figure 4-2	Removing IC Pins	4-3
Figure 4-3	Removing Solder from Plated-Through Holes	4-4
Figure 4-4	Removing Solder from Lead Connection Pads.....	4-4
Figure 5-1	Cabinet-Mounted Assemblies	5-2
Figure 5-2	Control Panel Assembly	5-5
Figure 5-3	Handlebar Control Assembly	5-6
Figure 5-4	Fluorescent Tube Assembly.....	5-9
Figure 5-5	Power Supply Assembly	5-10
Figure 5-6	Utility Panel Assembly.....	5-12
Figure 5-7	Coin Controls, Inc. Coin Door Assembly	5-13
Figure 5-8	Coin Acceptors, Inc. Coin Door Assembly	5-16
Figure 5-9	Printed-Circuit Board Mounting Hardware	5-20
Figure 5-10	Central Processing Unit PCB Assembly.....	5-22
Figure 5-11	Video PCB Assembly.....	5-30
Figure 5-12	Regulator/Audio III PCB Assembly	5-38
Figure A-1	Kit Part Locations	A-2
Figure A-2	Attraction Film Replacement	A-4
Figure A-3	Control Panel Replacement	A-4
Figure A-4	Video Display Removal and Replacement.....	A-5
Figure A-5	Game ROM Replacement	A-7

List of Tables

Table 1-1	Game Specifications.....	1-2
Table 1-2	Coin and Credit Settings.....	1-5
Table 1-3	Game Option Settings	1-5
Table A-1	Kit Parts Inventory	A-3

Safety Summary

The following safety precautions apply to all game operators and service personnel. Specific warnings and cautions will be found throughout this manual where they apply.

WARNING

Properly Ground the Game. Players may receive an electrical shock if this game is not properly grounded! To avoid electrical shock, do not plug in the game until it has been inspected and properly grounded. This game should only be plugged into a grounded three-wire outlet. If you have only a two-wire outlet, we recommend you hire a licensed electrician to install a grounded outlet. Players may receive an electrical shock if the control panel is not properly grounded! After servicing any parts on the control panel, check that the grounding clip is firmly secured to the metal tab on the inside of the control panel. Only then should you lock up the game.

AC Power Connection. Before connecting the game to the AC power source, verify that the proper voltage-selection plug is installed on the game's power supply.

Disconnect Power During Repairs. To avoid electrical shock, disconnect the game from the AC power source before removing or repairing any part of the game. When removing or repairing the video display, extra precautions must be taken to avoid electrical shock because high voltages may exist within the display circuitry and cathode-ray tube (CRT) even after power has been disconnected. Do not touch internal parts of the display with your hands or with metal objects! Always discharge the high voltage from the CRT before servicing this area of the game. To discharge the CRT: Attach one end of a large, well-insulated, 18-gauge jumper wire to ground. Momentarily touch the free end of the grounded jumper to the CRT anode by sliding it under the anode cap. Wait two minutes and discharge the anode again.

Use Only ATARI Parts. To maintain the safety integrity of your ATARI game, do not use non-ATARI parts when repairing the game. Use of non-ATARI parts or other modifications to the game circuitry may adversely affect the safety of your game, and injure you or your players.

Handle Fluorescent Tube and CRT With Care. If you drop a fluorescent tube or CRT and it breaks, it may implode! Shattered glass can fly six feet or more from the implosion.

Use the Proper Fuses. To avoid electrical shock, use replacement fuses which are specified in the parts list for this game. Replacement fuses must match those replaced in fuse type, voltage rating, and current rating. In addition, the fuse cover must be in place during game operation.

CAUTION

Properly Attach All Connectors. Make sure that the connectors on each printed-circuit board (PCB) are properly plugged in. Note that they are keyed to fit only one way. If they do not slip on easily, do not force them. A reversed connector may damage your game and void the warranty.

Ensure the Proper AC Line Frequency. Video games manufactured for operation on 60 Hz line power (i.e., United States) must not be operated in countries with 50 Hz line power (i.e., Europe). The fluorescent light ballast transformer will overheat, causing a potential fire hazard if 60 Hz games are operated on power lines using 50 Hz. Check the product identification label of your game for the line frequency required.

Set-Up

How to Use This Manual

Your System II™ cabinet is designed to be used for a variety of games. The System II cabinet comes with a System II game installed at the factory or, if you already have a System II game, any available System II game can be purchased as a kit for easy installation. This operators manual is for the PAPERBOY™ game, and is supplied either with System II cabinets that have the PAPERBOY game installed at the factory or with PAPERBOY kits that can be installed in the field.

This manual includes information for setting up, playing, and maintaining your System II PAPERBOY game. If you have purchased a PAPERBOY kit to change an existing System II game into a PAPERBOY game, the Appendix of this manual contains all the necessary information for installing the PAPERBOY game kit.

This manual is divided into the following chapters:

- Chapter 1 contains set-up information.
- Chapter 2 contains self-test procedures.
- Chapter 3 contains preventive and corrective maintenance procedures.
- Chapter 4 contains troubleshooting information.
- Chapter 5 contains illustrated parts lists.
- The Appendix contains procedures for installing the PAPERBOY kit.

Schematic diagrams for the System II PAPERBOY game circuitry are in the SP-275 Schematic Package Supplement included with this manual.

This chapter includes information required to set up and play your PAPERBOY game. Carefully read the information in this chapter before applying power to the game.



WARNING

To avoid electrical shock, do not plug in the game until it has been properly inspected and set up for the line voltage in your area.

This game should only be connected to a grounded three-wire outlet. If you have only a two-wire outlet, we recommend you hire a licensed electrician to install a grounded outlet. Players may receive an electrical shock if the game is not properly grounded.

Do not touch internal parts of the display with your hands or with metal objects.



Chapter 1

Inspecting the Game

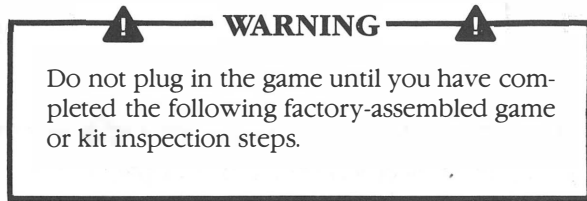

Please inspect your System II PAPERBOY game (or kit) carefully to ensure that the game (or kit) is complete and delivered to you in good condition. Figure 1-1 shows the locations of the component parts of the assembled game. Refer to Appendix A for a list of the kit parts. Table 1-1 lists space, power, and environmental requirements.

Inspect the factory-assembled game as follows:

1. Examine the exterior of the cabinet for dents, chips, or broken parts.
2. Unlock and open the rear-access door. Unlock and open the coin doors. Inspect the interior of the cabinet as follows:
 - a. Ensure that all plug-in connectors (on the cabinet harnesses) are firmly plugged in. Do not force connectors together. The connectors are keyed so they only fit in the proper orientation. *A reversed edge connector may damage a printed-circuit board (PCB) and will void your warranty.*
 - b. Ensure that all plug-in integrated circuits on each PCB are firmly plugged into their sockets.
 - c. Inspect the power cord for any cuts or dents in the insulation.
 - d. Inspect the power supply. Make sure that the correct fuses are installed and that the voltage plugs are inserted for the proper line voltage. Check that the harness is plugged in correctly and that the fuse-block cover is mounted in place. Check that the green ground wire is connected.
 - e. Inspect other major sub-assemblies, such as the video display, printed-circuit boards (PCBs), speakers, and the fluorescent tube. Make sure they are mounted securely and that the green ground wires are connected.

Inspect the PAPERBOY kit as follows:

1. Check that all the PAPERBOY kit parts listed in Appendix A are included in your kit.
2. Examine the kit parts for dents, chips, or broken parts.

Table 1-1 Game Specifications

Characteristic	Specification
Power Consumption	315 V-A, 260 W RMS maximum with kit parts installed
Temperature	+ 5 to + 38 C (+ 37 to + 100 F)
Humidity	Not to exceed 95% relative
Line Voltage	100 to 132 VAC (or 200 to 264 VAC)
Width	25.25 in. (64 cm)
Depth	37 in. (94 cm)
Height	72 in. (183 cm)
Weight	350 lbs. (159 kg) maximum with kit parts installed

Control and Switch Locations

Power On/Off Switch

The power on/off switch is located at the bottom rear of the cabinet (see Figure 1-1).

Volume Control

The volume control is located on the utility panel behind the upper coin door (see Figures 1-1 and 1-2). The volume control adjusts the level of sound produced by the game.

Auxiliary Coin Switch

The auxiliary coin switch is located on the coin mechanism.

Coin Counters

The coin counter(s) are located on the utility panel behind the upper coin door. The coin counter(s) record the number of coins entered.

Self-Test Switch

The self-test switch is located on the utility panel behind the upper coin door. The self-test switch selects the Self-Test Mode to check game operation. Refer to Chapter 2 for a complete description of self-test operation.

Coin and Game Option Settings

The System II cabinet has two dual-in-line package (DIP) option switches located on the CPU printed-circuit board (PCB).

- The option switch at location 6/7A is for selecting coin options.
- The option switch at location 5/6A is for selecting game options.

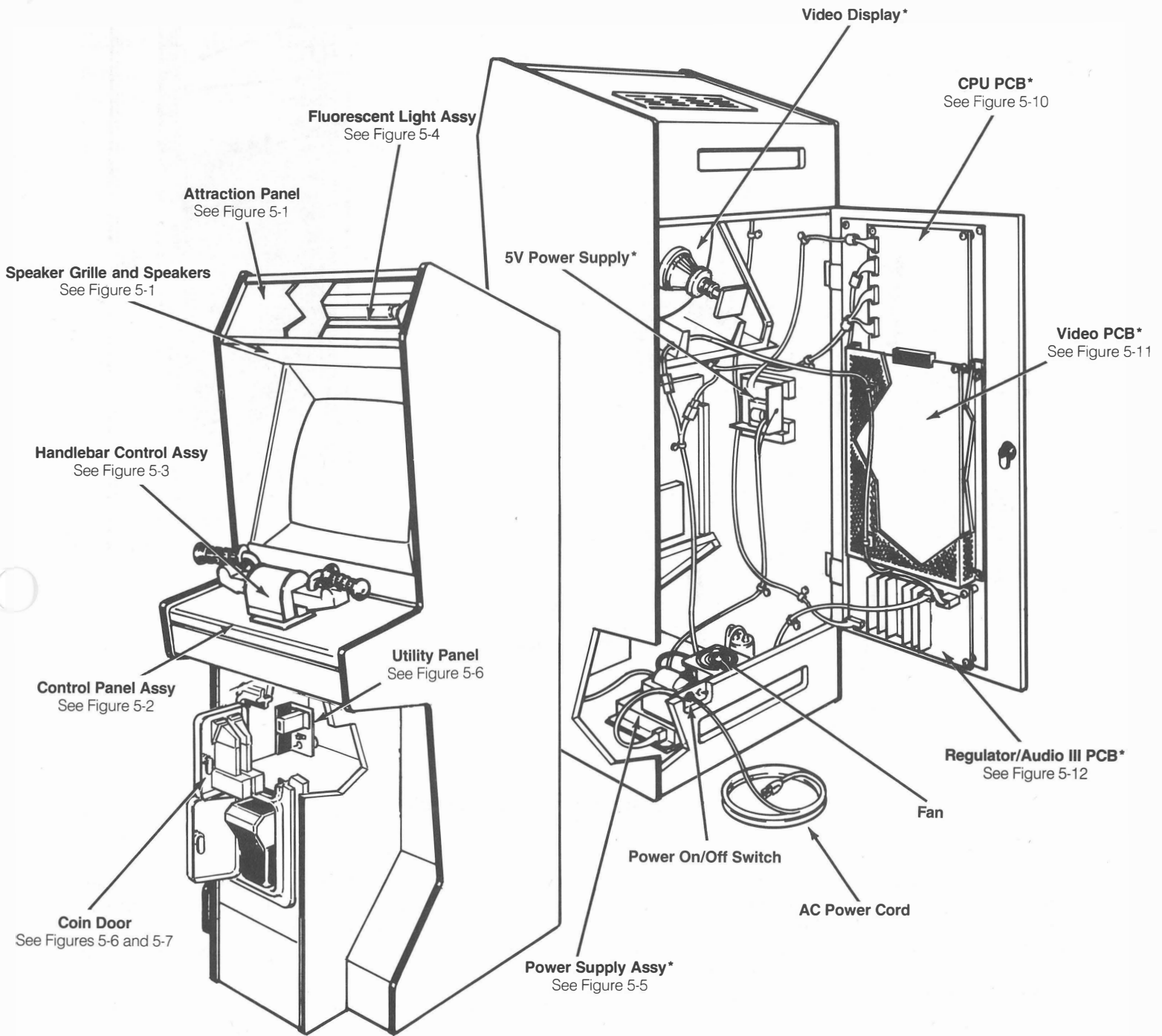

*Items with a serial number label

Figure 1-1 Game Overview

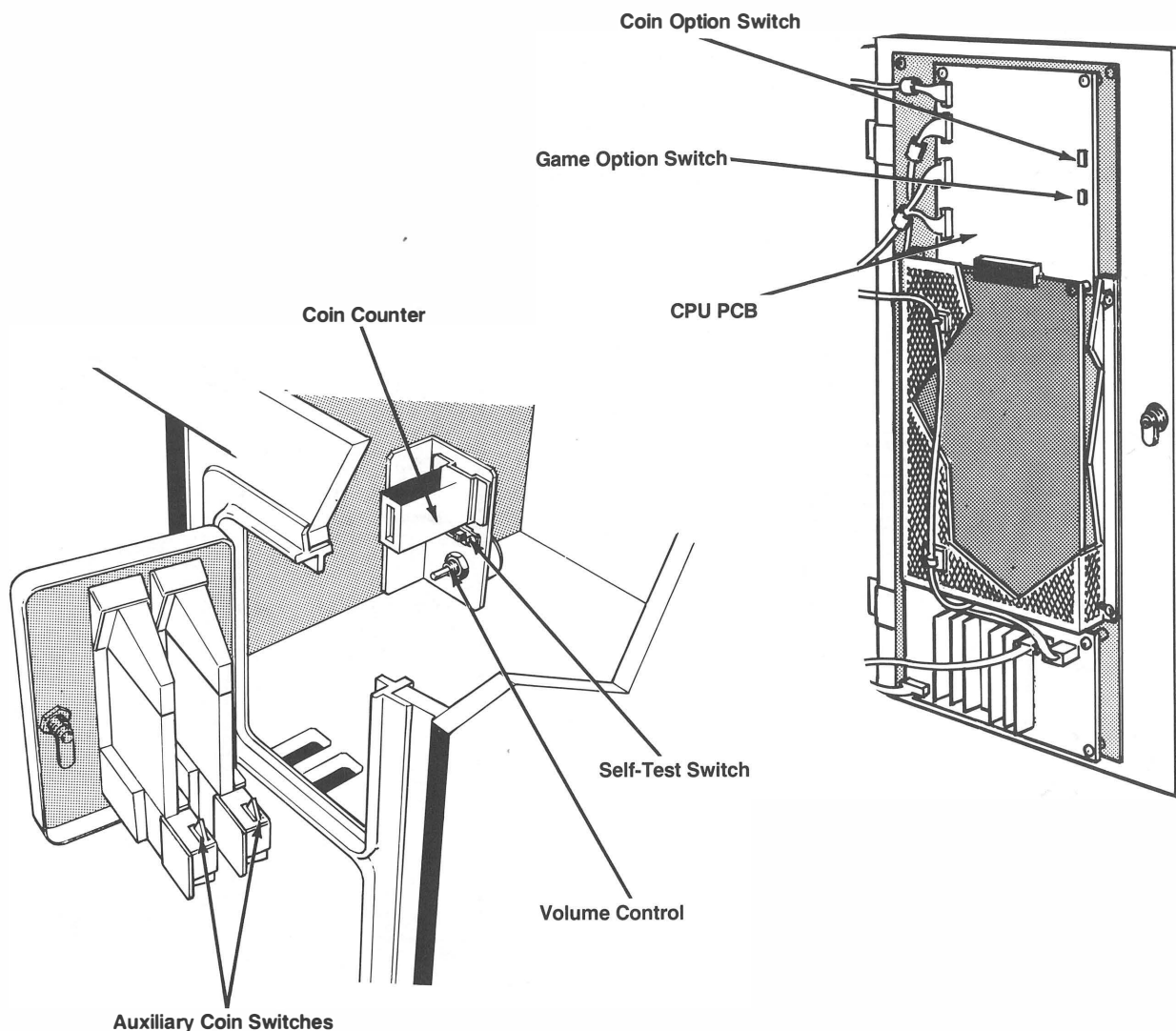

Figure 1-2 Control and Switch Locations

Settings for the PAPERBOY coin and game options are listed in Tables 1-2 and 1-3. Options preset at the factory are shown by the ◀ symbol; however, you may change the settings according to your needs. To verify the option selections, check the Switch Setting screen obtained in the Self-Test Mode as described in Chapter 2.

Operating Modes

There are four operating modes for the PAPERBOY game: Attract, Play, High-Score, and Self-Test.

Attract Mode

The Attract Mode begins either when the game is plugged in or after exiting the Play, High-Score, or Self-Test Modes.

The Attract Mode ends when the correct amount of coins or tokens are inserted and the one- or two-player start (throw) button on the handlebar control is pressed, or when the self-test switch is turned off. The Attract Mode continuously cycles through the following events:

- **Title Page**—A newspaper page is displayed with the title *PAPERBOY* and assorted headlines. In the center of the page is a picture of the PAPERBOY. The top three scorers in the Grand Slam table are shown under the titles *X.X.X. CHOSEN PAPERBOY OF THE MONTH* and *X.X.X., X.X.X. EARN RUNNER UP AWARDS*.
- **High-Score Table**—The four High Score tables are displayed (Easy Street, Middle Road, Hard Way, and Grand Slam). Scores are highlighted to show the corresponding scores in the street High Score tables and in the Grand Slam table.

Table 1-2 Coin and Credit Settings

Settings of 8-Toggle Switch on Paperboy CPU PCB (at 6/7A)										
1	2	3	4	5	6	7	8	Option		
								Coins Per Credit		
							Off	Off	1 Coin 1 Credit	
							Off	On	2 Coins 1 Credit ◀	
							On	Off	3 Coins 1 Credit	
							On	On	4 Coins 1 Credit	
									Right Coin Mechanism	
							Off	Off	1 Coin Counts as 1 Coin ◀	
							Off	On	1 Coin Counts as 4 Coins	
							On	Off	1 Coin Counts as 5 Coins	
							On	On	1 Coin Counts as 6 Coins	
									Left Coin Mechanism	
							Off		1 Coin Counts as 1 Coin ◀	
							On		1 Coin Counts as 2 Coins	
									Bonus Adder	
							Off	Off	Off	No Bonus Adder ◀
							Off	Off	On	2 Coins Give 1 Extra Coin
							Off	On	Off	4 Coins Give 1 Extra Coin
							Off	On	On	4 Coins Give 2 Extra Coins
							On	Off	Off	5 Coins Give 1 Extra Coin
							On	Off	On	3 Coins Give 1 Extra Coin
							On	On	On	Free Play

◀ *Manufacturer's recommended settings for American-made games.*

Table 1-3 Game Option Settings

Settings of 8-Toggle Switch on Paperboy CPU PCB (at 5/6A)									
1	2	3	4	5	6	7	8	Option	
								Difficulty	
							Off	Off	Medium Hard ◀
							Off	On	Easy
							On	Off	Medium
							On	On	Hard
									Bonus Life Given at:
							Off	Off	15,000 points ◀
							Off	On	No bonus life
							On	Off	10,000 points
							On	On	20,000 points
									Starting Lives
							Off	Off	4 ◀
							Off	On	Demonstration mode (unlimited number of lives)
							On	Off	3
							On	On	5

◀ *Manufacturer's recommended settings.*

- **Demo Mode**—The PAPERBOY is shown riding down the street delivering papers to customers, picking up papers, damaging non-customer houses, and jumping into a hearse. As the PAPERBOY performs these actions, an appropriate message is displayed at the bottom of the screen.

During the Attract Mode, if a whole new credit (not partial credits) is entered into the game through the coin mechanisms or the auxiliary coin switch, a gong sound is

played. The credit status and current coin mode are constantly displayed and updated throughout the Attract Mode.

Play Mode

Play mode begins when the correct credit is entered and the player 1 or 2 start button is pressed. Refer to *Game Play* for playing information.

High-Score Mode

Upon completion of a game, and if the player's score is among the top ten scores recorded in the game, the player has 30 seconds to enter his/her initials in the appropriate street High-Score table. Select initials by moving the handlebar control up or down and pressing either player-start (throw) button when the proper initial is displayed. Players can correct their initials by selecting the back arrow and pressing a player-start (throw) button. Then repeat the procedure for entering initials.

A separate High-Score table is displayed for each street. In addition, a Grand Slam table is displayed. The Grand Slam table takes the highest score from each street High-Score table for the same player and adds them together; then, if applicable, the second-highest score, the third-highest score, etc., for each street is added together. If these cumulative scores rank in the top ten scores recorded from each of the street High Score tables, they may appear in the Grand Slam table in their appropriately ranked position. This feature encourages players to try their hand at all streets.

Self-Test Mode

The Self-Test Mode can be entered from the Play Mode or from power-on. Turning the self-test switch on during the Play Mode will display the Accounting Information screen. Turning the self-test switch on after power-on will display the RAM/Interrupt/ROM Test screen. The Self-Test Mode provides data to demonstrate that the game circuitry, display, speakers, and handlebar control are working properly. See Chapter 2 for detailed information.

Game Play

PAPERBOY is a one- or two-player (alternating) game with a medium-resolution color raster video display. The handlebar control maneuvers the PAPERBOY through his paper route. Press either button on the handlebar control to throw papers. Your main objective is to deliver papers to your customers from Monday through Sunday, eventually completing an entire week of delivery. Successfully completing an entire week of deliveries concludes the game.

You begin the game with ten customers and ten non-customers. Your customers live in the brightly colored houses; non-customers live in dark colored houses. To deliver to a customer, you must throw a paper either on their porch or into their mailbox. Failure to deliver a paper to a customer results in the loss of that customer on the next day. Any damage done to a customer's property also results in the loss of that customer. Losing all ten of your customers will get you fired and your game is over. However, each time you deliver to *all* your customers you will receive a Perfect Delivery Bonus for that day. And, if

you have previously lost any of your ten customers, you will get one of them back as a re-subscriber.

Non-customers' houses and yards are loaded with targets at which to throw your extra papers (windows, lamps, statues, etc.). Upon hitting any of these targets, its respective point value goes into the Breakage Bonus, which is displayed at the top center of the screen. The Breakage Bonus is awarded to the player at the end of each day (or at the end of the game—whichever comes first).

If you lose a customer, that customer's house will be dark colored the next day. As a non-subscriber, this house now presents more targets at which to throw for building up your Breakage Bonus.

PAPERBOY can carry a maximum of ten papers at a time, but can restock his supply by riding over paper bundles placed here and there on his route. A paper supply indicator is displayed underneath the player's score.

While riding down the street, PAPERBOY must avoid collisions with all stationary objects and other characters moving about the neighborhood. To avoid collisions, PAPERBOY can ride his bike anywhere—on the sidewalk, in the street, or into front yards. A collision with anything results in the loss of a life.

The large cast of colorful characters make it increasingly more difficult for PAPERBOY to make his way down the street. Eventually, the player must develop great skill in maneuvering PAPERBOY to avoid street traffic, dogs, cats, various pedestrians, etc. In addition, many of the houses have certain characters associated with them. Non-subscribers are hostile to PAPERBOY and will attack him and try to knock him down. If you damage a subscriber's property, that character may also attack. So the more customers you lose, the more hostile the neighborhood gets toward PAPERBOY, and the tougher it becomes to avoid all the characters that are out to get PAPERBOY.

At the end of each delivery day, you have a chance to sharpen your skills by guiding PAPERBOY through the PAPERBOY Training Grounds. This obstacle course is filled with various targets at which to throw and jumps to make. You can't lose lives in this bonus round—any collision just ends the training course segment, after which you move on to the next delivery day. You must move fast through this course and try to cross the finish line before the time at the top of the screen runs out.

At the start of each day, a map of your route is displayed to indicate subscriber and non-subscriber houses. This map is helpful in reminding you of what customers you may have lost on the previous day and the location of your remaining customers.

Select a Street. At the start of each game, you will be presented with a chance to choose your paper route—Easy Street, Middle Road, or Hard Way. Each of these streets has distinctly different house designs and character appearance. Also, each street differs in its aggressiveness (scores are doubled on Middle Road, tripled on Hard

Way) and has a unique training course at the end of each day.

You will find that the different streets require different skill levels. One may call for a good deal of throwing accuracy, another lots of tricky maneuvering, and the third a combination of all skills. It's really three games in one.

Hints For Game Play

- Be careful not to move too slowly—swarms of bees or nasty whirlwinds may come to push you along.
- Develop skill in maneuvering in and out of tight situations using the handlebar control.
- Build up your Breakage Bonus by riding over flowers in non-subscribers' yards.
- Some players prefer to lose many of their customers so they can do more "trashing." Others like to try for Perfect Deliveries. See which strategy scores highest for you.
- Try hitting characters with papers—you might be pleased with the results!
- Dirt piles in the streets can be used for making jumps, which will also score points.

Operator Hints

Here are some pointers for maximizing earnings from your System II PAPERBOY game.

Game Difficulty

The key to maximum earnings is to strike a mid-point on game times. Game times must be short enough so that player turnover is high, but at the same time, they must be long enough to give the player good value and ensure repeated play—which is crucial to longevity. PAPERBOY gives the operator the flexibility to adjust game difficulty, and enough statistics to make intelligent adjustments.

Use the Self-Test Mode (see Chapter 2) to check the Accounting Information screen for game-time statistics; then, if desired, use the Switch Setting screen to make option changes. If collections seem low or are dropping off, observe game times on the Accounting Information screen. If most game times are under 120 seconds, change the game difficulty option to an easier setting. If most game times are over 180 seconds, change game difficulty to a harder setting.



Game Sounds

Your System II cabinet with the PAPERBOY game uses more effective audio than previous games, which results in more player involvement and enjoyment. The System II games use advanced digital sound-generation techniques to create realistic musical instrument sounds (such as clarinets, harmonicas, drums, and violins). Although a player may not be consciously aware of the music, it has a direct effect on the excitement and emotional experience of the game.

The PAPERBOY game creates ear-catching sound effects, which are designed to give feedback to make the player believe that the game is responding directly to his actions. To maximize the player's enjoyment of this enhanced audio and maximize your earnings, consider the following hints:

1. The game location should be a relatively dead acoustical environment. The goal is to minimize unnecessary sound reflection, so that the sounds from the PAPERBOY game won't be drowned out by the accumulation of other sounds that bounce around the room. Carpets help eliminate sound reflections from the floor. Acoustical tile is also useful, especially if you have low ceilings.
2. If you use an environmental sound system or a stereo, consider lowering its volume or perhaps even turning it off. In the days when video games just made harsh beeps and boops, a central sound system helped make up for the lack of drive and excitement in a game's sounds. But your PAPERBOY game is very musical, and a sound system interferes with the game's ability to interest players and draw bystanders.
3. Be concerned with the overall volume levels in arcade environments. The goal is to involve the players' emotions, not to damage their hearing. To a certain point, raising the game volume helps add to player excitement, but above that level it creates hearing fatigue and the high volume starts to drive players away. Rather than turning up the volume on the PAPERBOY games to cut through the background sound level, try lowering the volume of any neighboring games that have sounds which are not an attractive or important element. Careful placement of games and attention to unnecessary noise sources can also help increase the player's sense of game involvement and interaction.

N O T E S

Self-Test

This game will test itself and provide visual and audible indications of the condition of the game circuitry and controls. Self-test information is visually displayed on the screen and audibly presented through the sound system. No additional equipment is required.

We suggest that you perform a self-test when you first set up the game, each time you collect the money, or when you suspect game failure. Coin and game options are selected in the Self-Test Mode.



After the self-test switch is set to the on position, twelve self-test screens provide a visual and audible check of the Paperboy game circuits. Refer to Chapter 1 in this manual (TM-275) for the location of the self-test switch.

The Self-Test Mode can be entered immediately after turning on the game power, either from the Play Mode or from the Attract Mode. If the self-test switch is turned on during the Play or the Attract Mode, the first display to appear is Accounting Information. By pressing the right-hand throw button the self-test will then advance to the next screen, Switch Settings, and back to the 6502 Processor Test. The self-test will then advance from the 6502 Processor Test to the end. The game power must be turned off, the self-test switch turned on, and the game power turned on again to start the self-test with the RAM/Interrupt/ROM Test.

The following self-test procedure is presented in the sequence in which the self-test screens appear when the self-test switch is turned on and *then* the game power is turned on. Turning the self-test switch off at any time during the self-test causes the game to return to the Attract Mode.

RAM/Interrupt/ROM Test

The RAM/Interrupt/ROM Test screen displays failure information for the RAM, interrupt, and program ROM circuitry on the CPU and Video PCBs. If the RAM/Interrupt/ROM test passes, the display will advance to the 6502 Processor Test.

The RAM test checks the condition of the T-11 microprocessor RAM, zero page RAM, motion object RAM, playfield RAM, alphanumeric RAM, and associated circuitry located on the Video PCB. If the RAM test fails, an error message gives the location of the failed RAM or associated circuitry on the Video PCB as shown in Figure 2-1.

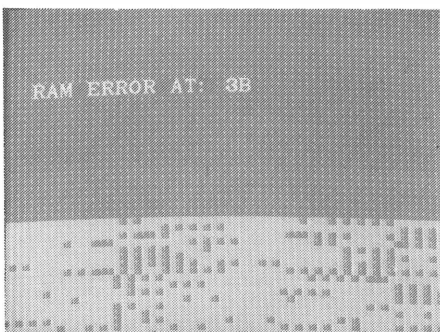

Figure 2-1 RAM Test Fails

If the zero-page RAM or associated circuitry fails, the screen turns red and the address of the failed component's location flashes continuously to facilitate troubleshooting.

After the RAM test passes, the interrupts on the CPU and Video PCB are checked. If the interrupt test fails, an error message (as shown in Figure 2-2) may appear on a green

screen, which indicates a possible vertical-blanking or interrupt-logic failure.

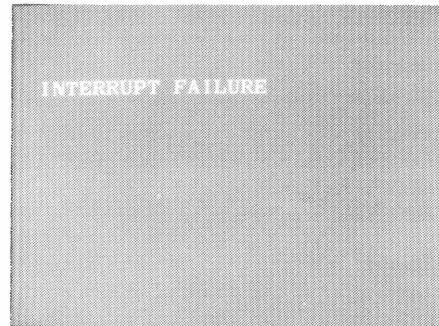

Figure 2-2 Interrupt Test Fails

After the interrupt test passes, all ten of the program ROMs on the CPU PCB are tested for checksums. If the ROM test fails, an error message gives the location of the failed ROM or associated circuitry (as shown in Figure 3).

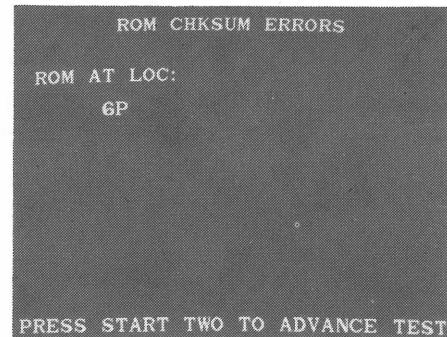

Figure 2-3 ROM Test Fails

6502 Processor Test

The 6502 Processor Test screen provides visual and audible information to check the condition of the 6502 sound microprocessor and associated circuitry. All functions of the sound microprocessor are checked including: RAM/ROM, interrupts, music synthesizer, sound-effects processor, and speech synthesizer. Basic communication between the T-11 (master) and the 6502 (slave) microprocessors is also checked.

NOTE

Press the right-hand throw button at any time during the 6502 processor test to advance to the Control Test.

The 6502 test starts with a reset/communications check that first resets the 6502 and then checks for proper response to start up protocol. This test checks the communications ports (T-11 to 6502 and 6502 to T-11), the 6502 reset circuit, and the general condition of the 6502.

If the 6502 circuitry does not respond properly to the reset, the system will retry the reset procedure ten times, then an error message and retry count number is displayed (as shown in Figure 2-4).

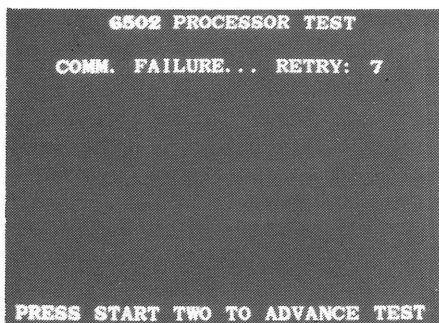

Figure 2-4 Reset Retry

If the 6502 circuitry fails to reset through all ten attempts, a communications error message will be displayed (as shown in Figure 2-5).

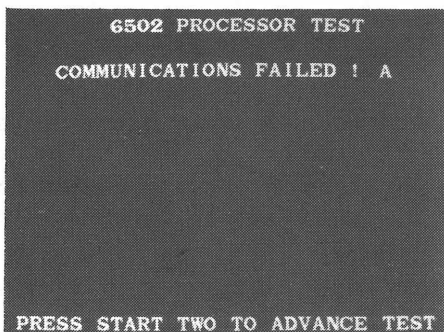

Figure 2-5 Communications Fails

If the reset/communications check passes, then the condition of the 6502 microprocessor, RAM, ROM, interrupts, music (Yamaha) synthesizer, and associated circuitry is checked. If one or more of these circuits fails, an error message is displayed (as shown in Figure 2-6).

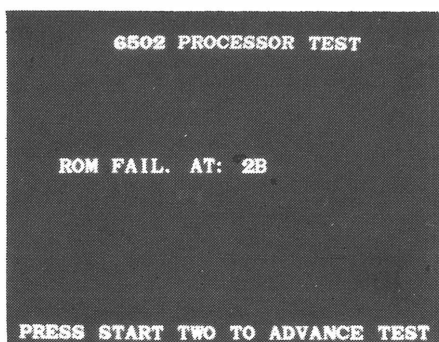

Figure 2-6 Music/RAM/ROM Fails

If the RAM, ROM, and music synthesizer check passes, then the music (Yamaha) synthesizer, sound-effects

(POKEY) generator, and speech synthesizer sound outputs are checked. As each of these four tests is run, an appropriate message is displayed (as shown in Figure 2-7).

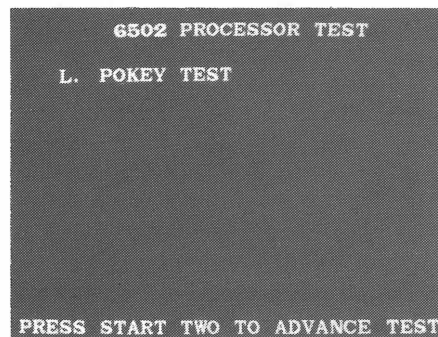

Figure 2-7 Sound Output

- *YAMAHA TEST* consists of eight tones in a major scale that alternate between left and right sound channels (16 tones total).
- *L. POKEY TEST* consists of four tones in a major chord that come from the left sound channel.
- *R. POKEY TEST* consists of four tones in a major chord that come from the right sound channel.
- *SPEECH TEST* consists of the phrase: "Now you have a friend in the paper business." The phrase should be clear and understandable.

After the four sound output tests are completed, the sound status messages are displayed (as shown in Figure 2-8).

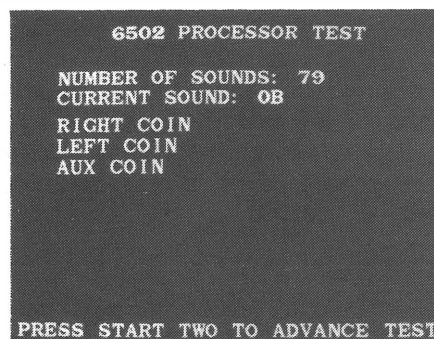

Figure 2-8 Sound Status

- *NUMBER OF SOUNDS* is the total number of sounds used in the Paperboy game.
- *CURRENT SOUND* is the current sound selected for playing.

Press the left-hand throw button to select the sound numbers indicated by the *CURRENT SOUND* message shown in Figure 2-8. Move the handle-bar control forward and backward to sequence through the selected sounds.

The sound status screen also displays the condition of the left, right, and auxiliary coin switches. Press the left and right coin switches (see Figure 2-2 in Chapter 1 for switch locations) and check the display for a corresponding *LEFT COIN* and *RIGHT COIN* message. Press the auxiliary (aux) coin switch (see Figure 1-2 in Chapter 1 of this manual for switch location), and check the display for a corresponding *AUX COIN* message.

Press the right-hand throw button to obtain the next test.

Control Test

The Control Test screen displays the condition of the horizontal and vertical potentiometers, A/D converter, left-hand throw switch, and associated circuitry. (It is assumed that the right-hand throw switch works because it was used to advance to this test.) The Control Test screen is also used to calibrate the handlebar control horizontal and vertical potentiometers.

Press the left-hand throw button to obtain the Control Test screen shown in Figure 2-9.

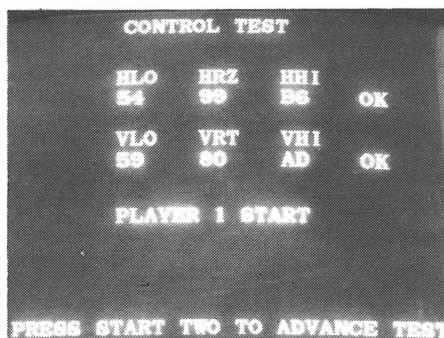

Figure 2-9 Control Test Passes

If the range of the horizontal and vertical potentiometers on the handlebar control (horizontal low to horizontal high and vertical low to vertical high) is large enough, then the message *OK* is displayed next to the appropriate control range reading. If the range is too small, then the message *BAD* is displayed.

Calibration Procedure

The handlebar control is calibrated at the factory and should recalibrate itself during game play. However, if the control does not respond correctly, calibrate as follows:

1. Press and hold down the left throw button. Press and release the right throw button.
2. Turn the handlebar control to the extreme left, right, up, and down positions. Check the display: the control range should read *OK*.
3. If the problem still persists, check the physical alignment of the vertical and horizontal potentiometers as

described under *Aligning the Handlebar Control Potentiometers* in Chapter 3 of this manual.

Press the right-hand throw button to set the vertical and horizontal potentiometer calibration and obtain the next test.

Alphanumeric Test

The Alphanumeric Test screen displays the condition of the alphanumeric ROM, alphanumeric color palettes, and associated circuitry (as shown in Figure 2-10).

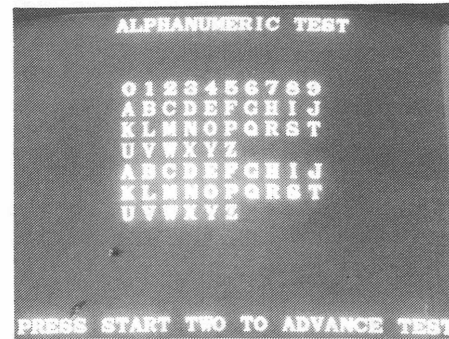

Figure 2-10 Alphanumeric Test

The displayed alphanumeric characters should be repeated twice with the first set yellow and the second set blue with red specks. If first set of characters is yellow and the second set is **not** blue, then there may be a problem with the color palette select circuits.

Press the right-hand throw button to obtain the next test.

Scrolling Playfield Test

The Scrolling Playfield Test checks the condition of the playfield ROM, playfield display circuits, and playfield color palettes. The Scrolling Playfield Test screen appears as shown in Figure 2-11.

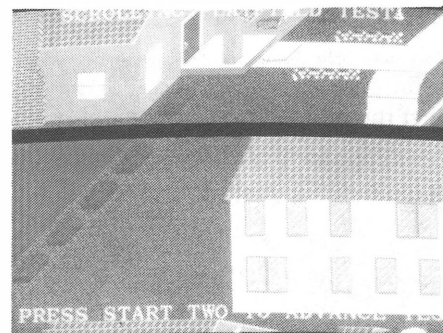

Figure 2-11 Scrolling Playfield Test

The display in Figure 2-11 shows a street scene with two houses. The first house should be orange and the second

house blue. The entire playfield RAM is used for this display, except four rows that make up the black border on top of the screen. Move the handlebar control up, down, right, and left; note that the display scrolls correspondingly.

Press the right-hand throw button to obtain the next test.

Motion Object Test

The first Motion Object Test checks the motion object horizontal and vertical display locations, motion-object color palettes, and the motion/playfield prioritizing logic circuit. The first Motion Object Test screen appears as shown in Figure 2-12.

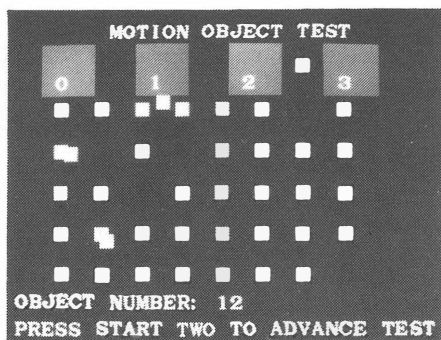

Figure 2-12 Motion Object Test

The Motion Object Test screen should show 39 motion objects and four colored boxes (numbered 0 through 3). The left two boxes (0 and 1) should be red and the right two boxes (2 and 3) should be green. The motion objects should be colored (from left to right) blue, light blue, purple, and white. Any error in color may indicate a problem with the color palette select circuits.

Move the handlebar control and note that the currently displayed motion object moves correspondingly. Move the motion object across the four colored boxes. Note that the motion object moves *behind* the red boxes and *in front of* the green boxes. Press the left-hand throw button to select the next motion object and repeat the preceding procedure. This procedure checks the prioritizing logic circuitry.

Press the right-hand throw button to obtain the next test.

Motion Object Height Test

The Motion Object Height Test checks the motion object height circuit and the horizontal load disable circuit. The Motion Object Height Test screen appears as shown in Figure 2-13.

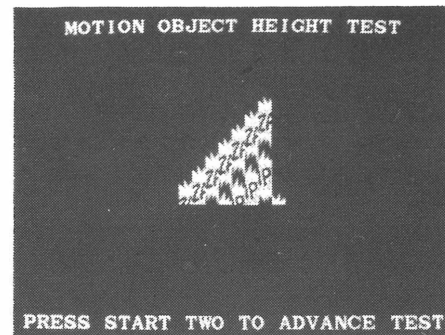

Figure 2-13 Motion Object Height Test

Each successive column of motion objects should be 16 pixels taller than the last. The top 16 pixels of each column should be the same. Each column should add a new 16 × 16 pixel stamp picture to the bottom and slide the previous one up by 16 pixels. Move the handlebar control to move the entire picture around on the screen. Press the left-hand throw button to obtain a new set of motion objects.

Press the right-hand throw button to obtain the next test.

Color Bar Test

The Color Bar Test checks the condition of the color RAM, video amplifiers, and associated circuitry. The Color Bar Test screen appears as shown in Figure 2-14.

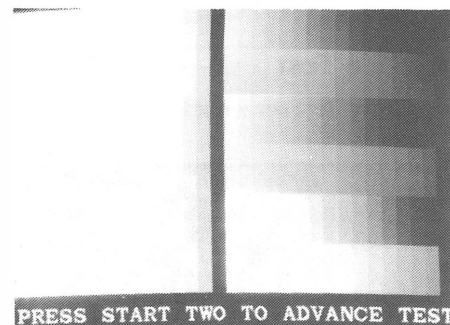

Figure 2-14 Color Bar Test

Sixteen vertical grey-scale bars and three groups of sixteen vertical bars with shades of red, green, or blue are displayed. The brightest bar should be on the left and darkest (black) bar on the right, with a black frame around the screen. Each group of red, green, or blue should be split in half horizontally to show two fade scales. Each upper fade scale is ranged by changes in overall intensity (Z) and each lower fade scale by individual color intensity (R, G, B). This test helps to determine if white tracking is set properly (grey-scale bars range from white to grey). Refer to the white tracking procedure in the display manual if adjustment is required.

Press the right-hand throw button to obtain the next test.

Color Purity Test

Color Purity Test consists of five color displays that check the condition of the display color-purity circuits. The first display to appear should be a red screen with the word *RED* displayed at the bottom of the screen as shown in Figure 2-15.



Figure 2-15 Color Purity Test

Press the left-hand throw button; the next display to appear should be a green screen with the word *GREEN* displayed at the bottom. Press the left-hand throw button to obtain a blue, white, and finally a grey screen. After that, the display will return to the red screen.

If the display characteristics are not correct, refer to the display manual for the color-purity adjustment procedure or the possible cause of failure.

Press the right-hand throw button to obtain the next test.

Convergence Test

The Convergence Test screen appears as shown in Figure 2-16.

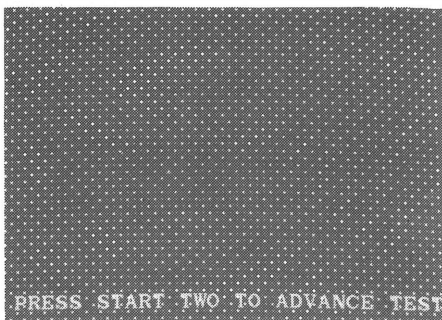

Figure 2-16 Convergence Test

A violet dot pattern displays the red-to-blue convergence. Press the left-hand throw button to obtain a white-dot convergence pattern. Convergence between any two colors should not exceed 0.7 mm in the middle of the screen and 1.2 mm in the corners. This pattern may also be used to set up screen size, centering, and brightness (black level).

Press the right-hand throw button to obtain the next screen.

Accounting Information

The Accounting Information screen provides useful statistics about the game (as shown in Figure 2-17).

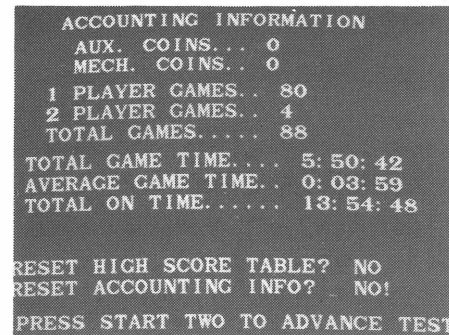

Figure 2-17 Accounting Information

The following game statistics appear on the Accounting Information screen:

- *AUX COIN* shows the number of coins entered through the auxiliary coin switch.
- *MECH COIN* shows the total number of coins deposited in the left and right coin mechanisms.
- *1 PLAYER GAMES* shows the number of 1-player games played.
- *2 PLAYER GAMES* shows the number of 2-player games played.
- *TOTAL GAMES* shows the total of the 1- and 2-player games played (each 2-player game is counted as two games).
- *TOTAL GAME TIME* shows the accumulated time of all the games played in hours, minutes, and seconds.
- *AVERAGE GAME TIME* shows the total game time divided by the total number of games in hours, minutes, and seconds.
- *TOTAL ON TIME* shows the total time in hours, minutes, and seconds that the game has been turned on (percent usage = total game time/total on time).

The game statistics are accumulated from the first time the game is turned on or from the last time the statistics were reset. This screen is also used to reset the game statistics and the high-score table.

Resetting the Game Statistics. Reset the game statistics as follows:

1. Pull the handlebar control downward to position the exclamation mark (!) next to the *Reset Accounting Information* message.
2. Press the left-hand throw button to change the *NO* message to *YES*.

The game statistics are reset after the right-hand throw button is pressed to leave the Accounting Information screen.

Resetting the High-Score Table. Reset the High-Score Table as follows:

1. Pull the handlebar control upward to position the exclamation mark (!) next to the *Reset High-Score Table* message.
2. Press the left-hand throw button to change the *NO* message to *YES*.

The High-Score Table is reset after the right-hand throw button is pressed to leave the Accounting Information screen.

Press the right-hand throw button to obtain the next screen.

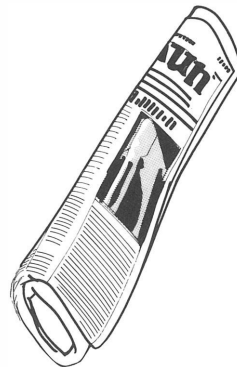

Switch Settings

The Switch Settings screen displays the coin and game option settings of the two dual-in-line package switches at locations 6/7A and 5/6A on the CPU PCB. The Switch Settings screen appears as shown in Figure 2-18. Refer to Chapter 1 for detailed coin and game option setting information.

```

SWITCH SETTINGS
CREDIT MODE...
  2 COINS 1 CREDIT
RIGHT MECH. MULTIPLIER...
  1 COIN COUNTS AS 1 COIN
LEFT MECH. MULTIPLIER...
  1 COIN COUNTS AS 1 COIN

NO BONUS ADDER

OPTION SWITCH SETTINGS...
DIFFICULTY: MED. HARD
BONUS LIFE: 15,000
NUMBER OF LIVES: 4
PRESS START TWO TO ADVANCE TEST
  
```

Figure 2-18 Switch Settings

Press the right-hand throw button to obtain the 6502 Processor Test or turn the self-test switch off to select the Attract Mode.



N O T E S

Maintenance

This chapter includes preventive and corrective maintenance procedures for the PAPERBOY game components that are subject to the most use. To assure maximum trouble-free operation from this game, we recommend that preventive maintenance be performed as described in this chapter.

Removal, disassembly, reassembly, and replacement procedures are provided for components that may require corrective maintenance. Appropriate references are provided to Chapter 5 Illustrated Parts Lists, to aid in locating the parts of this game that are mentioned, but not illustrated, in the maintenance procedures.

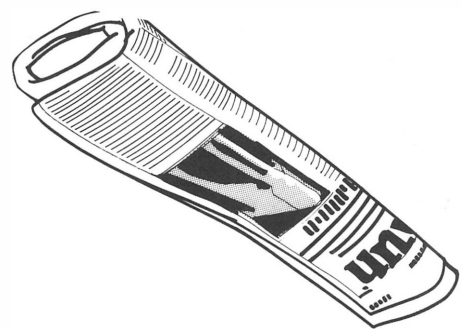
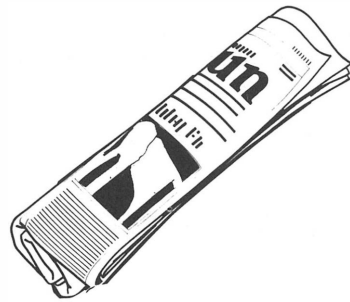

Preventive Maintenance

Preventive maintenance includes cleaning, lubricating, and tightening hardware. How often preventive maintenance is performed depends upon the game environment and frequency of play. However, for those components listed in *Table 3-1 Preventive-Maintenance Intervals*, we recommend that preventive maintenance be performed at the intervals specified.

Preventive-Maintenance Intervals

The preventive-maintenance intervals specified are as follows:

- **Handlebar Control.** Lubricate and tighten hardware at least every three months.
- **Coin Mechanism.** Clean at least every three months.

⚠ WARNING ⚠

To avoid possible electrical shock, turn off and unplug the game before performing any maintenance procedures.

Removing the Control Panel

Perform the following procedure to remove/replace the control panel (see Figure 3-1).

1. Use a 1/8-inch hex driver to loosen the two screws securing the lower retainer to the cabinet.
2. Unlock and open the coin door on the front of the cabinet.
3. Carefully reach up through the coin door opening and release the spring-draw latches located under the control panel on both sides of the cabinet.
4. Use a 1/8-inch hex driver to remove the two screws and washers securing the front of the control panel to the cabinet.
5. Grasp the handlebar control and gently lift until the bottom edge of the control panel clears the cabinet.
6. Carefully slide the top edge of the control panel from under the lower retainer.

7. Lift the control panel from the cabinet just far enough to expose the control-panel harness connector.
8. Disconnect the handlebar control-harness connector and remove the control panel from the cabinet.
9. Replace the control panel in the reverse order of removal.

Lubricating and Tightening the Handlebar Control

Perform the following procedure to lubricate and tighten the handlebar control. Lubrication can be performed without removing the handlebar control assembly from the control panel. See Figures 3-7, 3-8, and 3-9 for the location of the lubrication points and parts mentioned in the following procedure.

1. Remove the control panel as previously described.
2. Use a Phillips screwdriver to remove the four screws that hold the U-shaped cover to the accelerator unit.
3. Lift the cover from the accelerator unit and lubricate the following parts inside the handlebar control (see the oil-can symbols in Figures 3-7, 3-8, and 3-9).
 - a. Apply two drops of light machine oil (Atari part no. 107013-001) to the potentiometer shafts and to the four main axle bearings.
 - b. Brush a light film of Nyogel 779 lubricant (Atari part no. 178027-001) over the outside of the four torsion springs and on the teeth of the two small spur gears.
4. Use a 1/2-inch, a 5/16-inch, and a 7/16-inch wrench to tighten the potentiometer-mounting nuts, anchor nuts, and handlebar control mounting nuts, respectively.
5. Use a 7/64-inch hex driver to tighten the potentiometer cap screws.
6. Reinstall the U-shaped cover and replace the control panel in the reverse order of removal. Make sure the spring-draw latches are locked in position.

Cleaning the Coin Mechanism

Use a soft-bristled brush to remove loose dust or foreign material from the coin mechanism. A toothbrush may be used to remove any stubborn build-up of residue in the

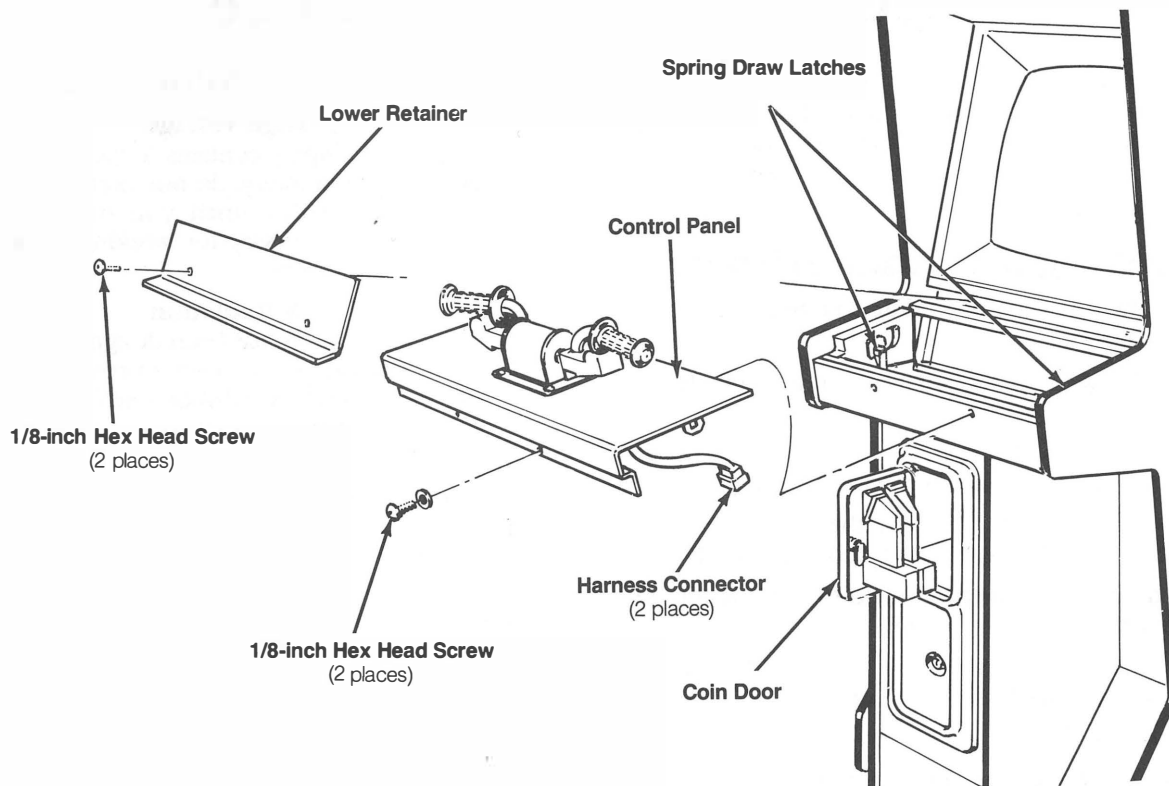

Figure 3-1 Control Panel Removal

coin path. After cleaning the coin mechanism, blow out all of the dust with compressed air.

Cleaning the Interior Components

Perform the following procedure to clean the components inside the cabinet.

⚠ WARNING ⚠

Turn off the game power, but do not unplug the power cord before cleaning inside the cabinet. The power cord provides a ground path for stray static voltages that may be present on the cleaning tools.

- a. Attach one end of a large, well-insulated, 18-gauge jumper wire to ground.
- b. Momentarily touch the free end of the grounded jumper to the CRT anode by sliding it under the anode cap.
- c. Wait two minutes and repeat part b.

CAUTION

Be extremely careful when cleaning the electrical components inside the cabinet. Avoid touching the electrical components with any solid object other than the soft bristles of the vacuum attachment or paint brush.

1. Unlock and open the rear access door.
2. Discharge the high-voltage from the cathode-ray tube (CRT) before proceeding. The display assembly contains a circuit for discharging the high voltage to ground when power is removed. However, to make certain, always discharge the display as follows.
3. Use a vacuum cleaner with a soft long-bristled brush attachment or use a soft-bristled paint brush to remove loose dirt and dust accumulated on the inside of the cabinet. Be sure to clean the electrical components thoroughly (power supplies, PCB assemblies, display, etc.).

Corrective Maintenance

Corrective maintenance consists of removal, disassembly, reassembly, and replacement of game components. The following procedures are provided for components that may require corrective maintenance.

Removing the Video Display

Perform the following procedure to remove/replace the video display (see Figure 3-2).

1. Turn the game power off and wait two minutes. Unplug the power cord.
2. Use a 1/8-inch hex driver to remove the two screws securing the lower retainer to the cabinet.
3. Grasp the display shield on the bottom edge and gently pull it out about a half-inch from the cabinet.
4. Gently lower the display shield to free the top edge from under the speaker grille.
5. Use a flat-head screwdriver to remove the staples, if any, securing the bezel to the cabinet.
6. Remove the bezel.
7. Unlock and open the rear access door.

⚠ WARNING ⚠

High Voltage

The video display contains lethal high voltages. To avoid injury, do not attempt to service this display until you observe all precautions necessary for working on high-voltage equipment.

X-Radiation

The video display has been designed to minimize X-radiation. However, to avoid possible exposure to soft X-radiation, NEVER modify the high-voltage circuitry.

Implosion Hazard

The cathode-ray tube may implode if struck or dropped. Shattered glass may cause injury within a 6-foot radius. Use care when handling the display.

8. Discharge the high-voltage from the cathode-ray tube (CRT) before proceeding. The display assembly contains a circuit for discharging the high voltage to ground when power is removed. However, to make certain, always discharge the display as follows.
 - a. Attach one end of a large, well-insulated, 18-gauge jumper wire to ground.
 - b. Momentarily touch the free end of the grounded jumper to the CRT anode by sliding it under the anode cap.
 - c. Wait two minutes and repeat part b.

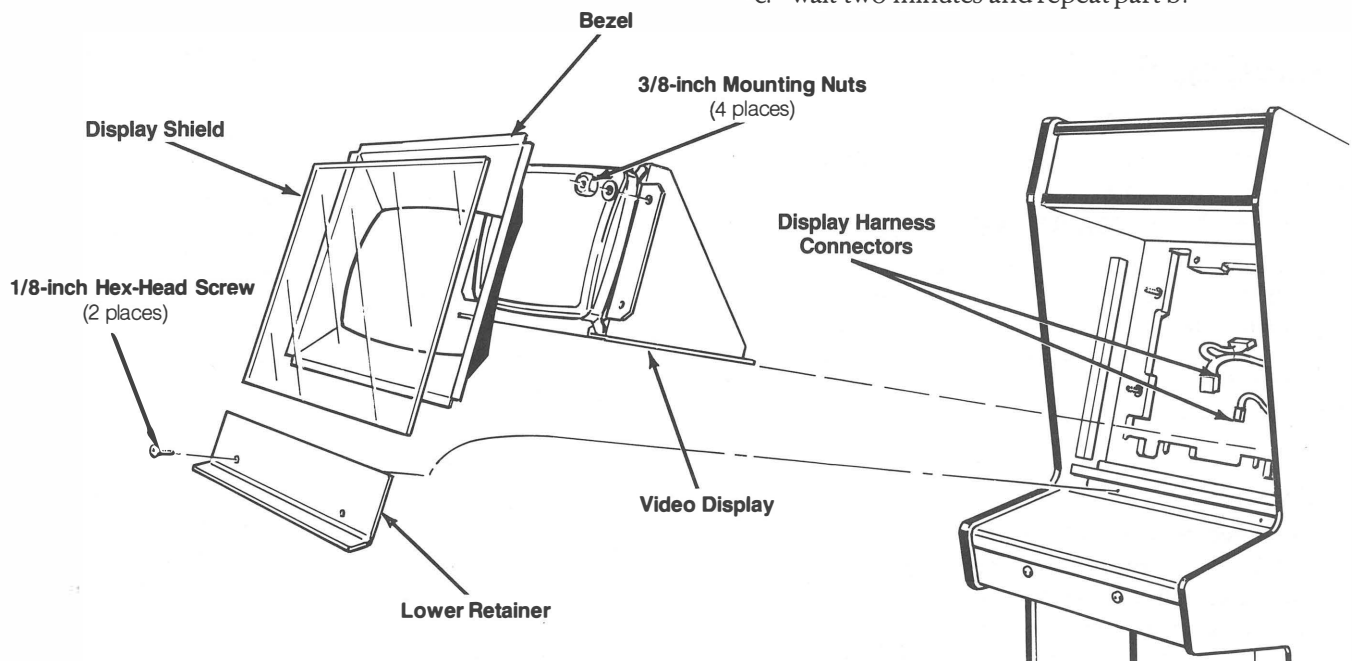

Figure 3-2 Video Display Removal

- From the back of the cabinet, unplug the display harness connectors and disconnect the green ground wire from the clip on the video display chassis.

⚠ WARNING ⚠

To avoid dropping the video display out of the game cabinet, use extreme care when removing the display-mounting nuts. We recommend that a second person *carefully* hold the display chassis from the back of the cabinet while the mounting nuts are being removed.

- From the front of the cabinet, use a 3/8-inch wrench to remove the four nuts and flat washers securing the display to the cabinet.
- Carefully slide the display out through the front of the cabinet.
- Replace the video display in the reverse order of removal.

NOTE

Whenever the cathode-ray tube is replaced, readjust the brightness, purity, and convergence as described in the display manual.

Removing the Game PCBs

Perform the following procedure(s) to remove/replace the game PCB(s).

CAUTION

Do not attempt to remove the CPU and Video PCBs while they are connected together. If you are going to remove both the Video and CPU PCBs, remove the Video PCB *first* to avoid damaging the PCBs or the edge connectors.

Video PCB

Perform the following procedure to remove/replace the Video PCB (see Figure 3-3).

- Turn the game power off.
- Unlock and open the rear access door.
- Use your fingers to remove the four thumb nuts securing the EMI shield to the ground plane.
- Disconnect the harness connector from the bottom of the Video PCB.
- Use a Phillips screwdriver to remove *one* of the two screws, washers, and spacers securing the top of the Video PCB (and bottom of the CPU PCB) to the ground plane. Loosen the other screw just enough so that it can be removed with your finger.

Video PCB (and bottom of the CPU PCB) to the ground plane. Loosen the other screw just enough so that it can be removed with your finger.

- Use a Phillips screwdriver to remove the two screws and washers securing the bottom of the Video PCB to the ground plane. Be careful to hold the Video PCB in place to prevent the PCB from falling or causing excessive bending at the edge connector.
- Remove the remaining screw, washer, and spacer that was loosened in step 5. Gently disconnect the Video PCB from the CPU PCB.
- Replace the Video PCB by first connecting the Video PCB to the CPU PCB edge connector. Carefully position both the Video and CPU PCBs so that the holes (in the bottom of the CPU PCB and at the top of the Video PCB) are aligned. Partially install one screw, with washer and spacer, through both of the PCBs and into the corresponding ground plane post.
- Install and tighten the two screws and washers securing the bottom of the CPU PCB to the ground plane.
- Install the remaining screw, washer, and spacer securing the top of the Video PCB (and bottom of the CPU PCB) to the ground plane.
- Tighten both screws securing the top of the Video PCB (and bottom of the CPU PCB) to the ground plane.
- Connect the harness connector to the bottom of the Video PCB.

CPU PCB

Perform the following procedure to remove/replace the Video PCB (see Figure 3-3).

NOTE

If the Video PCB has already been removed, use a Phillips screwdriver to remove the two screws and washers securing the top of the CPU PCB to the ground plane. Remove the CPU PCB.

- Turn the game power off.
- Unlock and open the rear access door.
- Use your fingers to remove the four thumb nuts securing the EMI shield to the ground plane.
- Disconnect the harness connectors from the left edge of the CPU PCB.
- Use a Phillips screwdriver to remove *one* of the two screws, washers, and spacers securing the bottom of the CPU PCB (and top of the Video PCB) to the ground plane. Loosen the other screw just enough so that it can be removed with your fingers.

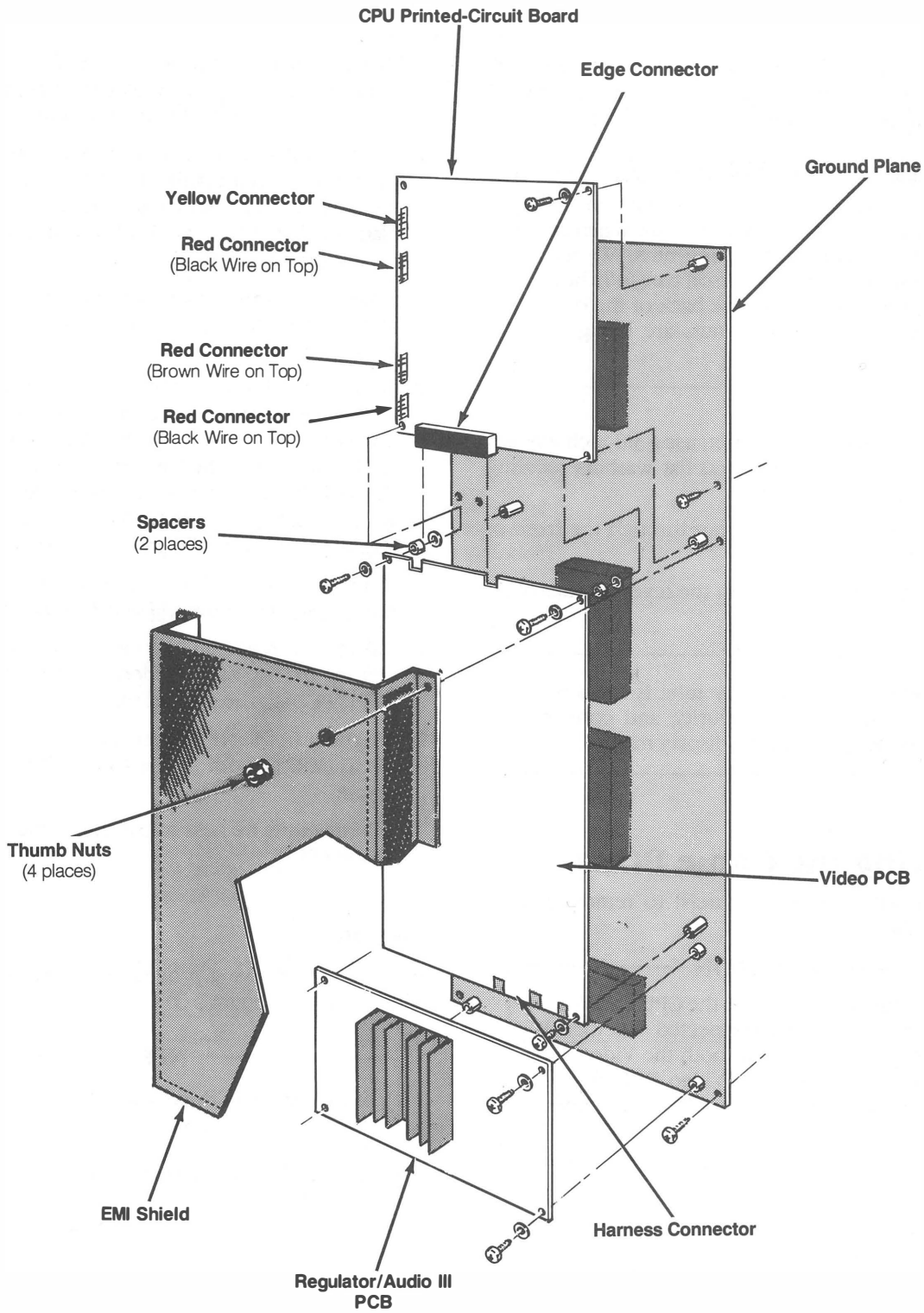

Figure 3-3 Game PCB Removal

plane. Loosen the other screw just enough so that it can be removed with your fingers.

6. Use a Phillips screwdriver to remove the two screws and washers securing the top of the Video PCB to the ground plane.

7. While holding the CPU PCB in place, remove the remaining screw, washer, and spacer that was loosened in step 5. Gently disconnect the CPU PCB from the Video PCB.
8. Replace the CPU PCB by first connecting the CPU PCB to the Video PCB edge connector. Carefully position both the CPU and Video PCBs so that the holes (in the bottom of the CPU PCB and at the top of the Video PCB) are aligned. Partially install one screw, washer, and spacer through both of the PCBs and into the corresponding ground plane post.
9. Install and tighten the two screws and washers securing the top of the Video PCB to the ground plane.
10. Install the remaining screw, washer, and spacer securing the bottom of the CPU PCB (and top of the Video PCB) to the ground plane.
11. Tighten both screws securing the bottom of the CPU PCB (and top of the Video PCB) to the ground plane.
12. Connect the harness connectors to the left edge of the CPU PCB. Refer to Figure 3-3 for the proper connector locations.

Removing the Fluorescent-Light Assembly

Perform the following procedure to remove/replace the fluorescent-light assembly (see Figure 3-4).

1. Turn the game power off.
2. From the front of the cabinet, use a 1/8-inch hex driver to remove the three screws and washers securing the upper retainer to the top of the cabinet.
3. Grasp the top edge of the attraction shield and film, then lift them out of the cabinet.
4. Disconnect the fluorescent-light harness connector.
5. To remove the fluorescent tube, gently twist the tube a quarter turn and remove it from the sockets. Replace in the reverse order.
6. To remove the entire fluorescent-light assembly, use a Phillips screwdriver to remove the two screws securing the fluorescent-light board to the cabinet. Lift the fluorescent-light assembly out of the front of the cabinet. Replace the fluorescent-light assembly in the reverse order of removal.

Removing the Speakers

Perform the following procedure to remove/replace the speakers (see Figure 3-5).

1. Use a 1/8-inch hex driver to remove the three screws securing the rear of the speaker grille to the cabinet.
2. Use a Phillips screwdriver to remove the three screws securing the front of the speaker grille to the cabinet.

3. Remove the speaker grille.

CAUTION

Do not touch the speaker cones when handling the speakers. The cone material is fragile and can be easily damaged.

4. Use a Phillips screwdriver to remove the four screws securing the speaker to the cabinet. Do not let the speaker fall.
5. Lower the speaker just far enough to disconnect the two speaker wires.
6. Replace the speaker in the reverse order of removal.

Disassembling the Handlebar Control

The following procedures apply to the handlebar control. The handlebar control consists of an accelerator unit and a steering unit. The accelerator unit controls the rate of vertical motion, and the steering unit controls the horizontal motion, of the graphics on the display. After any corrective maintenance is performed, the handlebar control should be recalibrated as described in this chapter under *Calibrating the Handlebar Control*.

Removing the Pushbutton Leaf Switches

Perform the following procedure to remove/replace the pushbutton leaf switches (see Figure 3-8).

1. Use a Phillips screwdriver to remove the three screws that hold the switch cover onto the handlebars.
2. Use a 15/16-inch wrench to remove the stamped nut that holds the switch to the handlebar frame.
3. Unsolder the two harness wires from the pushbutton leaf switch.
4. Replace the pushbutton leaf switches in the reverse order of removal.

Removing the Handlebar Assemblies

Perform the following procedure to remove/replace the handlebar assemblies (see Figure 3-8).

1. Use a Phillips screwdriver to remove the three screws that hold the switch cover onto the handlebar frame.
2. Use a 15/16-inch wrench to remove the stamped nut that holds the pushbutton leaf switch to the handlebar frame.
3. Unsolder the two harness wires from the pushbutton leaf switch.
4. Use a 3/16-inch punch to knock out the roll pin that holds the handlebar assembly onto the axle.
5. Gently slide the handlebar assembly from the axle.

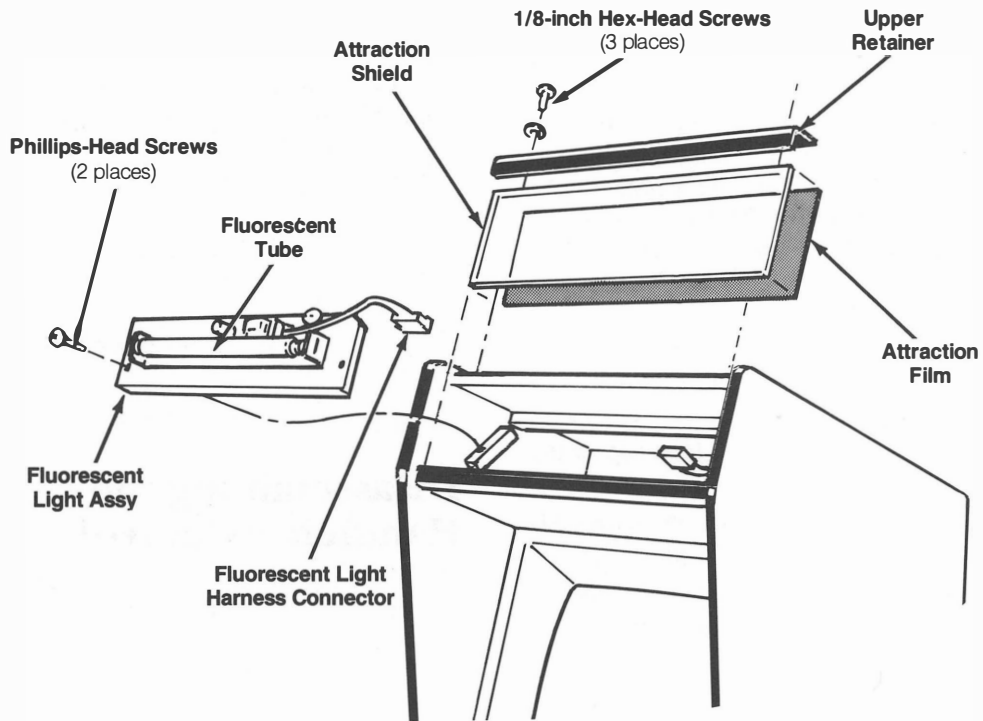

Figure 3-4 Fluorescent-Light Assembly Removal

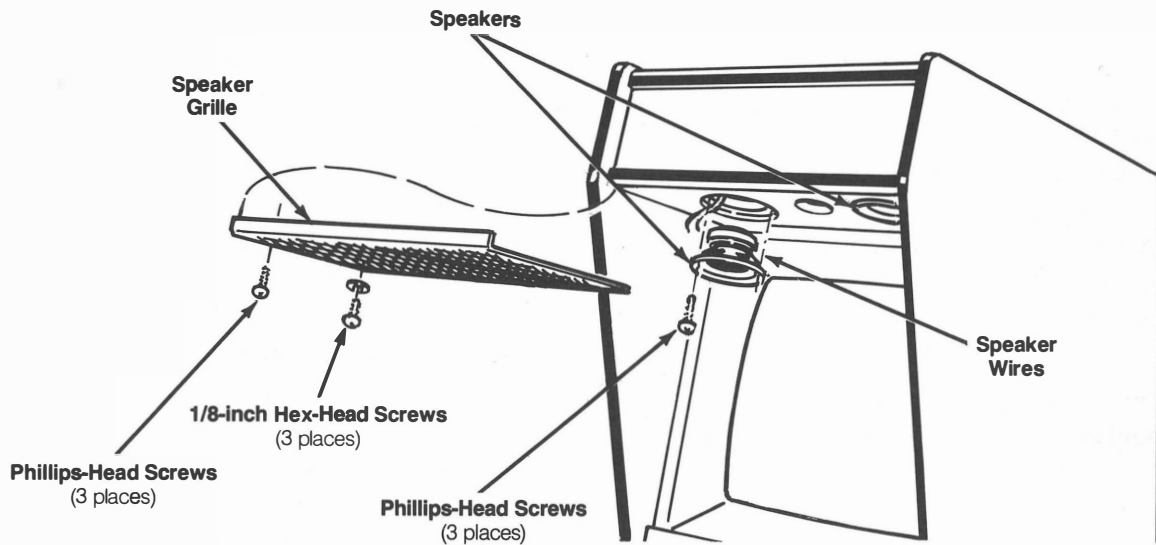

Figure 3-5 Speaker Removal

6. Repeat steps 1 through 5 to remove the remaining handlebar assembly.

7. Replace the handlebar assemblies in the reverse order of removal.

Removing the Handlebar Control

CAUTION

Do not attempt to disassemble the handlebar control while the control is mounted to the control panel. The control panel can be bent or damaged during disassembly. To avoid damaging the control panel, remove the handlebar control from the control panel before any corrective maintenance or repair is performed.

Perform the following procedure to remove/replace the handlebar control (see Figure 3-6).

1. Remove the control panel as described under *Preventive Maintenance*.
2. Use a 7/16-inch combination wrench to remove the four locknuts and washers that secure the handlebar control to the control panel.
4. Carefully remove the handlebar control from the control panel.
5. Replace the handlebar control in the reverse order of removal.

Disassembling the Accelerator Unit

Perform the following procedure to disassemble the accelerator unit (see Figure 3-8).

NOTE

It is not necessary to remove the accelerator unit from the steering unit to perform the following disassembly procedure. However, if you prefer, refer to steps 1 through 11 under *Disassembling the Steering Unit* for the procedure that describes how to separate the two units.

1. Use a Phillips screwdriver to remove the four screws that hold the U-shaped cover to the accelerator-unit frame.
2. Remove the right and left handlebar assemblies as previously described.
3. Gently pull the pushbutton leaf switch wires from the hollow accelerator-unit axle.
4. Cut the wire tie that holds the wire harness to the accelerator frame.
5. Use a 5/16-inch wrench to remove the anchor nut and anchor pin from the accelerator-unit axle.

6. Use a pair of pliers to release the straight end of the single-hook torsion spring from the accelerator-unit frame.
7. Use a 7/64-inch hex driver to remove the cap screw that holds the large spur gear onto the accelerator-unit axle.
8. Slide the accelerator-unit axle from the accelerator-unit frame. Be careful not to drop the large spur gear and the housing with the torsion springs attached.
9. Use a 7/64-inch hex driver to loosen the cap screw that holds the small spur gear to the vertical potentiometer shaft.
10. Remove the small spur gear from the potentiometer shaft.
11. Use a 1/2-inch combination wrench to remove the nut and washer that hold the potentiometer to the mounting bracket.

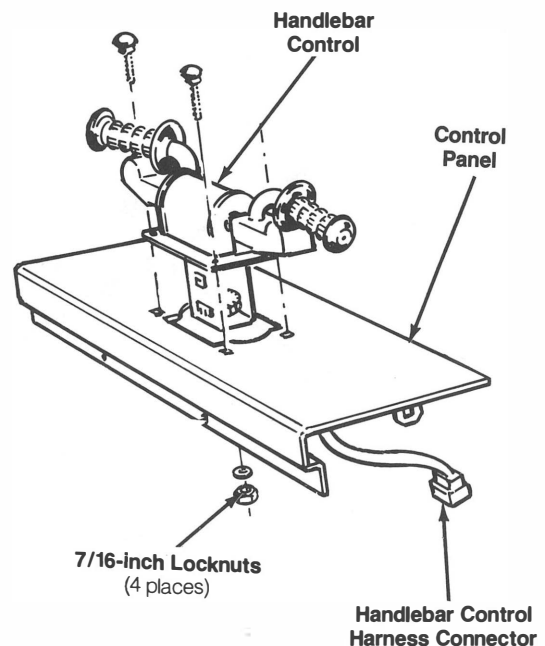

Figure 3-6 Handlebar Control Removal

12. Slide the potentiometer from the bracket. Be careful not to lose the small spur gear, nut, and washer.
13. Reassemble the accelerator unit as described in the following procedure.

Reassembling the Accelerator Unit

Perform the following procedure to reassemble the accelerator unit (see Figures 3-7 and 3-8).

1. If applicable, assemble the housing with the torsion springs and modification bearings installed as shown in Figure 3-7.
2. Apply a heavy film of Nyogel 779 lubricant (Atari part no. 178027-001) to the torsion springs and to the surface of the housing under the torsion springs.
3. Apply a light film of machine oil (Atari part no. 107013-001) to the inside surfaces and outer flanges of the bearings in each end of the housing and to the two bearings in the accelerator frame.

NOTE

The remainder of the accelerator-unit reassembly procedure starts with the accelerator unit positioned so that the square hole in the front of the frame is located near the left-hand side (opposite from that shown in Figure 3-8).

4. Place the housing (assembled as shown in Figure 3-7) inside the accelerator-unit frame with the pin positioned through the square hole in the front of the frame. Place the left-hand end of the housing against the bearing on the left-hand side of the frame as shown in Figure 3-8.
5. Locate the groove cut around the accelerator-unit axle near one end. Slide *that* end of the axle through the left-hand bearing in the accelerator-unit frame and through the housing. Do not insert the axle past the end of the housing.
6. Place the large (60-tooth) spur gear inside the accelerator-unit frame and against the end of the housing with the spur-gear collar facing the bearing on the right-

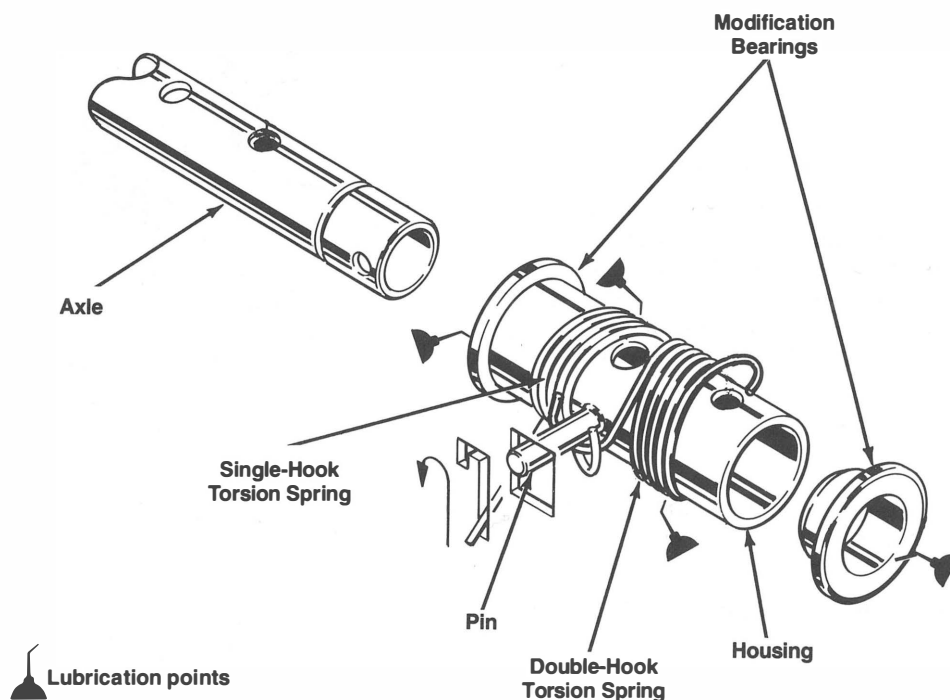

Figure 3-7 Torsion Spring and Modification Bearing Installation

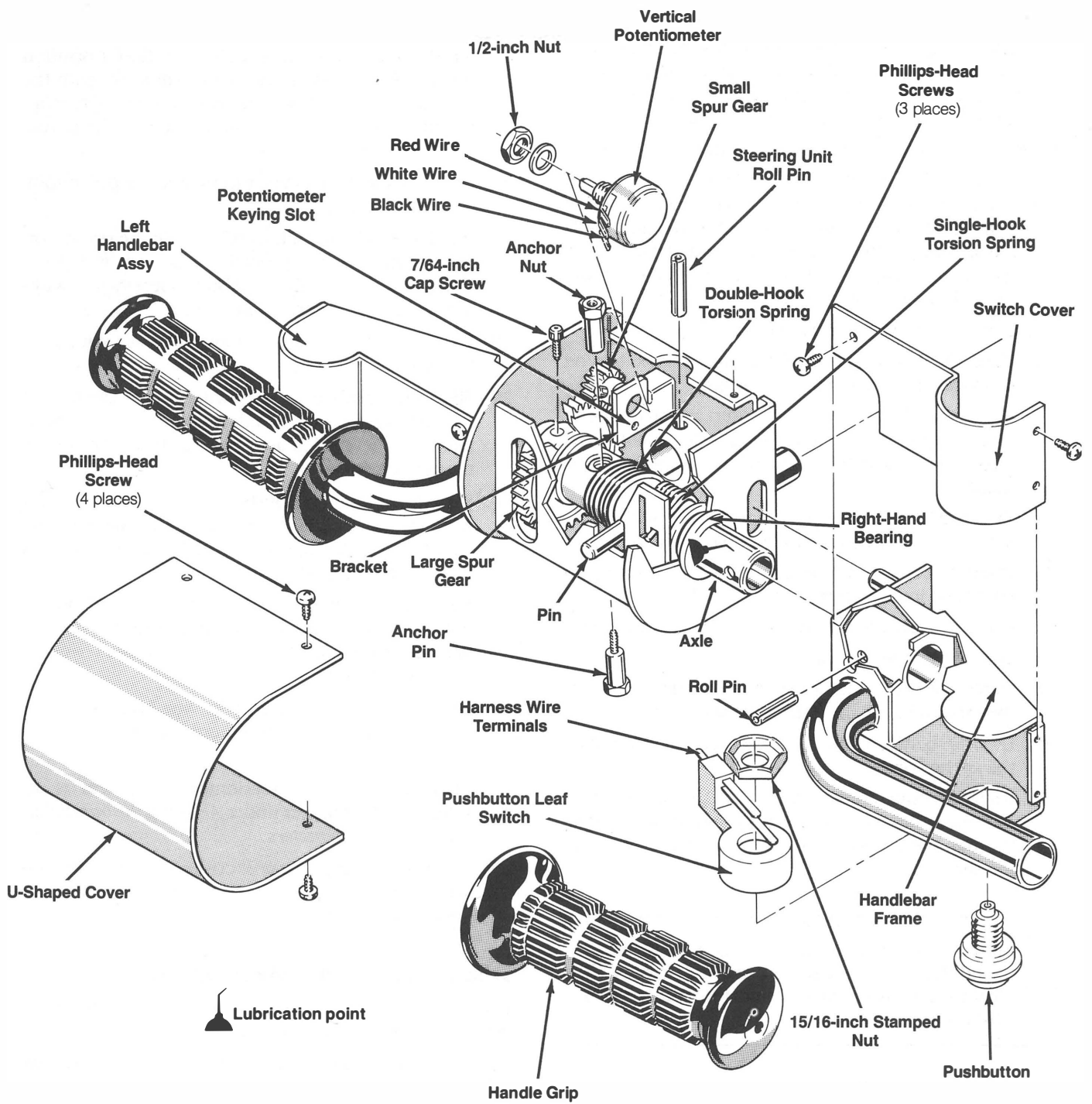

Figure 3-8 Accelerator Unit Disassembly/Reassembly

hand side of the frame. Hold the spur gear in line with the housing and the axle.

7. Slide the axle through the spur gear and through the bearing in the right-hand side of the frame.
8. Position the axle so that the small hole through the axle is aligned with the hole nearest the right-hand end of the housing. Make sure that the large hole in the axle is *not* aligned with the hole in the left-hand side of the housing. If it is, turn the axle 180°.
9. Place the hooked end of the double-hook torsion spring around the pin in the housing.
10. Catch the hook in the double-hook torsion spring with the threaded end of the anchor pin and guide the anchor pin (with the hooked end of the torsion spring around it) through the hole in the housing and through the hole in the axle.
11. Turn the handlebar control over.
12. Place the hooked end of the single-hook torsion spring around the pin in the housing.
13. Use a pair of pair of pliers to insert the straight end of the single-hook torsion spring into the slot in the top of the frame (near the right-hand side of the frame).
14. Turn the large spur gear to align the cap screw hole in the collar with the threaded hole in the axle.
15. Insert the cap screw through the hole in the spur-gear collar and into the threaded hole in the axle.
16. Use a 7/64-inch hex driver to tighten the cap screw.
17. Turn the handlebar control over.
18. Apply one drop of adhesive (part no. 106007-001) to the threads inside the end of the anchor nut.
19. Use a 5/16-inch wrench to tighten the anchor nut on the anchor pin.
20. Insert the potentiometer shaft through the hole in the mounting bracket. Before fully inserting the shaft through the bracket, place the washer and nut onto the shaft.
25. Position the small spur gear so that the cap screw is in line with the flat side of the potentiometer shaft and gently slide the small spur gear, with the collar facing the potentiometer, onto the potentiometer shaft. Make sure the small spur gear collar is pushed tight against the threaded barrel of the potentiometer. (It may take some searching to find a position where the small spur-gear teeth will mesh with the large spur gear and will still keep the cap screw approximately aligned with the flat side of the potentiometer shaft.)
26. Use a 7/64-inch hex driver to tighten the potentiometer cap screw.
27. Install the right and left handlebars in the reverse order of the removal procedure. Do not install the switch covers until the pushbutton leaf switch wires are installed as described in step 28.
28. Locate the pushbutton leaf switch wires with a tag labeled *RT*.
29. Slide the pushbutton leaf switch wires labeled *RT* through the hole in the axle and into the right-hand handlebar (to the left as viewed from the bottom of the accelerator unit).
30. Slide the remaining pushbutton leaf switch wires through the hole in the axle and into the left-hand handlebar (to the right as viewed from the bottom of the accelerator unit).
31. Solder the two wires (labeled *RT*) to the pushbutton leaf switch terminals. If applicable, solder the potentiometer leads to the proper potentiometer terminals as shown in Figure 3-8.
32. Replace the wire tie around the wire harness and fasten the harness to the tie mount on the accelerator-unit frame.
33. Check the vertical potentiometer alignment as described in this chapter under *Aligning the handlebar Control Potentiometers*.
34. Install the accelerator-unit cover and use a Phillips screwdriver to tighten the four screws that hold the cover onto the frame.

NOTE

If you are installing a new potentiometer, bend the potentiometer terminals back away from the shaft so they do not touch the anchor nut.

21. Align the potentiometer so that the tab key is inserted into the keying slot in the mounting bracket.
22. Use a ½-inch wrench to tighten the nut on the potentiometer shaft.
23. Turn the potentiometer shaft so that the flat side faces the center (white) wire terminal on the potentiometer.

Disassembling the Steering Unit

Perform the following procedure to disassemble the steering unit (see Figures 3-8 and 3-9).

1. Use a Phillips screwdriver to remove the four screws that hold the U-shaped cover to the accelerator-unit frame.
2. Use a Phillips screwdriver to remove the three screws that hold the handlebar covers onto the right and left handlebar assemblies.
3. Remove the pushbutton leaf switches as described previously.

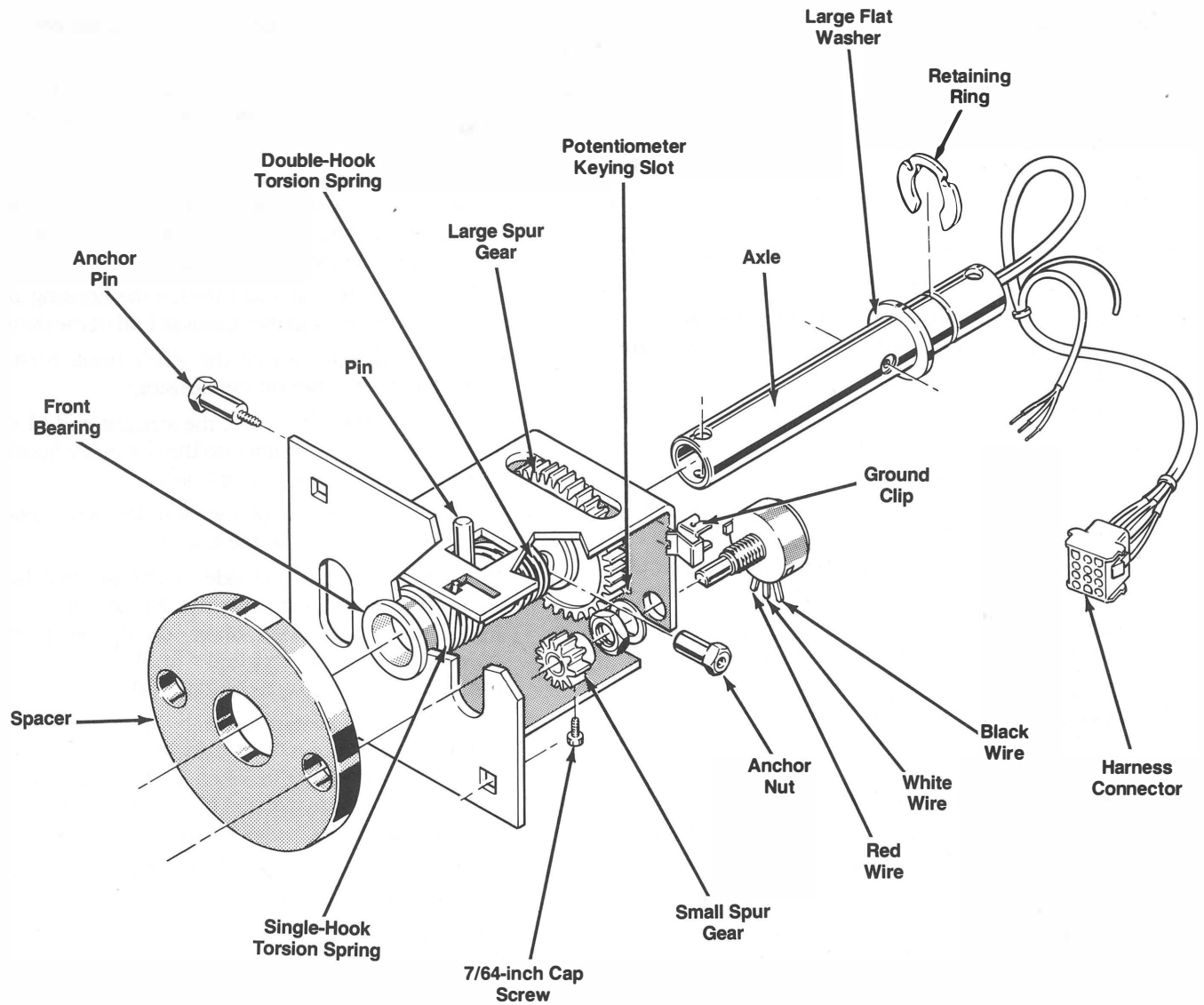

Figure 3-9 Steering Unit Disassembly/Reassembly

4. Unsolder the three harness wires from the vertical potentiometer.
5. Cut the wire tie that holds the wire harness to the steering-unit frame.
6. Gently pull the harness from the hollow steering-unit axle.
7. Use a 7/64-inch hex driver to loosen the cap screw that holds the small spur gear to the vertical potentiometer shaft.
8. Use a 1/2-inch wrench to remove the nut and washer that holds the vertical potentiometer to the mounting bracket.
9. Remove the vertical potentiometer.
10. Use a 3/16-inch punch to knock out the roll pin that holds the steering unit axle to the accelerator unit.
11. Separate the steering unit from the accelerator unit.
12. Use a 5/16-inch wrench to remove the anchor nut and anchor pin from the steering-unit axle.
13. Use a pair of pliers to release the straight end of the single-hook torsion spring from the steering-unit frame.
14. Use a 7/64-inch hex driver to remove the cap screw that holds the large spur gear onto the steering-unit axle.
15. Slide the steering-unit axle from the steering-unit frame. Be careful not to drop the large spur gear and the housing with the torsion springs attached.

⚠ WARNING ⚠

Shield your face and eyes when prying the retaining ring from the steering axle because the retaining ring can fly loose at a high velocity. Cover the retaining ring with a piece of cloth that will trap the ring.

16. If desired, use a slotted screwdriver to remove the retaining ring from the steering axle.
17. Use a 7/64-inch hex driver to loosen the cap screw that holds the small spur gear to the potentiometer shaft.
18. Remove the small spur gear from the potentiometer shaft.
19. Use a ½-inch combination wrench to remove the nut and washer that hold the horizontal potentiometer to the steering-unit frame.
20. If desired, unsolder the three wires from the potentiometer terminals.
21. Slide the potentiometer from the frame. Be careful not to lose the small spur gear, nut, and washer.
22. Reassemble the steering unit as described in the following procedure.

Reassembling the Steering Unit

Perform the following procedure to reassemble the steering unit (see Figures 3-7 and 3-9).

1. Use a pair of pliers to snap the retaining ring into the steering-unit axle groove which is nearest the threaded hole used to hold the large (60-tooth) spur gear to the axle.
2. Slide the large flat washer down the long end of the shaft and against the retaining ring.
3. If applicable, assemble the housing with the torsion springs and modification bearings installed, as shown in Figure 3-9.
4. Apply a light film of machine oil (Atari part no. 107013-001) to the inside surfaces and outer flanges of the bearings in each end of the housing and to the two bearings in the steering-unit frame.
5. Apply a heavy film of Nyogel 779 lubricant (Atari part no. 178027-001) to the torsion springs and to the surface of the housing under the torsion springs.
6. Slide the end of the steering-unit axle opposite the retaining ring just to the inside edge of the bearing at the back of the steering-unit frame.
7. Place the large (60-tooth) spur gear inside the steering-unit frame with the spur-gear collar facing the bearing on the back of the frame. Hold the spur gear in line with the bearing and the axle.
8. Slide the steering-unit axle just to the inside edge of the spur gear.
9. If applicable, assemble the housing with the torsion springs and modification bearings installed, as shown in Figure 3-7.
10. Place the housing (assembled as shown in Figure 3-7) inside the steering-unit frame with the pin positioned through the square hole in the side of the frame and align the housing with the spur gear.
11. Slide the steering-unit axle through the housing and through the bearing in the opposite end of the frame.
12. Place the hooked end of the single-hook torsion spring around the pin on the housing.
13. Use a pair of pliers to insert the straight end of the single-hook torsion spring into the slot in the bottom of the frame (near the square hole).
14. Place the hooked end of the double-hook torsion spring around the pin in the housing.
15. Position the steering-unit axle so that the small hole through the axle is aligned with the hole in the housing nearest the spur gear. Make sure the other large hole in the housing is aligned with the large hole in the axle. If it is not, turn the axle 180°.
16. Catch the hook in the double-hook torsion spring with the threaded end of the anchor pin. Guide the anchor pin (with the hooked end of the torsion spring around it) through the hole in the housing and then through the hole in the axle.
17. Apply one drop of adhesive (Atari part no. 106007-001) to the threads inside the anchor nut.
18. Use a 5/16-inch wrench to tighten the anchor nut on the anchor pin.
19. Turn the large spur gear to align the cap screw hole in the collar with the threaded hole in the axle.
20. Insert the cap screw through the hole in the spur-gear collar and into the threaded hole in the axle.
21. Use a 7/64-inch hex driver to tighten the cap screw.
22. Insert the potentiometer shaft through the hole in the back of the frame. Before fully inserting the shaft through the frame, place the washer and nut onto the shaft.
23. Align the potentiometer so that the tab key is inserted into the keying slot in the frame.
24. Use a ½-inch wrench to tighten the nut on the potentiometer shaft.
25. Turn the potentiometer shaft so that the flat side faces the center (white) wire terminal on the potentiometer.
26. Position the small spur gear so that the cap screw is in line with the flat side of the potentiometer shaft. Gently slide the small spur gear, with the collar facing

the potentiometer, onto the potentiometer shaft. Make sure the small spur gear collar is pushed tight against the threaded barrel on the potentiometer. (It may take some searching to find a position where the small spur gear teeth will mesh with the large spur gear and will still keep the cap screw approximately aligned with the flat side of the potentiometer shaft.)

27. Use a 7/64-inch hex driver to tighten the potentiometer cap screw.
28. Place the spacer against the back of the accelerator-unit frame with the two large pins inserted through the corresponding holes in the spacer.
29. Guide the axle on the front of the steering unit into the hole and collar in the accelerator-unit frame.
30. Align the hole in the end of the steering-unit axle with the hole in the accelerator-unit collar.
31. Use a 3/16-inch punch to drive the roll pin through the collar in the accelerator unit and through the steering-unit axle.
32. From the back of the steering unit, slide the harness wires through the hollow steering-unit axle. The wires for the horizontal potentiometer and the green ground wire should remain outside the axle.

NOTE

Do not install the switch covers until the vertical potentiometer and pushbutton leaf switch wires are installed as described in the following steps.

33. Locate the pushbutton leaf switch wires with a tag labeled *RT*.
34. Slide the pushbutton leaf switch wires labeled *RT* through the hole in the accelerator-unit axle and into the right-hand handlebar (to the left as viewed from the bottom of the accelerator unit).
35. Slide the remaining pushbutton leaf switch wires through the hole in the accelerator-unit axle and into the left-hand handlebar (to the right as viewed from the bottom of the accelerator unit).
36. Solder the vertical and horizontal potentiometer wires to the proper potentiometer terminals as shown in Figures 3-8 and 3-9.
37. Solder the two wires to the pushbutton leaf switch terminals and install the pushbutton leaf switches to the handlebar frame.
38. Check the horizontal potentiometer alignment as described in this chapter under *Aligning the handlebar Control Potentiometers*.
39. Replace the wire ties around the wire harnesses and attach the wire harness to the tie mounts on the accelerator- and steering-unit frames.

40. Install the ground clip, with the green wire attached, to the back of the steering-unit frame as shown in Figure 3-9.
41. Install the switch covers on the right and left handlebar assemblies and use a Phillips screwdriver to tighten the three screws that hold the covers onto the handlebar assemblies.
42. Install the U-shaped cover on the accelerator-unit frame and use a Phillips screwdriver to tighten the four screws that hold the cover onto the frame.

Aligning the Handlebar Control Potentiometers

The following procedures describe the method for checking and mechanically aligning the vertical and horizontal handlebar control potentiometers. The potentiometers must be properly aligned to ensure that the player-controlled paperboy on the display is centered when the handlebar control is released.

Preliminary Procedure

Perform the following procedure to determine if the handlebar control vertical or horizontal potentiometers are misaligned.

1. Turn off the game power.
2. Set the self-test switch to the on position.
3. Turn on the game power.
4. Perform the Control Test procedure for checking the handlebar control range as described in Chapter 2. If the self-test display indicates that the handlebar control vertical or horizontal range is out of tolerance, perform the appropriate procedure.

Vertical Potentiometer

Perform the following procedure to align the handlebar control vertical potentiometer (see Figure 3-8).

1. Turn off the game power.
2. If necessary, use a Phillips screwdriver to remove the four screws that hold the U-shaped cover to the accelerator unit to gain access to the vertical potentiometer.
3. With the handlebar control centered (no tension on the return springs), check that the cap screw on the small (14-tooth) spur gear is facing the center (white) wire terminal on the vertical potentiometer. If it is not, use a 7/64-inch hex driver and loosen the cap screw that holds the small spur gear to the potentiometer shaft and remove the small spur gear.
4. Turn on the game power.
5. Turn the potentiometer shaft until the Control Test display (obtained in the Preliminary Procedure) indi-

cates that the vertical potentiometer is within the allowable limits.

6. Position the small spur gear so that the cap screw is in line with the flat side of the potentiometer shaft and gently slide the small spur gear onto the potentiometer shaft. (If necessary, slightly move the large gear to align the spur gear teeth—do not turn the potentiometer shaft.) Recheck the Control Test display limits.
7. Use a 7/64-inch hex driver to tighten the spur-gear cap screw. Recheck the Control Test display to make certain the horizontal range is still within the allowable limits.
8. Install the U-shaped cover on the accelerator unit and use a Phillips screwdriver to tighten the four screws that hold the cover to the frame.

Horizontal Potentiometer

Perform the following procedure to align the handlebar control horizontal potentiometer (see Figure 3-9).

1. Turn off the game power.
2. Remove the control panel as described under *Preventive Maintenance*.
3. With the handlebar control centered (no tension on the return springs), check that the cap screw on the small (14-tooth) spur gear is facing the center (white) wire terminal on the horizontal potentiometer. If it is not, use a 7/64-inch hex driver and loosen the cap

screw that holds the small spur gear to the potentiometer shaft and remove the small spur gear.

4. Turn on the game power.
5. Turn the potentiometer shaft until the Control Test display (obtained in the Preliminary Procedure) indicates that the horizontal potentiometer is within the allowable limits.
6. Position the small spur gear so that the cap screw is in line with the flat side of the potentiometer shaft and gently slide the small spur gear onto the potentiometer shaft. (If necessary, slightly move the large gear to align the spur gear teeth—do not turn the potentiometer shaft.) Recheck the Control Test display limits.
7. Use a 7/64-inch hex driver to tighten the spur-gear set screw. Recheck the Control Test display to make certain the horizontal range is still within the allowable limits.

Calibrating the Handlebar Control

The handlebar control normally calibrates itself during normal game play, but may take several seconds of game play to be optimized. The game circuitry monitors the control and calibrates the vertical and horizontal potentiometers. Calibrate the handlebar control after any corrective maintenance is performed by following the procedure described under *Control Test* in Chapter 2.

Troubleshooting

The information in this chapter discusses troubleshooting aids and techniques to assist the service technician when a trouble is suspected in this game. Most troubles can be located quickly by following the information in this section. However, if problems persist, contact your nearest Atari Games Corporation Customer Service Office, listed on the inside front cover of this manual, for assistance.

A thorough knowledge of game operation is desirable for effective troubleshooting. In addition to the operation and service information in the Schematic Package Supplement included with this manual, refer to *The Book, A Guide To Electronic Game Operation and Servicing*. This publication is available from Atari Games Corporation and has more information on coin-operated electronic games.

NOTE

We recommend that troubleshooting and repair procedures be performed by a qualified service technician.



Chapter 4

Troubleshooting Aids

Troubleshooting aids are provided throughout this manual and the Schematic Package Supplement. The following information is intended to acquaint the service technician with the portions of these documents that contain useful troubleshooting and repair information.

Assembly and Component Locations

The parts lists in Chapters 5 illustrate the locations of assemblies and components. Printed-circuit board (PCB) illustrations aid in rapidly locating components shown on the corresponding schematic diagram(s).

Diagrams

The Schematic Package Supplement included with this game contains schematic diagrams with component locations, active component type numbers, and electrical values.

Troubleshooting Procedures

Refer to the following section, *Troubleshooting Techniques*, for a suggested troubleshooting sequence to aid in locating defective components.

Troubleshooting Techniques

⚠ WARNING ⚠

To avoid electrical shock, turn off the game power before attempting to troubleshoot this game.

The following troubleshooting steps are arranged in a sequence recommended for locating a defective component. The procedure begins with a check of the simple trouble possibilities and progresses to more extensive procedures for localizing the problem to an assembly or major circuit, and then to a defective component.

Check Switch Settings

Incorrect switch settings can sometimes indicate a problem that does not exist. Refer to Chapter 1 to verify that the game has been installed properly and the option settings are correct. Refer to Chapter 2 for instructions on how to set the options. Check for proper operation in all game play modes.

Check Fuses

Check for open fuses. Refer to the power supply parts list in Chapter 5 and to the Display Manual for the location

and rating of each fuse used in this game. Make sure that replacement fuses are the proper type and rating.

Check Power-Supply Voltages

Improper operation of all circuits usually indicates a power supply problem. Be sure that the proper line voltage is available to the power supply. Check for correct voltages.

Localize Trouble

Determine the trouble symptom. Use the wiring diagrams in the Schematic Package Supplement to determine which assemblies or major circuits could cause the trouble. Perform the self-test procedure provided in Chapter 2.

Visual Check

Visually check for obvious problems in the portion of the game where the trouble is suspected. For example, check for loose or defective solder connections, integrated circuits loose in their sockets, loose cable connections, broken wires, and damaged PCBs or components.

Check Individual Components

Check soldered-in passive components (e.g., resistors, capacitors, diodes) by disconnecting one end to isolate the measurement from the effects of the surrounding circuitry. Often, direct substitution is the most practical way to determine if a component is faulty. However, eliminate the possibility of some other circuit problem that could damage the substitute component.

Repair the Assembly

CAUTION

Soldered-in transistors and integrated circuits are difficult to remove without damaging the printed-circuit board or component. Refer to the information in this chapter pertaining to soldering and replacing integrated circuits and transistors.

Repair or replace the defective part. Refer to Chapter 3 and information in this chapter for special removal and replacement procedures. Check for proper operation of the repaired circuit.

Soldering Techniques

Observe the following recommendations when removing or replacing components soldered to a PCB. Poor soldering practices can damage a PCB or heat-sensitive electrical components.

Choosing the proper soldering iron is essential before attempting to remove or replace soldered-in components. Excessive heat is a common cause of damage to a component or PCB. However, transient voltages from solder guns or improperly grounded soldering irons can also damage certain voltage-sensitive semiconductor devices. Refer to *Troubleshooting Static-Sensitive Devices* for more specific information.

A 15- to 27-watt pencil-tip soldering iron is recommended to avoid separating the etched circuit wiring from the board material and to avoid damaging active components. A temperature-controlled soldering station rated at 700°F with a fine cone or a very fine chisel tip can also be used.

CAUTION

Solder guns are not recommended for removing or replacing soldered-in components on a printed-circuit board. The added possibility for overheating and the large transient voltage induced by the solder gun could cause damage to heat- or voltage-sensitive devices.

The following additional equipment is recommended for removing and replacing soldered-in components:

- Solder Sucker—Hand-operated vacuum tool used to remove liquified solder from the PCB. We recommend the top-of-the-line Soldapull® brand.
- Solder Wick—Resin-soaked copper braid used for removing excess solder from the lead connections on the PCB. See *Removing Integrated Circuits* for precautions relating to the use of a solder wick on a multi-layer PCB with plated-through holes.
- Flux Remover—Non-corrosive chemical used to clean foreign material from the PCB before soldering and to remove any flux residue where components have been replaced. Also used to clean any foreign material from the PCB during preventive maintenance. Isopropyl alcohol is recommended.
- Acid Brush—Small stiff-bristled paint or toothbrush used with flux remover to clean flux and other foreign material from the PCB.

Removing Integrated Circuits

The easiest and safest method for removing soldered-in integrated circuits (IC) from a PCB is to cut off each pin as close to the IC case as possible with a tip dyke (diagonal cutter) as shown in Figure 4-1.

Use the proper soldering iron as previously described under *Soldering Techniques*. Then, to avoid excessive heat buildup in one area of the PCB, apply heat directly to each pin in a random order. Remove the loosened pin with the

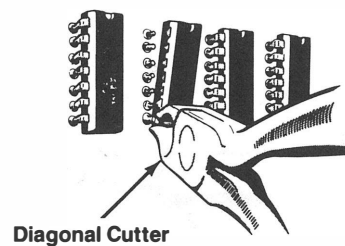

Figure 4-1 Removing IC (Cut-Pin Method)

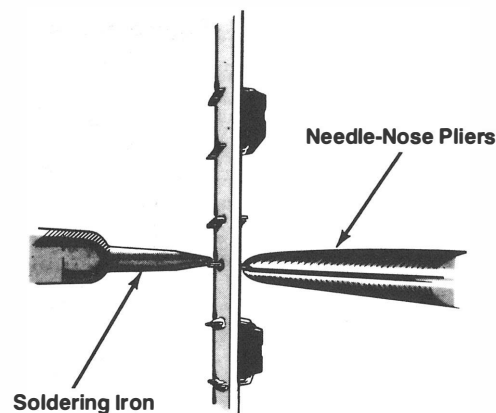

Figure 4-2 Removing IC Pins

tip of the soldering iron or a needle-nose pliers as shown in Figure 4-2. Allow a moment for the PCB to cool before proceeding to the next pin. Apply just enough heat to remove any stubborn pins.

For a multi-layer PCB with plated-through holes, use a solder sucker to remove the remaining solder from inside each hole as shown in Figure 4-3. If possible, suck the solder from the opposite side of the PCB from where the heat is applied.

Use a solder wick to remove excess solder from around the lead connection pads on the top and/or bottom surface of the PCB as shown in Figure 4-4.

CAUTION

Do not use a solder wick to remove solder from inside plated-through holes. The heat required for the solder wick to remove the solder from inside the hole could damage the PCB.

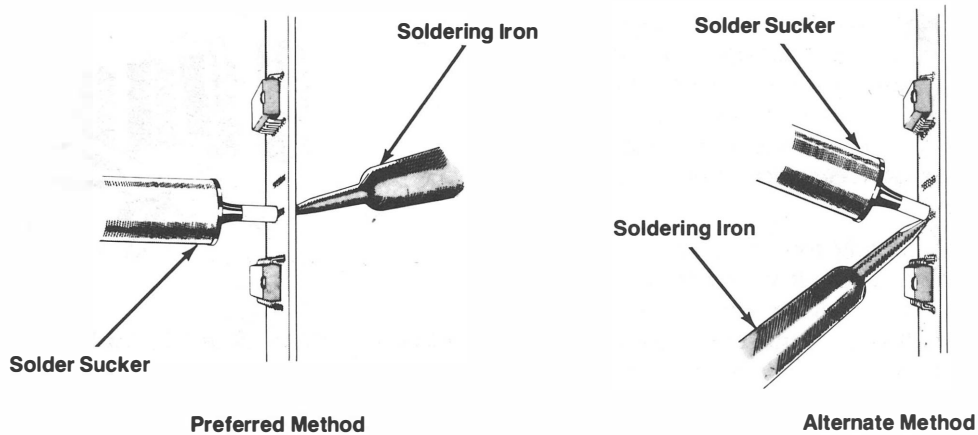

Figure 4-3 Removing Solder from Plated-Through Holes

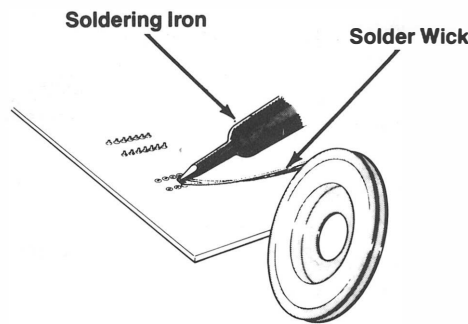

Figure 4-4 Removing Solder from Lead Connection Pads

Use an integrated-circuit (IC) pulling tool to remove socketed ICs. Do not pry up on one end of the ICs, because the pins could be bent or broken.

Troubleshooting Static-Sensitive Devices

Certain precautions must be taken when working with static-sensitive devices, e.g., microprocessors, field-effect transistors (FET), complementary metal-oxide semiconductors (CMOS), and other large-scale integration (LSI) devices that use metal-oxide semiconductor (MOS) technology. Static charge buildup in a person's body or leakage from an improperly grounded soldering iron can cause static-sensitive device failure.

Before handling a static-sensitive device or a PCB with such devices attached to it, ground any static voltage that may have accumulated in your body by touching an object that has been earth grounded. A bare wire wrapped around your wrist and attached to an earth ground is ef-

fective when working extensively with static-sensitive devices. When soldering on a static-sensitive device, use a soldering iron with a properly grounded three-wire cord. (Refer to *Soldering Techniques* for a discussion of recommended soldering irons and procedures.)

A static-sensitive device may appear defective due to leakage on a PCB. Observe the precautions for grounding static voltages described in the preceding paragraph and clean both sides of the PCB with flux remover or an eraser before replacing what may be a good static-sensitive device. For discrete FETs, clean thoroughly between the gate, drain, and source leads.

Static-sensitive devices may be packaged in conductive foam or have a protective shorting wire attached to the pins. Remove the conductive foam just prior to inserting the device into its socket or soldering it to a PCB. Remove the shorting wire only *after* the device is inserted into its socket or *after* all the leads are soldered in place.

Illustrated Parts Lists



This chapter provides information you need to order parts for your game. Common hardware (screws, nuts, washers, etc.) has been deleted from most of the parts lists. However, a parts list is included for the hardware to mount the printed-circuit boards (PCB) to the cabinet.

The PCB parts lists are arranged in alphabetical order by component. Each component subsection is arranged alphanumerically by reference designator.

Other parts lists are arranged alphanumerically by Atari part number. In these parts lists, all A-prefix numbers come first. Following these are numbers in sequence evaluated up to the hyphen, namely 00- through 99-, then 000598- through approximately 201000-.

When ordering parts, please give the part number, part name, number of this manual, and serial number of your game. This will aid in filling your order rapidly and correctly. We hope the results will be less downtime and more profit from your game.

Atari Customer Service numbers are listed on the inside front cover of this manual.

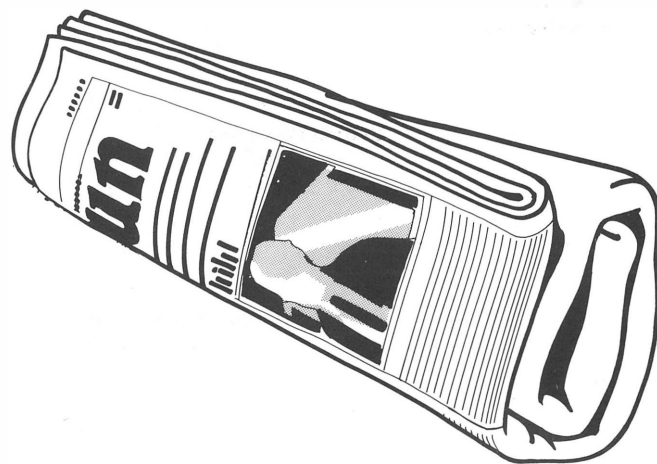

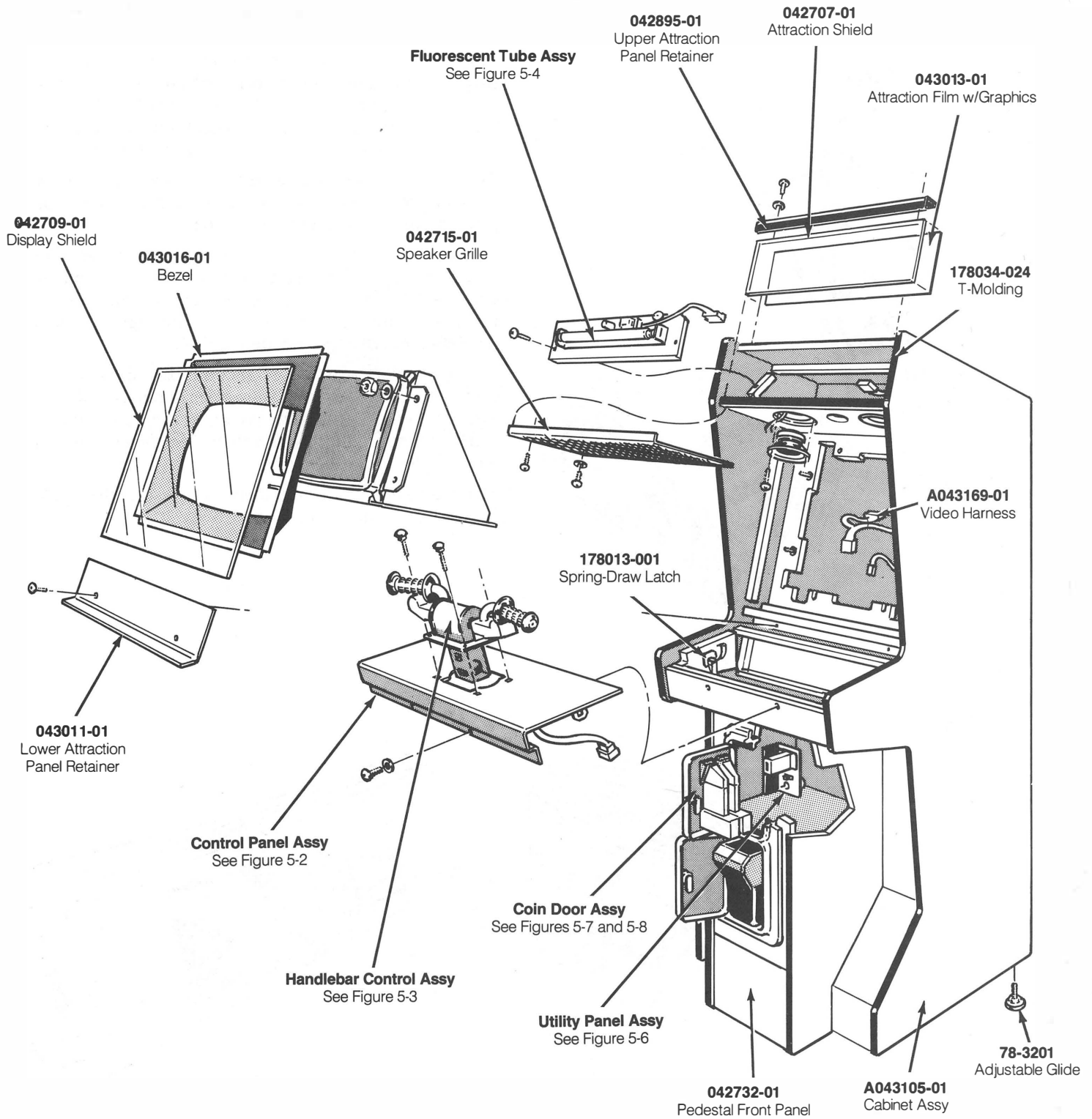

**Figure 5-1 Cabinet-Mounted Assemblies
A043000-01 E**

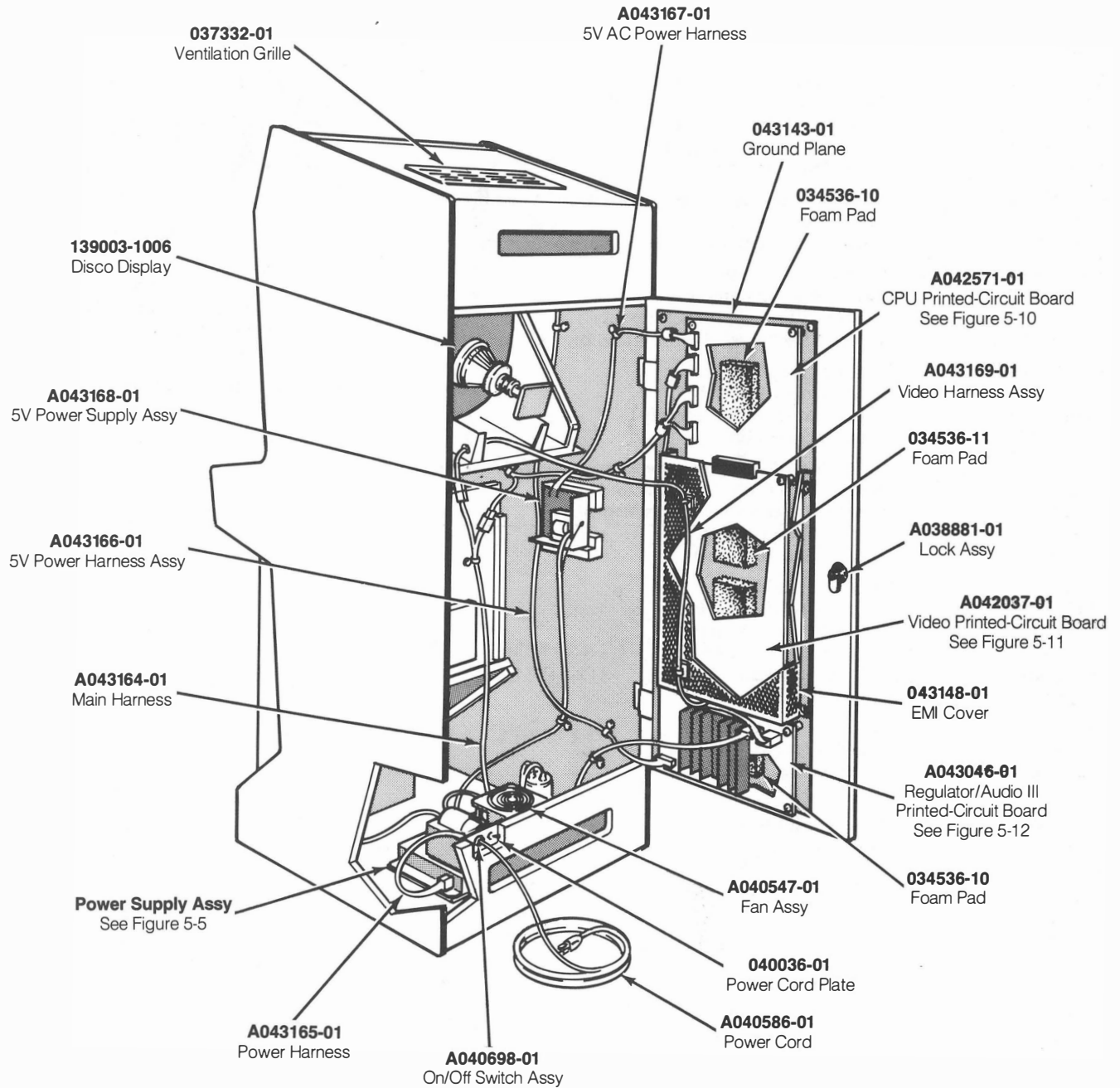
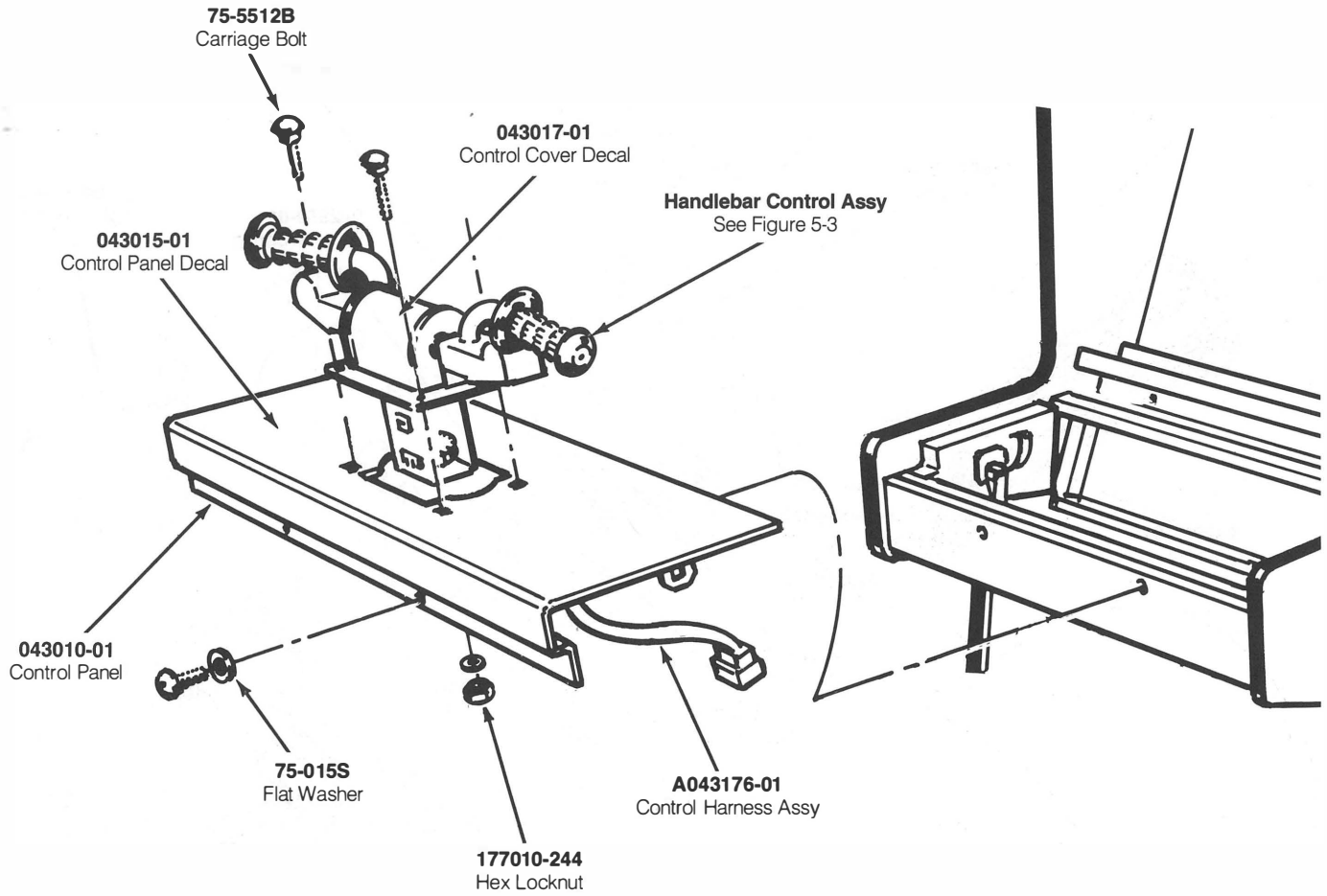

Figure 5-1 Cabinet-Mounted Assemblies, continued
A043000-01 E

Cabinet-Mounted Assemblies Parts List

Part No.	Description
A038881-01	Lock Assembly for Rear Panel
A040547-01	Fan and Bracket Assembly
A040586-01	Power Cord Assembly
A040698-01	On/Off Switch Assembly with Harness
A042037-01	Video Printed-Circuit Board Assembly
A042571-01	CPU Printed-Circuit Board Assembly
A042701-01	Fluorescent Tube Assembly
A042935-01	Handlebar Control Assembly
A043002-01	Control Panel Assembly
A043046-01	Regulator/Audio III Printed-Circuit Board Assembly
A043105-01	Cabinet Assembly
A043146-01	Utility Panel Assembly
A043164-01	Main Harness Assembly
A043165-01	Power Harness Assembly
A043166-01	5V Power Supply Harness Assembly
A043167-01	5V Power Supply AC Harness Assembly
A043168-01	5V Power Supply Assembly
A043169-01	Video Harness Assembly
A043171-01	12-Inch Fan Harness Assembly
A043172-01	Y-Adapter Assembly
<i>The following four items are technical information supplements:</i>	
TM-210	Disco 19-Inch Color Display Manual
TM-275	System II/Paperboy Operators Manual
SP-275	Paperboy Schematic Package
ST-275	Paperboy Self-Test Label
78-3201	Adjustable Glide
034536-10	0.62-Inch Thick Foam Pad
034536-11	0.81-Inch Thick Foam Pad
037243-01	Power Supply Plate
037332-01	Ventilation Grille
040036-01	Power Cord Plate
042707-01	Attraction Shield
042709-01	Display Shield
042715-01	Speaker Grille
042732-01	Pedestal Front Panel
042895-01	Upper Attraction Panel Retainer
043011-01	Lower Attraction Panel Retainer
043013-01	Attraction Film with Graphics
043016-01	Display Bezel
043017-01	Handlebar Decal (not shown)
043123-01	Rear Door Panel
043143-01	Ground Plane
043148-01	EMI Cover
139003-1006	Disco Display Assembly
178013-001	Spring-Draw Latch
178034-024	3/4-Inch Black T-Molding



**Figure 5-2 Control Panel Assembly
A043002-01 B**

Parts List

Part No.	Description
A042935-01	Handlebar Control Assembly
A043176-01	Control Harness Assembly
75-015S	3/4-Inch Flat Washer
75-5512B	3/4-20 x 3/4-Inch Carriage Bolt
043010-01	Control Panel
043015-01	Control Panel Decal
043017-01	Control Cover Decal
177010-244	3/4-24 Hex Locknut

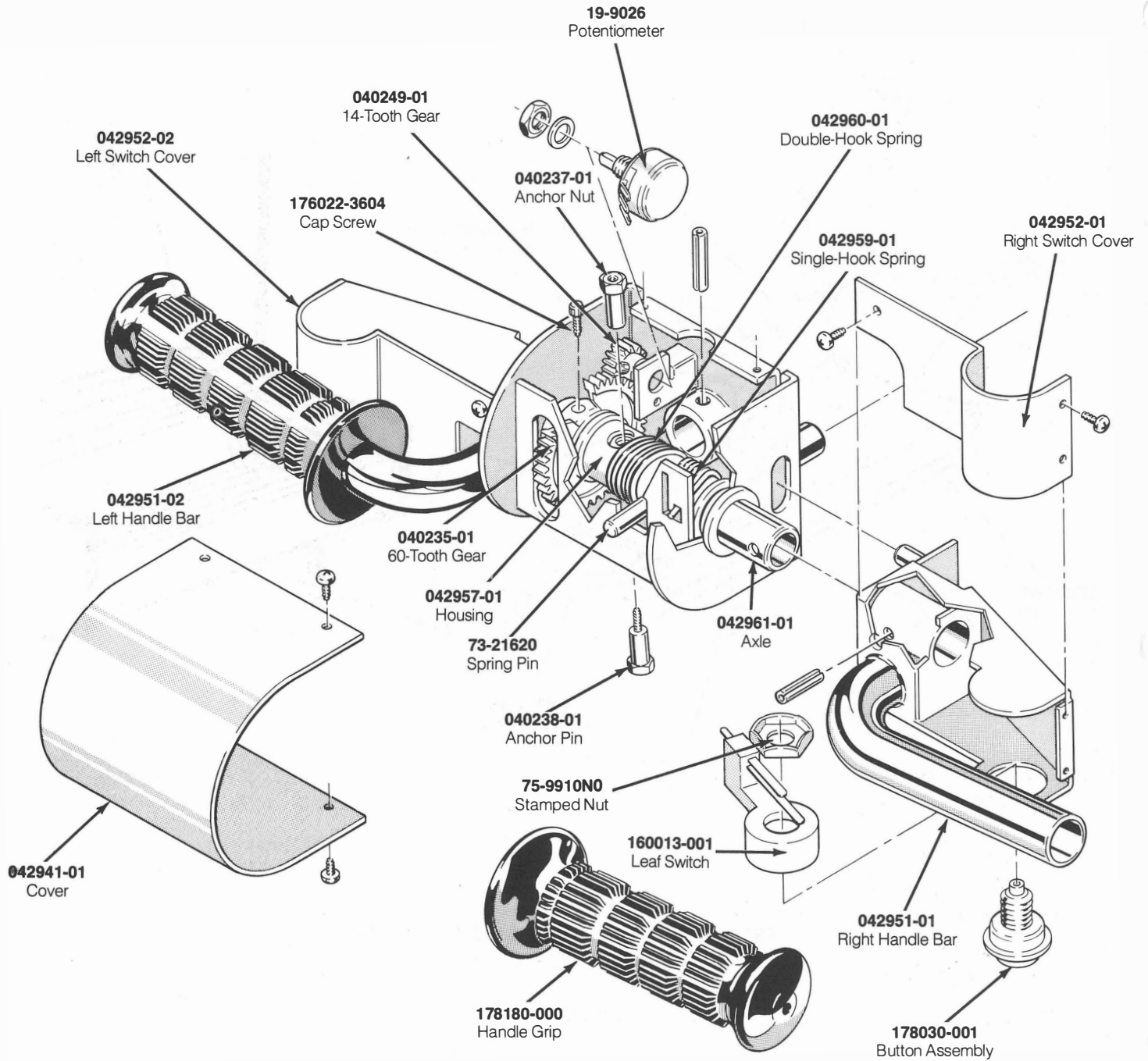

Figure 5-3 Handlebar Control Assembly
A042935-01 A

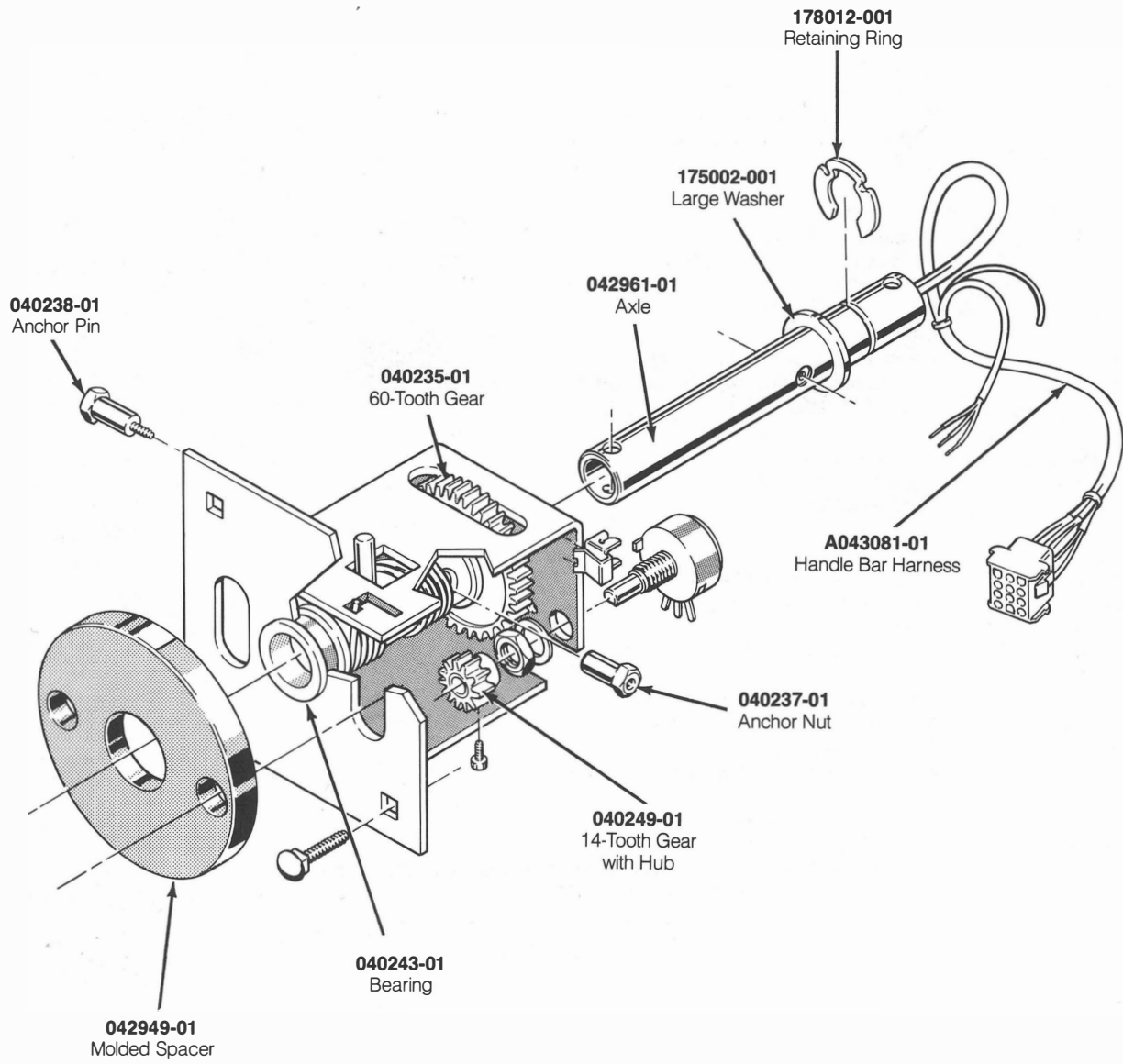
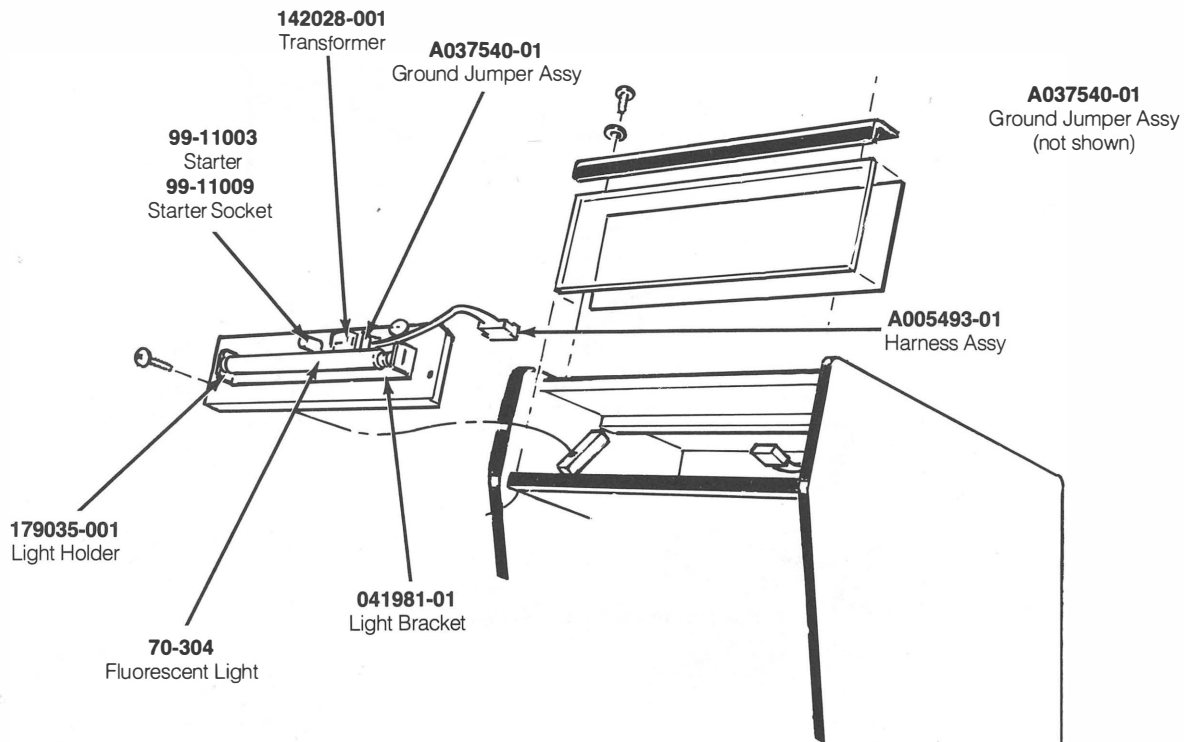

Figure 5-3 Handlebar Control Assembly, continued
A042935-01 A

Handlebar Control Assembly Parts List

Part No.	Description
A043081-01	Handlebar Harness Assembly
19-9026	5K Potentiometer
72-HA4806B	#8-32 × 3/8-Inch Cross-Recessed Round Head Screw
73-21620	3/4 × 1 3/4-Inch Spring Pin
75-9910N0	5/8-11 Stamped Nut
78-1701R	Penetrating Lubricant (not shown)
040235-01	60-Tooth Spur Gear with Hub
040237-01	Anchor Nut
040238-01	Anchor Pin
040243-01	Modification Bearing
040249-01	14-Tooth Spur Gear with Hub
042936-01	U-Frame
042941-01	Cover
042946-01	Frame Base
042949-01	Molded Spacer (Acceptable substitute is part no. 042950-01)
042951-01	Right Handlebar
042951-02	Left Handlebar
042952-01	Right Switch Cover
042952-02	Left Switch Cover
042957-01	Housing
042959-01	Single-Hook Torsion Spring
042960-01	Double-Hook Torsion Spring
042961-01	Axle
106007-001	Penetrating Adhesive (not shown)
107013-001	Lubricant (Machine Oil) (not shown)
160013-001	Leaf Switch with Button Holder
175002-001	3/4-Inch Large Washer
176022-3604	#6-32 × 3/4-Inch Self-Locking Cap Screw
178012-001	3/4-Inch Retaining Ring
178030-001	White Button Assembly
178180-000	Black Waffle Handle Grip (Acceptable substitutes are part numbers 178180-002—Red and 178180-006—Blue)



**Figure 5-4 Fluorescent Tube Assembly
A042701-01 A**

Parts List

Part No.	Description
A005493-01	Fluorescent Light Harness Assembly
A037540-01	Ground Jumper Assembly
70-304	18-Inch, 15 W Fluorescent Light
72-6408S	#4 x 1/2 -Inch Pan-Head Self-Tapping Screw (not shown)
79-561816P	Wire Nut
99-11003	Starter
99-11006	Retaining Clip (consists of two pieces)
99-11009	Starter Socket
041981-01	Light Bracket
042740-01	Light Panel
142028-001	60Hz Ballast Transformer
176015-110	#10 x 5/8-Inch Cross-Recessed Pan-Head Screw (not shown)
179035-001	Light Holder

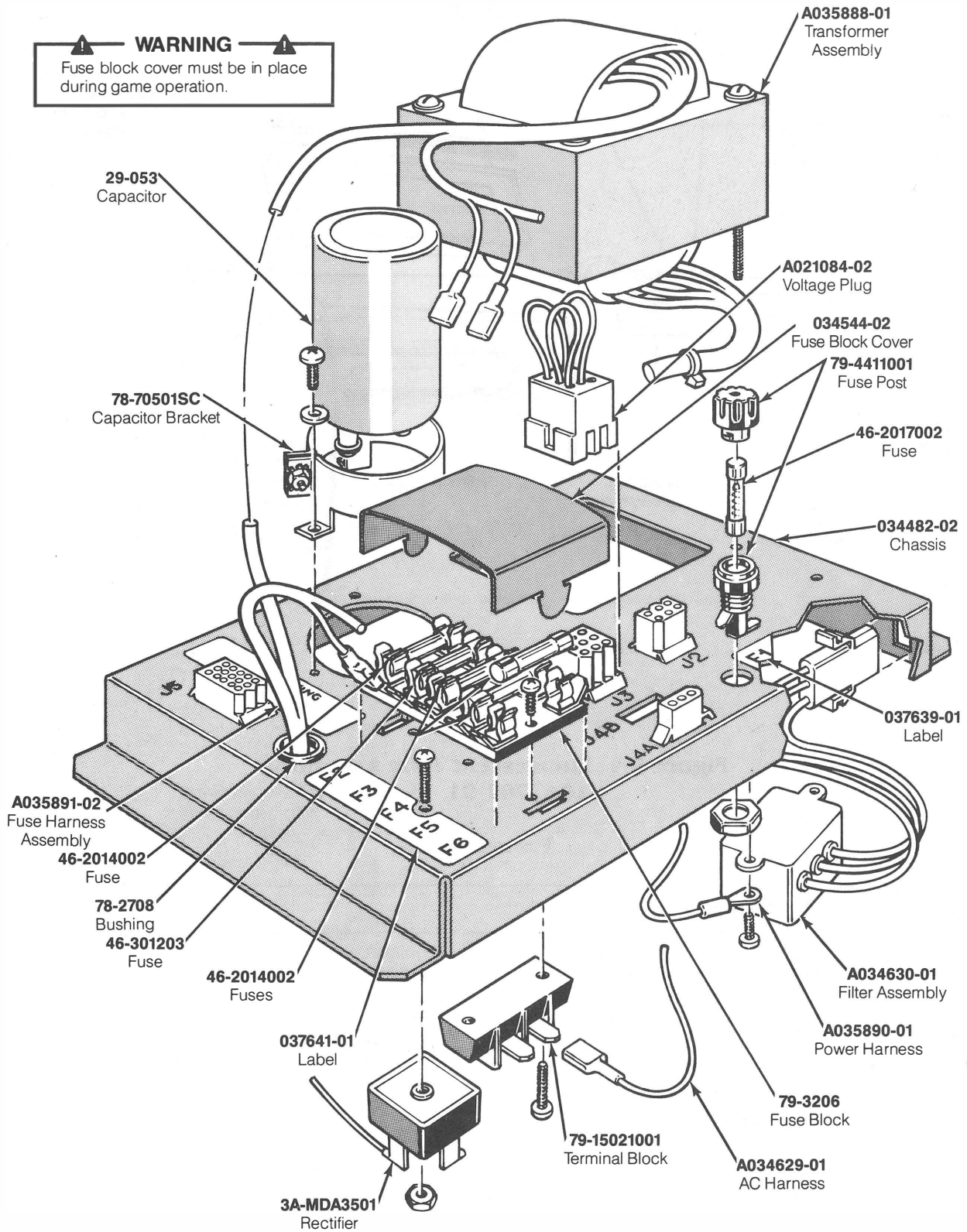

**Figure 5-5 Power Supply Assembly
A037671-16 J**

Power Supply Assembly Parts List

Designator	Description	Part No.
C1	27,000 μ F, 15 VDC Electrolytic Capacitor	29-053
C1	2-Inch Capacitor Mounting Bracket	78-70501SC
CR1	Type-MDA3501 Bridge Rectifier	3A-MDA3501
F1	Fuse Label (U.S.)	037639-01
F1	Fuse Label (European)	037639-02
F1	4 A, 250 V, 3AG Slow-Blow Glass Cartridge-Type Fuse (Acceptable substitute is part no. 46-2014001)	46-2014002
F1	7 A, 250 V, 3AG Slow-Blow Glass Cartridge-Type Fuse	46-2017002
F1	Panel-Mounting 3AG Cartridge-Type Fuse Holder	79-4411001
F2	5-Position 3AG Fuse Block with $\frac{3}{4}$ -Inch Terminals	79-3206
F2-F6	Fuse Harness Assembly	A035891-02
F2-F6	Fuse Block Cover	034544-02
F2-F6	Fuse Label	037641-02
F3	25 A, 32 V, 3AG Slow-Blow Glass Cartridge-Type Fuse	46-301253
F4	2-Circuit Single-Row Terminal Block	79-15021001
FL1	RFI Filter Assembly	A034630-01
J2	Power Harness Assembly	A035890-01
J3	Voltage Plug Assembly (105-135 VAC—yellow wire)	A021084-02
J3	Voltage Plug Assembly (220 VAC—blue wire, European)	A021084-04
J3	Voltage Plug Assembly (240 VAC—brown wire, European)	A021084-05
J4A, J4B	AC Harness Assembly	A034629-01
T1	Transformer Assembly	A035888-01
	Nylon 6/6 Hole Bushing with $\frac{5}{8}$ -Inch Inside Diameter \times $\frac{55}{64}$ -Inch Outside Diameter	78-2708
	Power Supply Chassis Base	034482-02

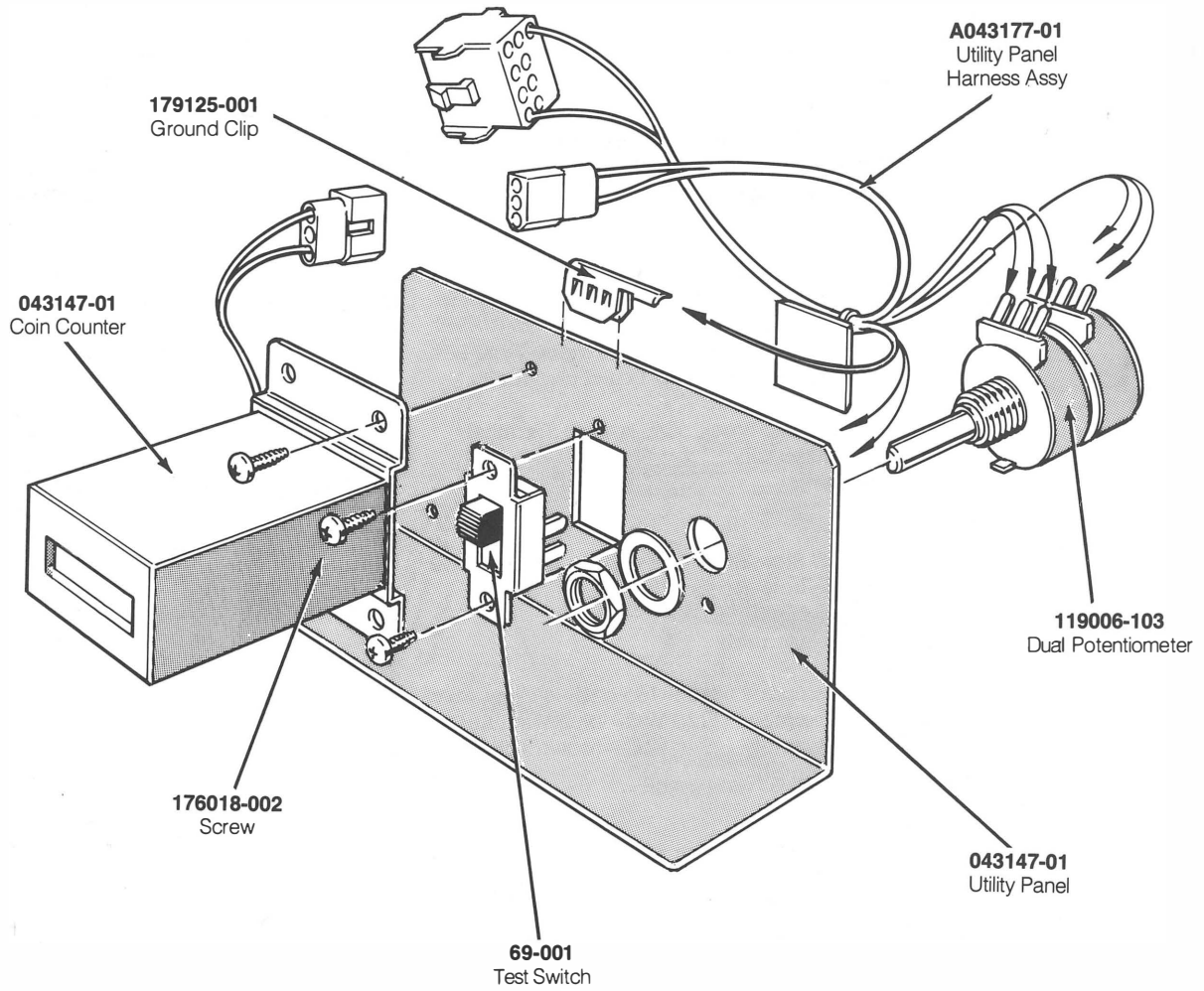

**Figure 5-6 Utility Panel Assembly
A043146-01 A**

Parts List

Part No.	Description
A002465-01	Coin Counter
A043177-01	Utility Panel Harness Assembly
69-001	Double-Pole Double-Throw Test Switch
043147-01	Utility Panel
119006-103	10k Ω Dual Potentiometer
176018-002	#6-32 \times 1/2-Inch Long, Cross-Recessed Pan-Head Thread-Forming Screw
179125-001	Ground Clip

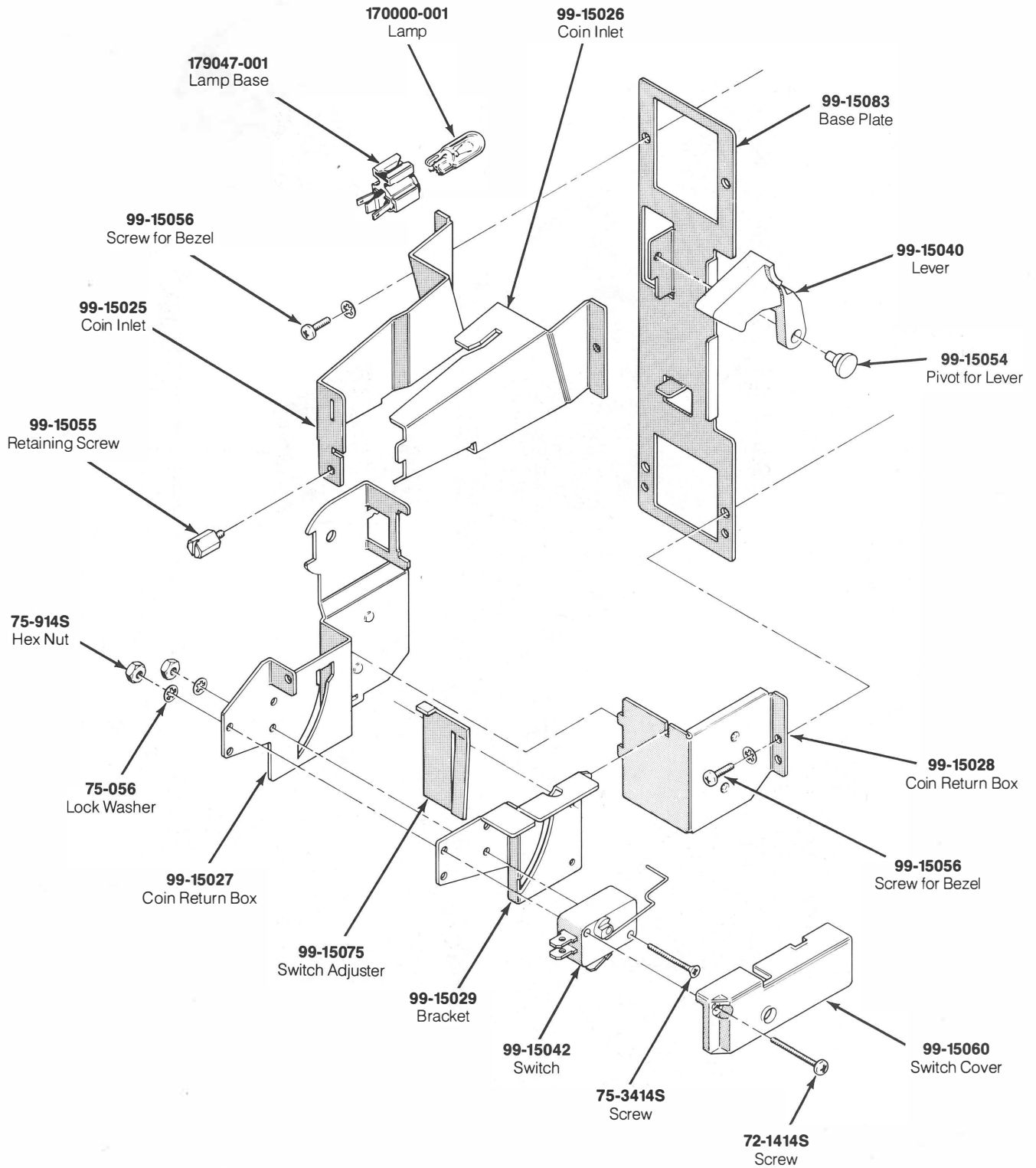

**Figure 5-7 Coin Controls, Inc. Coin Door Assembly
171034-xxx A**

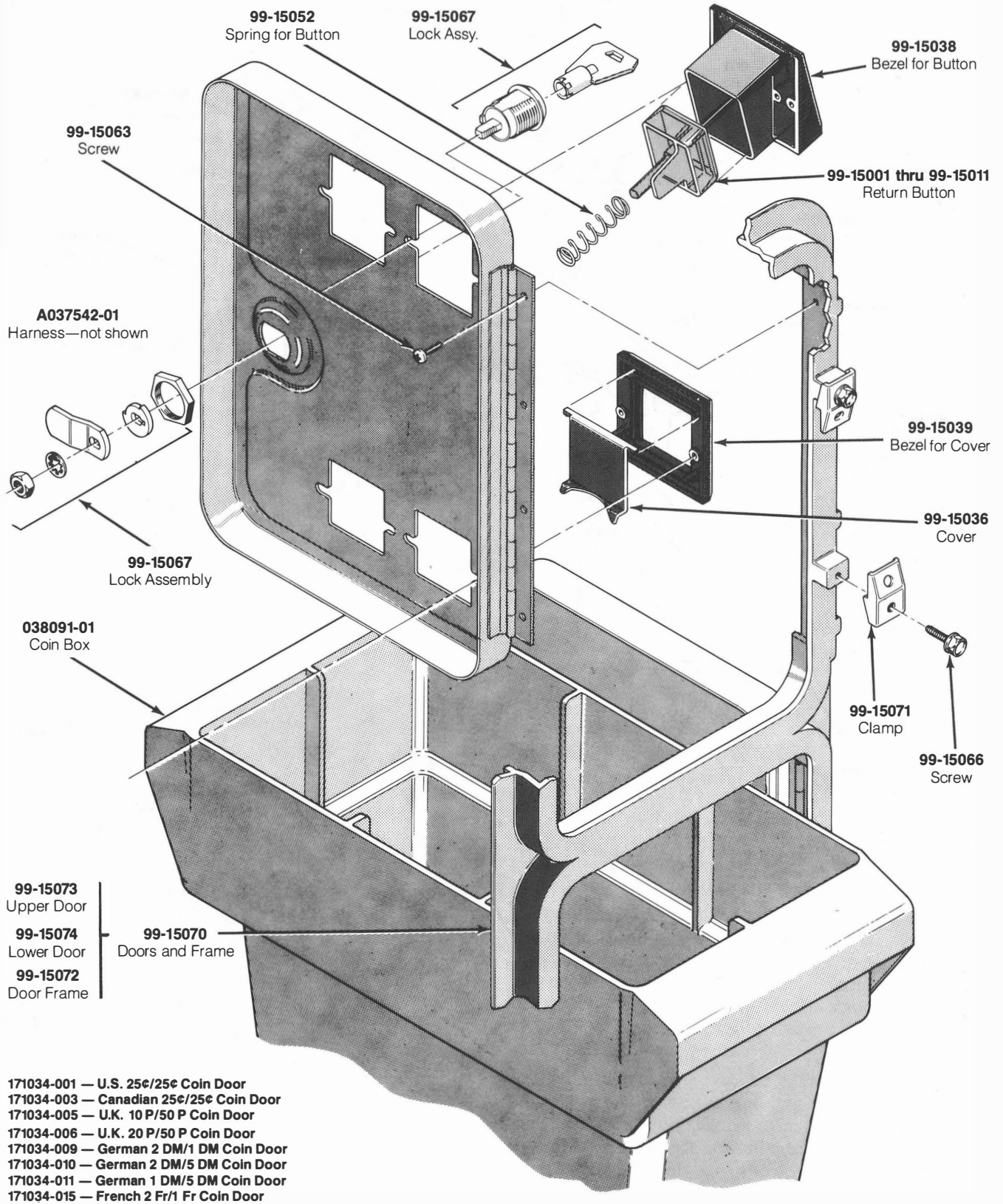
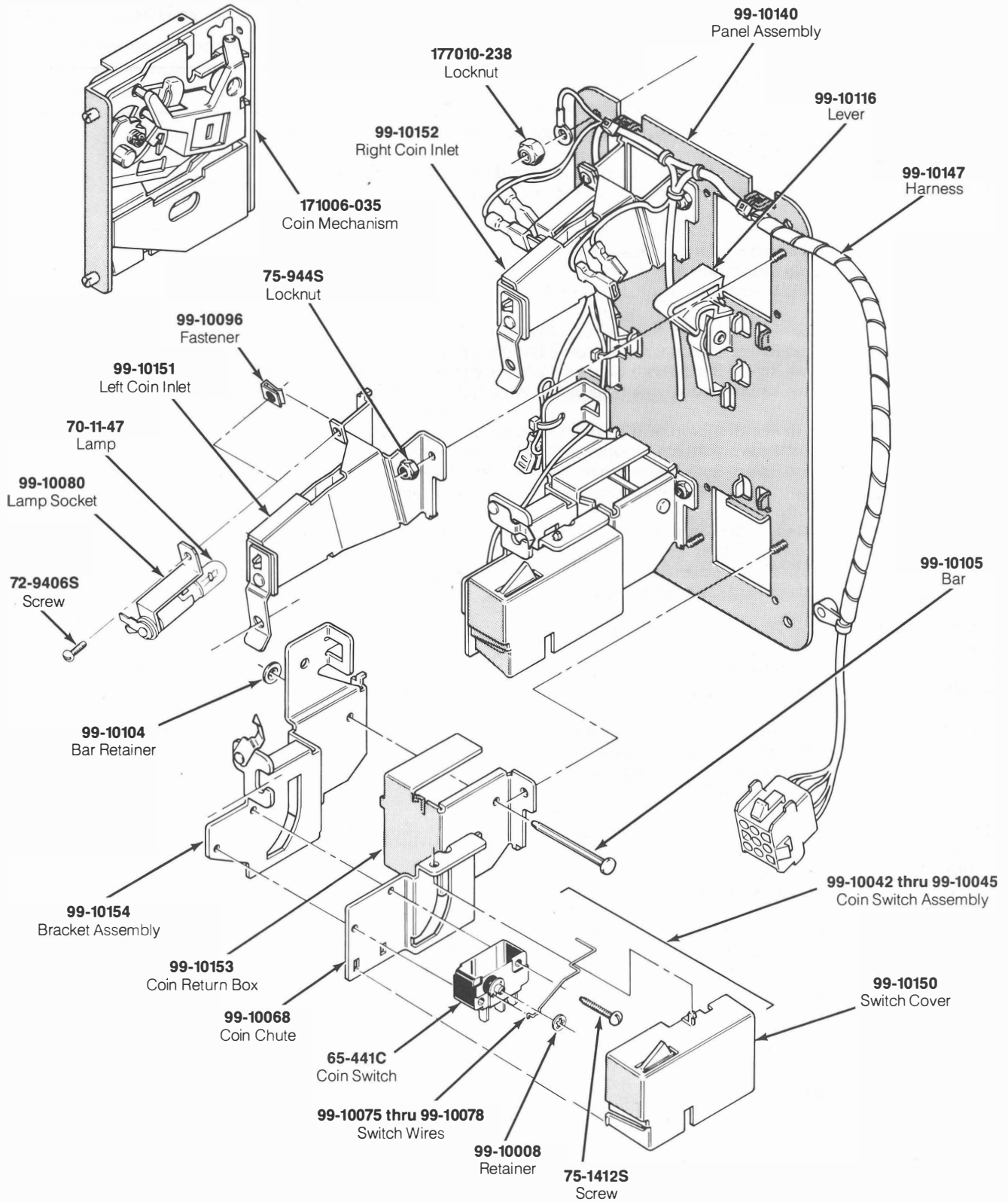

Figure 5-7 Coin Controls, Inc. Coin Door Assembly, continued
 171034-xxx A

Coin Controls, Inc. Coin Door Assembly Parts List

Part No.	Description
A036597-01	Harness Assembly (Ireland-Built cabinet only)
A037542-01	Harness Assembly
72-1414S	#4-40 × 7/8-Inch Cross-Recessed Pan-Head Steel Machine Screw
75-056	#6 Internal-Tooth Zinc-Plated Steel Lock Washer
75-914S	#4-40 Steel Machine Hex Nut
75-3414S	#4-40 × 7/8-Inch 82° Cross-Recessed Flat-Head Steel Machine Screw
99-15001	Coin Return Button with U.S. 25-cent Price Plate
99-15002	Coin Return Button with U.S. \$1 Price Plate
99-15003	Coin Return Button with German 1 DM Price Plate
99-15004	Coin Return Button with German 2 DM Price Plate
99-15005	Coin Return Button with German 5 DM Price Plate
99-15006	Coin Return Button with Belgian 5 Fr Price Plate
99-15007	Coin Return Button with French 1 Fr Price Plate
99-15008	Coin Return Button with Japanese 100 Yen Price Plate
99-15009	Coin Return Button with British 10 Pence Price Plate
99-15010	Coin Return Button with Australian 20-cent Price Plate
99-15011	Coin Return Button with Italian 100 Lire Price Plate
99-15025	Left Half of Coin Inlet
99-15026	Right Half of Coin Inlet
99-15027	Side Plate of Coin Return Box
99-15028	Base Plate of Coin Return Box
99-15029	Switch Bracket
99-15036	Metal Coin Return Cover
99-15038	Bezel for Coin Return Button
99-15039	Metal Bezel for Coin Return Button
99-15042	Coin Switch for U.S. 25 cents
99-15052	Spring for Coin Return Button
99-15055	Retaining Screw
99-15056	#4-40 × 5/16-Inch Cross-Recessed Pan-Head Steel Machine Screw
99-15060	Switch Cover
99-15063	Screw for Hinge
99-15066	Screw for Clamp
99-15067	Lock Assembly
99-15070	Doors and Frame
99-15071	Clamp for Frame
99-15072	Door Frame
99-15073	Upper Door
99-15074	Lower Door
99-15075	Switch Adjuster
99-15083	Base Plate—includes:
99-15040	Lever
99-15054	Pivot for Lever
038091-01	Coin Box—not included in assembly (Acceptable substitute is part no. A037491-01)
170000-001	6.3 V Miniature Wedge-Base Incandescent Lamp
171006-035	Metal Coin Mechanism
171050-001	Dual Entry Face Plate
179047-001	Lamp Base



**Figure 5-8 Coin Acceptors, Inc. Coin Door Assembly
171027-001 A**

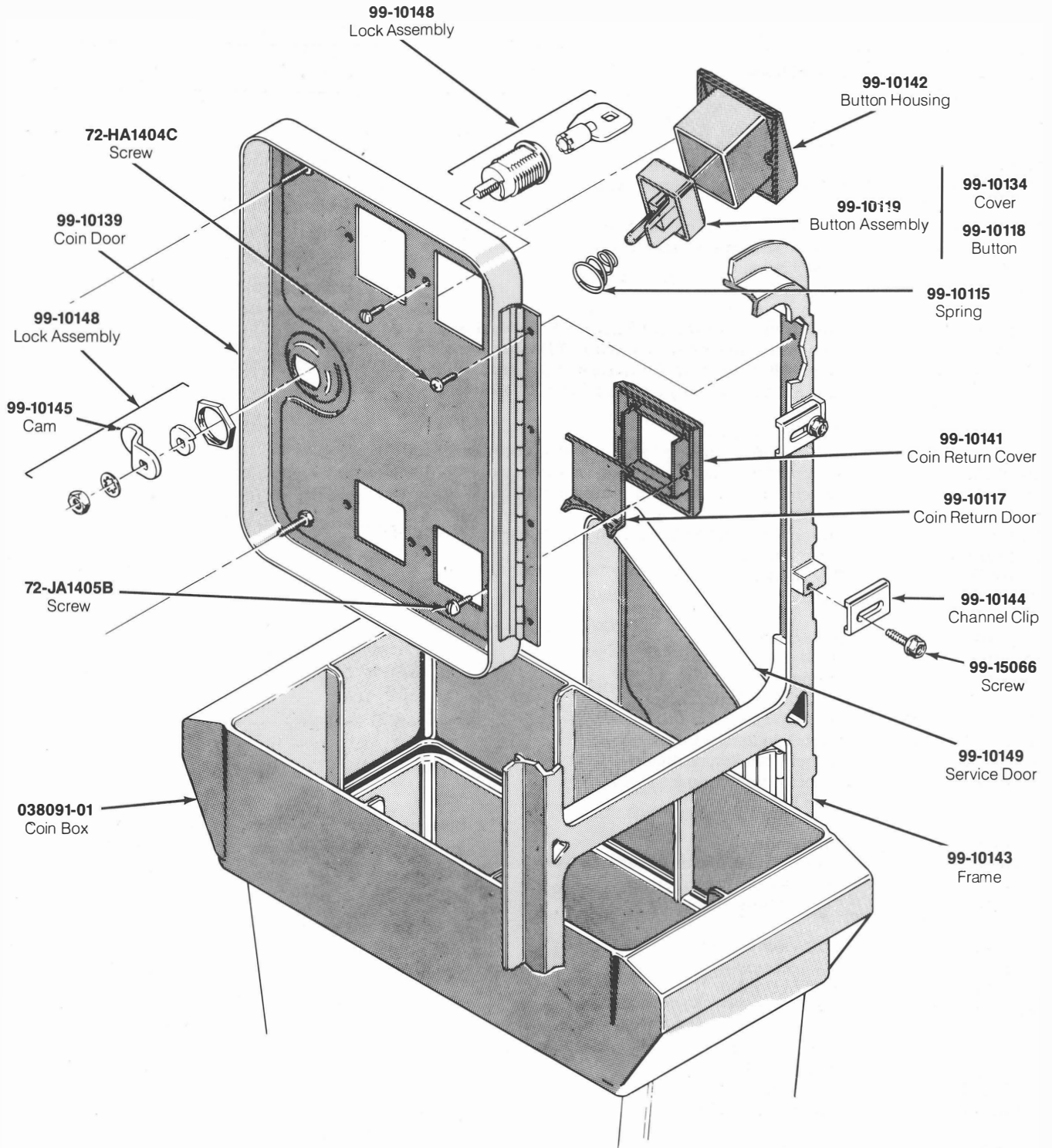

Figure 5-8' Coin Acceptors, Inc. Coin Door Assembly, continued
171027-001 A

Coin Acceptors, Inc. Coin Door Assembly Parts List

Part No.	Description
65-441C	Coin Switch
70-11-47	Miniature Bayonet Lamp
72-9406S	#4-40 × 3/8-Inch Truss-Head Screw
72-HA1404C	#4-40 × 1/4-Inch Pan-Head Screw
72-JA1405B	#4-40 × .31-Inch Pan-Head Screw
75-1412S	#4-40 × 3/4-Inch Pan-Head Screw
75-994S	#4-40 Locknut
99-10008	Retainer
99-10042	Coin Switch Assembly for Belgian 5 Fr and U.S. \$.25
99-10043	Coin Switch Assembly for German 1 DM, Japanese 100 Yen, Swiss 1 Fr
99-10044	Coin Switch Assembly for German 2 DM, Italian 100 L, U.S. \$1.00
99-10045	Coin Switch Assembly for Australian \$.20, German 5 DM, British 10 P
99-10068	Coin Return Chute
99-10075	Switch Wire (included in coin switch assembly 99-10043)
99-10076	Switch Wire (included in coin switch assembly 99-10042)
99-10077	Switch Wire (included in coin switch assembly 99-10044)
99-10078	Switch Wire (included in coin switch assembly 99-10045)
99-10080	Lamp Socket
99-10081	Key Holder
99-10096	Fastener
99-10104	Bar Retainer
99-10105	Bar
99-10115	Spring
99-10116	Plastic Coin Return Lever
99-10117	Steel Coin Return Door
99-10118	Amber Coin Return Button
99-10119	Amber Coin Button for U.S. \$.25
99-10134	Coin Button Cover
99-10139	Coin Door
99-10140	Coin Door Inner-Panel Assembly
99-10141	Die-cast Coin Return Cover
99-10142	Die-cast Button Housing
99-10143	Coin Door Frame
99-10148	Lock Assembly
99-10149	Service Door
99-10150	Switch Cover
99-10151	Left Coin Inlet
99-10152	Right Coin Inlet
99-10153	Coin Return Box
99-10154	Bracket Assembly
99-15066	Screw for Clamp
171006-035	Metal Coin Mechanism for U.S. \$.25

N

O

T

E

S



NOTE

The Federal Communications Commission requires that the game PCBs be housed in the EMI cage with the EMI Shield PCB attached.

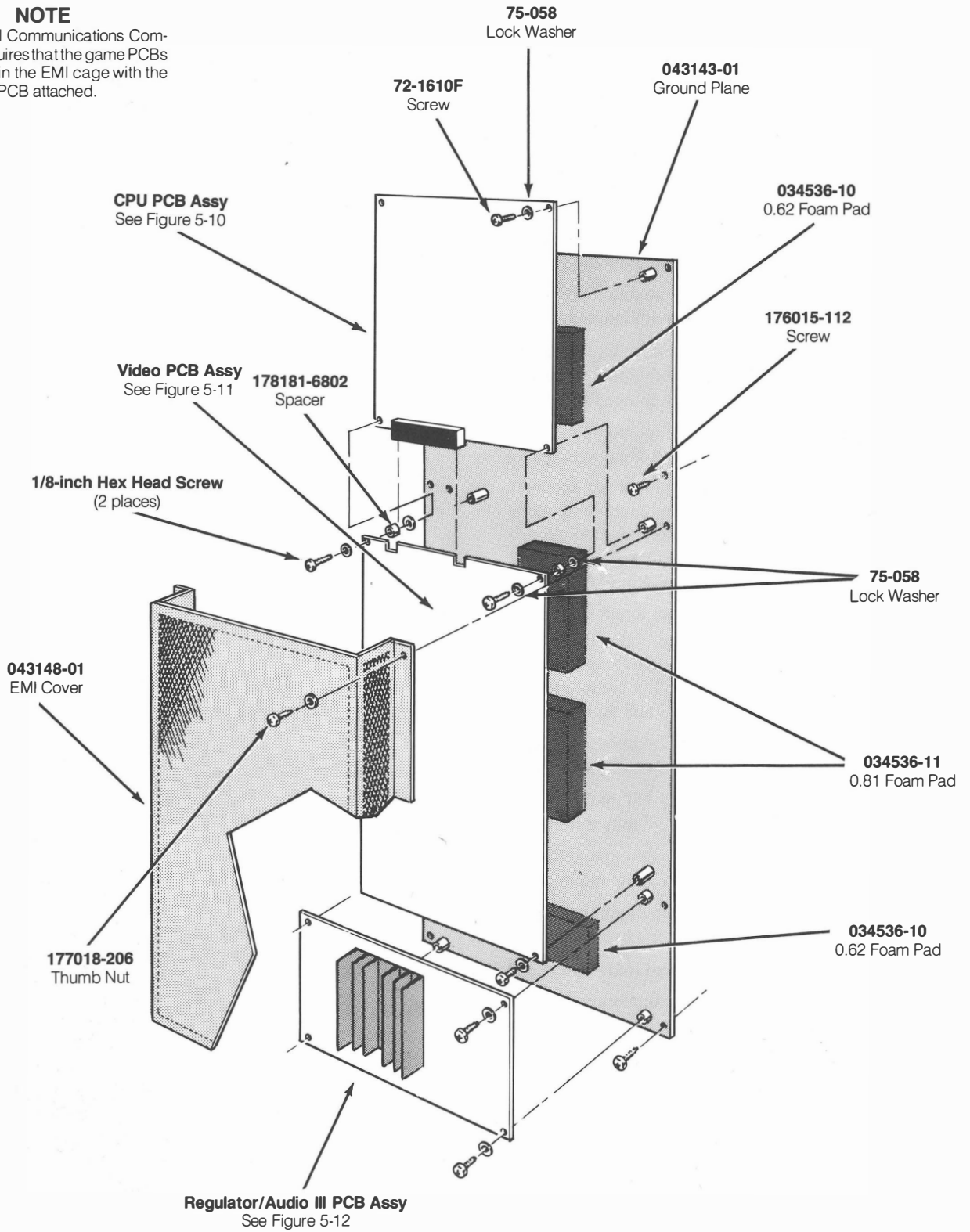
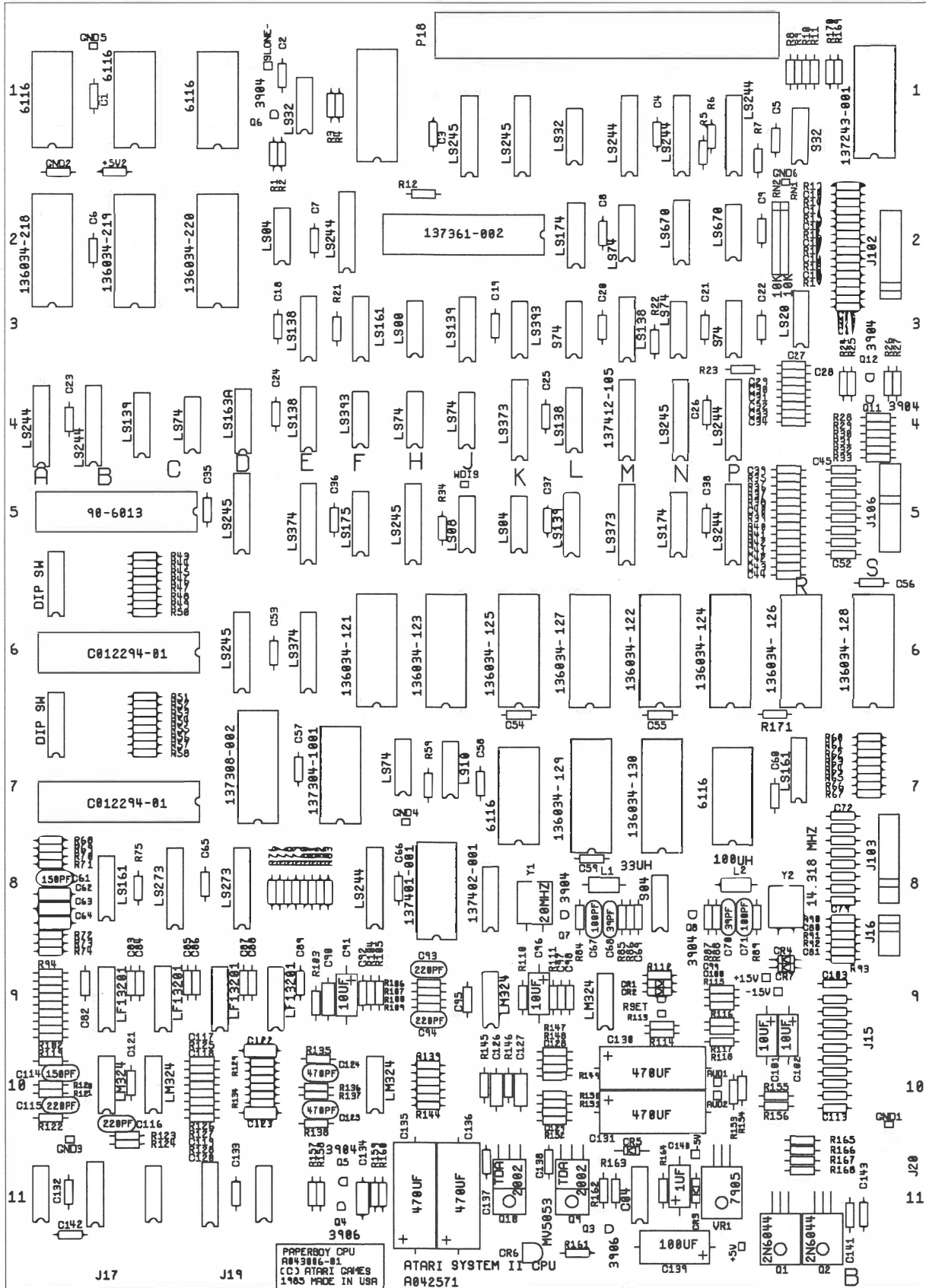

Figure 5-9 Printed-Circuit Board Mounting Hardware

Printed-Circuit Board Mounting Hardware Parts List

Part No.	Description
A042037-01	Video Printed-Circuit Board Assembly
A042571-01	CPU Printed-Circuit Board Assembly
72-1610F	#6-32 × 5/8-Inch Pan-Head Screw
72-6816S	#8 × 1-Inch Cross-Recessed Pan-Head Screw
75-058	#8 Internal Tooth Lock Washer
034536-10	0.62-Inch Thick Foam Pad
034536-11	0.81-Inch Thick Foam Pad
043143-01	Ground Plane
043148-01	EMI Cover
176015-112	10 × 3/4-Inch Cross-Recessed Pan-Head Screw
177018-206	#6-32 Knurled Brass Thumb Nut
178181-6802	Round Spacer



NOTICE TO ALL PERSONS RECEIVING THIS DRAWING
 CONFIDENTIAL: Reproduction forbidden without the specific written permission of Atari Games Corporation, Sunnyvale, CA. This drawing is only conditionally issued, and neither receipt nor possession thereof conveys or transfers any right in, or license to use, the subject matter of the drawing or any design or technical information shown thereon, nor any right to reproduce this drawing or any part thereof. Except for manufacture by vendors of Atari Games Corporation, and for manufacture under the corporation's written license, no right is granted to reproduce this drawing or the subject matter thereof, unless by written agreement with or written permission from the corporation.

Figure 5-10 Central Processing Unit PCB Assembly
 A042571-01 C

Central Processing Unit PCB Assembly Parts List

Designator	Description	Part No.
Capacitors		
C1-C60	0.1, 25 V Ceramic Capacitor	122006-104
C61	150 pF, 100 V Mica Capacitor	128002-151
C62-C64	0.22, 25 V Ceramic Capacitor	122004-224
C65, C66	0.1, 25 V Ceramic Capacitor	122006-104
C67	100 pF, 50 V Mica Capacitor	128002-101
C68	39 pF, 100 V Mica Capacitor	128002-390
C69	0.1, 25 V Ceramic Capacitor	122006-104
C70	39 pF, 100 V Mica Capacitor	128002-390
C71	100 pF, 50 V Mica Capacitor	128002-101
C72-C79	0.01, 25 V Ceramic Capacitor	122005-103
C80, C81	0.001, 50 V Ceramic Capacitor	122002-102
C82-C80	0.1, 25 V Ceramic Capacitor	122006-104
C90	0.22, 25 V Ceramic Capacitor	121002-224
C91	10 μ F, 20 V Tantalum Capacitor	29-046
C92	0.01, 25 V Ceramic Capacitor	122005-103
C93, C94	220 pF, 100 V Mica Capacitor	128002-221
C95	0.0027 μ F, 50 V Ceramic Capacitor	122015-272
C96	10 μ F, 20 V Tantalum Capacitor	29-046
C97	0.0027 μ F, 50 V Ceramic Capacitor	122015-272
C98-C100	0.1, 25 V Ceramic Capacitor	122006-104
C101, C102	10 μ F, 35 V Aluminum Capacitor	24-350106
C103-C109	0.1, 25 V Ceramic Capacitor	122006-104
C110, C111	0.01, 25 V Ceramic Capacitor	122005-103
C112, C113	0.1, 25 V Ceramic Capacitor	122006-104
C114	150 pF, 100 V Mica Capacitor	128002-151
C115, C116	220 pF, 100 V Mica Capacitor	128002-221
C117	0.01, 25 V Ceramic Capacitor	122005-103
C118, C119	0.001, 50 V Ceramic Capacitor	122002-102
C120	0.01, 25 V Ceramic Capacitor	122005-103
C121	0.1, 25 V Ceramic Capacitor	122006-104
C122, C123	0.22, 25 V Ceramic Capacitor	121002-224
C124, C125	470 pF, 100 V Mica Capacitor	128002-471
C126, C127	0.22, 25 V Ceramic Capacitor	121002-224
C128, C129	0.1, 25 V Ceramic Capacitor	122006-104
C130, C131	470 μ F, 25 V Aluminum Capacitor	24-250477
C132	0.1, 25 V Ceramic Capacitor	122006-104
C134	0.22, 25 V Ceramic Capacitor	121002-224
C135, C136	470 μ F, 25 V Aluminum Capacitor	24-250477
C137, C138	0.1, 25 V Ceramic Capacitor	122006-104
C139	100 μ F, 35 V Aluminum Capacitor	24-350107
C140	1 μ F, 50 V Aluminum Capacitor	24-500105
C141	0.1, 25 V Ceramic Capacitor	122006-104
C143	0.1, 25 V Ceramic Capacitor	122006-104
Connectors		
J15	17-Contact Header Connector	179118-017
J16	5-Contact Header Connector	179118-005
J20	9-Contact Header Connector	179014-009
J102	11-Contact Header Connector	179118-011

Central Processing Unit PCB Assembly Parts List, continued

Designator	Description	Part No.
J103	11-Contact Header Connector	179118-011
J106	11-Contact Header Connector	179118-011
P18	80-Contact Card Edge Connector	179221-180
Diodes		
CR1-CR3	Type-1N100 Diode	31-1N100
CR4, CR5	Type-1N4001 Diode	31-1N4001
CR6	MV5053 Light-Emitting Diode	38-MV5053
CR7	Type-1N4001 Diode	31-1N4001
Inductors		
L1	33 μ H Inductor	141016-007
L2	100 μ H Inductor	141002-001
Integrated Circuits		
1A	Type-6116 Integrated Circuit	137211-001
1B/C	Type-6116 Integrated Circuit	137211-001
1D	Type-2804-3 Integrated Circuit	137329-300
1E	Type-74LS32 Integrated Circuit	37-74LS32
1J, 1K	Type-74LS245 Integrated Circuit	37-74LS245
1L	Type-74LS32 Integrated Circuit	37-74LS32
1M, 1N	Type-74LS244 Integrated Circuit	37-74LS244
1P	Type-74LS244 Integrated Circuit	37-74LS244
1R	Type-74S32 Integrated Circuit	37-74S32
1S	Type-ADC0809 Integrated Circuit	137243-001
2A	Type-23128-3, 300ns Programmable ROM Integrated Circuit	136034-218
2B/C	Type-23128-3, 300ns Programmable ROM Integrated Circuit	136034-219
2D	Type-23128-3, 300ns Programmable ROM Integrated Circuit	136034-220
2D/E	Type-74LS04 Integrated Circuit	37-74LS04
2F	Type-74LS244 Integrated Circuit	37-74LS244
2J	Type-T11 (DCT11-XA) Integrated Circuit	137361-002
2L	Type-74LS174 Integrated Circuit	37-74LS174
2M	Type-74LS74 Integrated Circuit	37-74LS74
2N	Type-74LS670 Integrated Circuit	37-74LS670
2P	Type-74LS670 Integrated Circuit	37-74LS670
3E	Type-74LS138 Integrated Circuit	137177-001
3F	Type-74LS161 Integrated Circuit	37-74LS161
3H	Type-74LS00 Integrated Circuit	37-74LS00
3J	Type-74LS139 Integrated Circuit	37-74LS139
3K	Type-74LS393 Integrated Circuit	37-74LS393
3L	Type-74S74 Integrated Circuit	37-74S74
3M	Type-74LS138 Integrated Circuit	137177-001
3N	Type-74LS74 Integrated Circuit	37-74LS74
3P	Type-74S74 Integrated Circuit	37-74S74
3R	Type-74LS20 Integrated Circuit	37-74LS20
4A	Type-74LS244 Integrated Circuit	37-74LS244
4A/B	Type-74LS244 Integrated Circuit	37-74LS244
4B/C	Type-74LS139 Integrated Circuit	37-74LS139
4C/D	Type-74LS74 Integrated Circuit	37-74LS74
4D	Type-74LS163A Integrated Circuit	37-74LS163A
4E	Type-74LS138 Integrated Circuit	137177-001

Central Processing Unit PCB Assembly Parts List, continued

Designator	Description	Part No.
4F	Type-74LS393 Integrated Circuit	37-74LS393
4H, 4J	Type-74LS74 Integrated Circuit	37-74LS74
4K	Type-74LS373 Integrated Circuit	37-74LS373
4L	Type-74LS138 Integrated Circuit	137177-001
4M	Custom Integrated Circuit	137412-105
4N	Type-74LS245 Integrated Circuit	37-74LS245
4P	Type-74LS244 Integrated Circuit	37-74LS244
5B	Type-6502A Integrated Circuit	90-6013
5D	Type-74LS245 Integrated Circuit	37-74LS245
5E	Type-74LS374 Integrated Circuit	37-74LS374
5F	Type-74LS175 Integrated Circuit	37-74LS175
5H	Type-74LS245 Integrated Circuit	37-74LS245
5J	Type-74LS08 Integrated Circuit	37-74LS08
5K	Type-74LS04 Integrated Circuit	37-74LS04
5L	Type-74LS139 Integrated Circuit	37-74LS139
5M	Type-74LS373 Integrated Circuit	37-74LS373
5N	Type-74LS174 Integrated Circuit	37-74LS174
5P	Type-74LS244 Integrated Circuit	37-74LS244
6B	Custom Integrated Circuit	C012294-01
6D	Type-74LS245 Integrated Circuit	37-74LS245
6E	Type-74LS374 Integrated Circuit	37-74LS374
6F	Type-23128-3, 300ns Programmable ROM Integrated Circuit	136034-121
6J	Type-23128-3, 300ns Programmable ROM Integrated Circuit	136034-123
6K	Type-23128-3, 300ns Programmable ROM Integrated Circuit	136034-125
6L	Type-23128-3, 300ns Programmable ROM Integrated Circuit	136034-127
6N	Type-23128-3, 300ns Programmable ROM Integrated Circuit	136034-122
6P	Type-23128-3, 300ns Programmable ROM Integrated Circuit	136034-124
6R	Type-23128-3, 300ns Programmable ROM Integrated Circuit	136034-126
6S	Type-23128-3, 300ns Programmable ROM Integrated Circuit	136034-128
7B	Custom Integrated Circuit	C012294-01
7D	Type-TMS5220C Integrated Circuit	137308-002
7F	Leta Integrated Circuit	137304-1001
7H	Type-74LS74 Integrated Circuit	37-74LS74
7J	Type-74LS10 Integrated Circuit	37-74LS10
7K	Type-6116 Integrated Circuit	137211-001
7L	Type-23128-3, 300ns Programmable ROM Integrated Circuit	136034-129
7N	Type-23128-3, 300ns Programmable ROM Integrated Circuit	136034-130
7P	Type-6116 Integrated Circuit	137211-001
7R	Type-74LS161 Integrated Circuit	37-74LS161
8B	Type-74LS161 Integrated Circuit	37-74LS161
8C, 8D	Type-74LS273 Integrated Circuit	37-74S273
8F	Type-74LS244 Integrated Circuit	37-74LS244
8H/J	Type-Y2151 Integrated Circuit	137401-001
8J/K	Type-YM3012 Integrated Circuit	137402-001
8N	Type-74S04 Integrated Circuit	37-74S04
9B-9D	Type-LF13201 Integrated Circuit	137352-001
9D/E	Type-LF13201 Integrated Circuit	137352-001
9J/K	Type-LM324 Integrated Circuit	37-LM324

Central Processing Unit PCB Assembly Parts List, continued

Designator	Description	Part No.
9L/M	Type-LM324 Integrated Circuit	37-LM324
10B	Type-LM324 Integrated Circuit	37-LM324
10C	Type-LM324 Integrated Circuit	37-LM324
10F	Type-LM324 Integrated Circuit	37-LM324
11M	Type-74C04 Integrated Circuit	137309-001
Q9, Q10	Type-TDA2002 Integrated Circuit	137151-002
Resistors		
R1, R2	$\frac{3}{4}$ W, $\pm 5\%$, 10k Ω Resistor	110000-103
R3, R4	$\frac{3}{4}$ W, $\pm 5\%$, 1k Ω Resistor	110000-102
R5-R7	$\frac{3}{4}$ W, $\pm 5\%$, 220 Ω Resistor	110000-221
R8-R11	$\frac{3}{4}$ W, $\pm 5\%$, 4.7k Ω Resistor	110000-472
R12	$\frac{3}{4}$ W, $\pm 5\%$, 1k Ω Resistor	110000-102
R13-R20	$\frac{3}{4}$ W, $\pm 5\%$, 100 Ω Resistor	110000-101
R21-R23	$\frac{3}{4}$ W, $\pm 5\%$, 1k Ω Resistor	110000-102
R24-R27	$\frac{3}{4}$ W, $\pm 5\%$, 4.7k Ω Resistor	110000-472
R28-R33	$\frac{3}{4}$ W, $\pm 5\%$, 470 Ω Resistor	110000-471
R34	$\frac{3}{4}$ W, $\pm 5\%$, 10k Ω Resistor	110000-103
R35	$\frac{3}{4}$ W, $\pm 5\%$, 1k Ω Resistor	110000-102
R36, R37	$\frac{3}{4}$ W, $\pm 5\%$, 220 Ω Resistor	110000-221
R38-R42	$\frac{3}{4}$ W, $\pm 5\%$, 1k Ω Resistor	110000-102
R43-R58	$\frac{3}{4}$ W, $\pm 5\%$, 10k Ω Resistor	110000-103
R59	$\frac{3}{4}$ W, $\pm 5\%$, 1k Ω Resistor	110000-102
R60-R67	$\frac{3}{4}$ W, $\pm 5\%$, 3.3k Ω Resistor	110000-332
R68	$\frac{3}{4}$ W, $\pm 5\%$, 1k Ω Resistor	110000-102
R69	$\frac{3}{4}$ W, $\pm 5\%$, 1.8k Ω Resistor	110000-182
R70	$\frac{3}{4}$ W, $\pm 5\%$, 100k Ω Resistor	110000-104
R71	$\frac{3}{4}$ W, $\pm 5\%$, 220k Ω Resistor	110000-224
R72-R74	$\frac{3}{4}$ W, $\pm 5\%$, 100k Ω Resistor	110000-104
R75	$\frac{3}{4}$ W, $\pm 5\%$, 1k Ω Resistor	110000-102
R76-R85	$\frac{3}{4}$ W, $\pm 5\%$, 10k Ω Resistor	110000-103
R86, R87	$\frac{3}{4}$ W, $\pm 5\%$, 220 Ω Resistor	110000-221
R88, R89	$\frac{3}{4}$ W, $\pm 5\%$, 10k Ω Resistor	110000-103
R90	$\frac{3}{4}$ W, $\pm 5\%$, 100 Ω Resistor	110000-101
R91	$\frac{3}{4}$ W, $\pm 5\%$, 4.7k Ω Resistor	110000-472
R92	$\frac{3}{4}$ W, $\pm 5\%$, 100 Ω Resistor	110000-101
R93	$\frac{3}{4}$ W, $\pm 5\%$, 4.7k Ω Resistor	110000-472
R94	$\frac{3}{4}$ W, $\pm 5\%$, 22k Ω Resistor	110000-223
R95	$\frac{3}{4}$ W, $\pm 5\%$, 47k Ω Resistor	110000-473
R96	$\frac{3}{4}$ W, $\pm 5\%$, 100k Ω Resistor	110000-104
R97	$\frac{3}{4}$ W, $\pm 5\%$, 22k Ω Resistor	110000-223
R98	$\frac{3}{4}$ W, $\pm 5\%$, 47k Ω Resistor	110000-473
R99	$\frac{3}{4}$ W, $\pm 5\%$, 100k Ω Resistor	110000-104
R100	$\frac{3}{4}$ W, $\pm 5\%$, 22k Ω Resistor	110000-223
R101	$\frac{3}{4}$ W, $\pm 5\%$, 47k Ω Resistor	110000-473
R102, R103	$\frac{3}{4}$ W, $\pm 5\%$, 100k Ω Resistor	110000-104
R104, R105	$\frac{3}{4}$ W, $\pm 5\%$, 1k Ω Resistor	110000-102

Central Processing Unit PCB Assembly Parts List, continued

Designator	Description	Part No.
R107	$\frac{3}{4}$ W, $\pm 5\%$, 18k Ω Resistor	110000-183
R109	$\frac{3}{4}$ W, $\pm 5\%$, 100k Ω Resistor	110000-104
R110	$\frac{3}{4}$ W, $\pm 5\%$, 390 Ω Resistor	110000-391
R111	$\frac{3}{4}$ W, $\pm 5\%$, 560 Ω Resistor	110000-561
R112	$\frac{3}{4}$ W, $\pm 5\%$, 1k Ω Resistor	110000-102
R113	$\frac{3}{4}$ W, $\pm 5\%$, 5.6k Ω Resistor	110000-562
R114	$\frac{3}{4}$ W, $\pm 5\%$, 10 k Ω Resistor	110000-103
R115, R116	$\frac{3}{4}$ W, $\pm 5\%$, 1k Ω Resistor	110000-102
R117, R118	$\frac{3}{4}$ W, $\pm 5\%$, 470 Ω Resistor	110000-471
R119	$\frac{3}{4}$ W, $\pm 5\%$, 220k Ω Resistor	110000-224
R120-R124	$\frac{3}{4}$ W, $\pm 5\%$, 100k Ω Resistor	110000-104
R125	$\frac{3}{4}$ W, $\pm 5\%$, 2.2k Ω Resistor	110000-222
R126, R127	$\frac{3}{4}$ W, $\pm 5\%$, 4.7k Ω Resistor	110000-472
R128	$\frac{3}{4}$ W, $\pm 5\%$, 2.2k Ω Resistor	110000-222
R129	$\frac{3}{4}$ W, $\pm 5\%$, 100k Ω Resistor	110000-104
R131-R133	$\frac{3}{4}$ W, $\pm 5\%$, 100k Ω Resistor	110000-104
R134	$\frac{3}{4}$ W, $\pm 5\%$, 47k Ω Resistor	110000-473
R135-R138	$\frac{3}{4}$ W, $\pm 5\%$, 100k Ω Resistor	110000-104
R139	$\frac{3}{4}$ W, $\pm 5\%$, 47k Ω Resistor	110000-473
R138	$\frac{3}{4}$ W, $\pm 5\%$, 47k Ω Resistor	110000-473
R140	$\frac{3}{4}$ W, $\pm 5\%$, 68k Ω Resistor	110000-683
R141, R142	$\frac{3}{4}$ W, $\pm 5\%$, 47k Ω Resistor	110000-473
R143	$\frac{3}{4}$ W, $\pm 5\%$, 68k Ω Resistor	110000-683
R144	$\frac{3}{4}$ W, $\pm 5\%$, 47k Ω Resistor	110000-473
R145, R146	$\frac{3}{4}$ W, $\pm 5\%$, 4.7k Ω Resistor	110000-472
R147	$\frac{3}{4}$ W, $\pm 5\%$, 10 Ω Resistor	110000-100
R148	$\frac{3}{4}$ W, $\pm 5\%$, 220 Ω Resistor	110000-221
R149	$\frac{3}{4}$ W, $\pm 5\%$, 1 Ω Resistor	110000-010
R150	$\frac{3}{4}$ W, $\pm 5\%$, 10 Ω Resistor	110000-100
R151	$\frac{3}{4}$ W, $\pm 5\%$, 220 Ω Resistor	110000-221
R152	$\frac{3}{4}$ W, $\pm 5\%$, 1 Ω Resistor	110000-010
R153, R154	$\frac{3}{4}$ W, $\pm 5\%$, 1k Ω Resistor	110000-102
R155, R156	$\frac{3}{4}$ W, $\pm 5\%$, 470 Ω Resistor	110000-471
R157	$\frac{3}{4}$ W, $\pm 5\%$, 10k Ω Resistor	110000-103
R158, R159	$\frac{3}{4}$ W, $\pm 5\%$, 3.3k Ω Resistor	110000-332
R160	$\frac{3}{4}$ W, $\pm 5\%$, 1k Ω Resistor	110000-102
R161	$\frac{3}{4}$ W, $\pm 5\%$, 150 Ω Resistor	110000-151
R162	$\frac{3}{4}$ W, $\pm 5\%$, 10k Ω Resistor	110000-103
R163	$\frac{3}{4}$ W, $\pm 5\%$, 3.3k Ω Resistor	110000-332
R164-R168	$\frac{3}{4}$ W, $\pm 5\%$, 1k Ω Resistor	110000-102
R169, R170	$\frac{3}{4}$ W, $\pm 5\%$, 4.7k Ω Resistor	110000-472
R171	$\frac{3}{4}$ W, $\pm 5\%$, 270 Ω Resistor	110000-271
R130	$\frac{3}{4}$ W, $\pm 5\%$, 47k Ω Resistor	110000-473
RN1, RN2	$\frac{1}{8}$ W, 10k \times 8, SIP Resistor	118002-103

Sockets

1A	24-Contact, Medium-Insertion-Force IC Socket	79-42C24
1B/C	24-Contact, Medium-Insertion-Force IC Socket	79-42C24
1D	24-Contact, Medium-Insertion-Force IC Socket	79-42C24
1F	28-Contact, Medium-Insertion-Force IC Socket	79-42C28

Central Processing Unit PCB Assembly Parts List, continued

Designator	Description	Part No.
1S	28-Contact, Medium-Insertion-Force IC Socket	79-42C28
2A	28-Contact, Medium-Insertion-Force IC Socket	79-42C28
2B/D	28-Contact, Medium-Insertion-Force IC Socket	79-42C28
2D	28-Contact, Medium-Insertion-Force IC Socket	79-42C28
2J	40-Contact, Medium-Insertion-Force IC Socket	79-42C40
4M	20-Contact, Medium-Insertion-Force IC Socket	79-42C20
5B	40-Contact, Medium-Insertion-Force IC Socket	79-42C40
6B	40-Contact, Medium-Insertion-Force IC Socket	79-42C40
6F	28-Contact, Medium-Insertion-Force IC Socket	79-42C28
6J-6L	28-Contact, Medium-Insertion-Force IC Socket	79-42C28
6N	28-Contact, Medium-Insertion-Force IC Socket	79-42C28
6P	28-Contact, Medium-Insertion-Force IC Socket	79-42C28
6R, 6S	28-Contact, Medium-Insertion-Force IC Socket	79-42C28
7B	40-Contact, Medium-Insertion-Force IC Socket	79-42C40
7D	28-Contact, Medium-Insertion-Force IC Socket	79-42C28
7F	24-Contact, Medium-Insertion-Force IC Socket	79-42C24
7K	24-Contact, Medium-Insertion-Force IC Socket	79-42C24
7L	28-Contact, Medium-Insertion-Force IC Socket	79-42C28
7N	28-Contact, Medium-Insertion-Force IC Socket	79-42C28
7P	24-Contact, Medium-Insertion-Force IC Socket	79-42C24
8H/J	24-Contact, Medium-Insertion-Force IC Socket	79-42C24
8J/K	16-Contact, Medium-Insertion-Force IC Socket	79-42C16
Transistors		
Q1, Q2	Type-2N6044 Transistor	33-2N6044
Q3, Q4	Type-2N3906 Transistor	33-2N3906
Q5-Q7	Type-2N3904 Transistor	34-2N3904
Q11, Q12	Type-2N3904 Transistor	34-2N3904
Miscellaneous		
VR1	Type-7905 Voltage Regulator	37-7905
Y1	20 MHz Crystal	144000-003
Y2	14.318 MHz Crystal	90-101

N O T E S

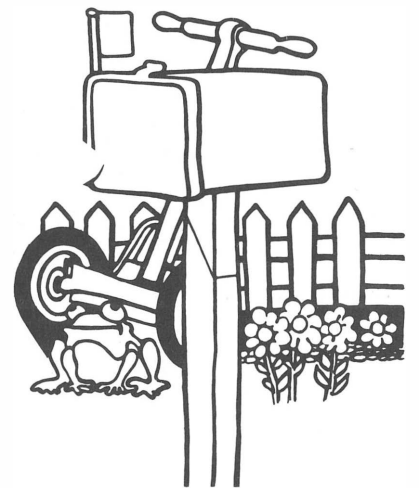

Video PCB Assembly Parts List

Designator	Description	Part No.
2A	Type-6116P-3 150ns RAM Integrated Circuit	137211-001
2B/C	Type-6116P-3 150ns RAM Integrated Circuit	137211-001
2C/D	Type-6116P-3 150ns RAM Integrated Circuit	137211-001
2E	Type-6116P-3 150ns RAM Integrated Circuit	137211-001
3A	Type-6116P-3 150ns RAM Integrated Circuit	137211-001
3B/C	Type-6116P-3 150ns RAM Integrated Circuit	137211-001
3C/D	Type-6116P-3 150ns RAM Integrated Circuit	137211-001
3E	Type-6116P-3 150ns RAM Integrated Circuit	137211-001
3N	Type-6116P-3 150ns RAM Integrated Circuit	137211-001
3P/R	Type-6116P-3 150ns RAM Integrated Circuit	137211-001
3R/S	Type-6116P-3 150ns RAM Integrated Circuit	137211-001
3T	Type-6116P-3 150ns RAM Integrated Circuit	137211-001
6A	Type-23256 200ns Programmable ROM Integrated Circuit	136034-116
6B	Type-23128 200ns Programmable ROM Integrated Circuit	136034-106
6C	Type-23256 200ns Programmable ROM Integrated Circuit	136034-115
6D/E	Type-23128 200ns Programmable ROM Integrated Circuit	136034-103
6F/H	Type-23256 200ns Programmable ROM Integrated Circuit	136034-114
6H/J	Type-23256 200ns Programmable ROM Integrated Circuit	136034-113
6K	Type-23256 200ns Programmable ROM Integrated Circuit	136034-112
6L	Type-23256 200ns Programmable ROM Integrated Circuit	136034-111
6M	Type-23256 200ns Programmable ROM Integrated Circuit	136034-110
6N	Type-23256 200ns Programmable ROM Integrated Circuit	136034-109
6P/R	Type-23256 200ns Programmable ROM Integrated Circuit	136034-108
6R/S	Type-23256 200ns Programmable ROM Integrated Circuit	136034-107
6T	Type-2364 200ns Programmable ROM Integrated Circuit	136034-117
Capacitors		
C1, C2	100 μ F, 35 V Aluminum Capacitor	24-350107
C3	0.1 μ F, 50 V Ceramic Capacitor	122002-104
C4	0.1 μ F, 50 V Ceramic Capacitor	122002-104
C5	100 μ F, 35 V Aluminum Capacitor	24-350107
C7	1 μ F, 50 V Electrolytic Capacitor	24-500105
C8	0.1 μ F, 50 V Ceramic Capacitor	122002-104
C9	47 pF, 100 V Mica Capacitor	128002-470
C10	68 pF, 100 V Mica Capacitor	128002-680
C11-C13	0.1 μ F, 50 V Ceramic Capacitor	122002-104
C14	0.001 μ F, 50 V Ceramic Capacitor	122002-102
C15	0.1 μ F, 50 V Ceramic Capacitor	122002-104
C16	0.001 μ F, 50 V Ceramic Capacitor	122002-102
C17	0.1 μ F, 50 V Ceramic Capacitor	122002-104
C19-C138	0.1 μ F, 50 V Ceramic Capacitor	122002-104
C139-C141	0.001 μ F, 50 V Ceramic Capacitor	122002-102
C142	0.1 μ F, 50 V Ceramic Capacitor	122002-104
C144-C147	0.1 μ F, 50 V Ceramic Capacitor	122002-104
Diode		
CR1	MV5053 Light-Emitting Diode	38-MV5053
Connectors		
J13	11-Contact Header Connector	179014-011
J19	11-Contact, Square-Pin Header Connector	179118-011

Video PCB Assembly Parts List, continued

Designator	Description	Part No.
Inductors		
L1-L4	1 μ H Inductor	141007-001
L5	100 μ H Inductor	141019-001
Integrated Circuits		
1A-1C	Type-74LS157 Integrated Circuit	37-74LS157
1D-1F	Type-74LS244 Integrated Circuit	37-74LS244
1H	Type-74LS244 Integrated Circuit	37-74LS244
1J	Type-74LS374 Integrated Circuit	37-74LS374
1K	Type-74LS32 Integrated Circuit	37-74LS32
1L, 1M	Type-74LS243 Integrated Circuit	37-74LS245
1N	Type-74LS244 Integrated Circuit	37-74LS244
1P	Type-74LS244 Integrated Circuit	37-74LS244
1R, 1S	Type-74LS244 Integrated Circuit	37-74LS244
1T	Type-74S74 Integrated Circuit	37-74S74
2F	Type-74LS139 Integrated Circuit	37-74LS139
2H	Type-74LS244 Integrated Circuit	37-74LS244
2H/J	Type-74LS374 Integrated Circuit	37-74LS374
2J/K	Type-74LS32 Integrated Circuit	37-74LS32
2K/L	Type-74LS174 Integrated Circuit	37-74LS174
2L	Type-74S74 Integrated Circuit	37-74S74
2M	Type-74LS139 Integrated Circuit	37-74LS139
2N	Type-74LS374 Integrated Circuit	37-74LS374
2P	Type-74LS374 Integrated Circuit	37-74LS374
2R, 2S	Type-74LS374 Integrated Circuit	37-74LS374
2T	Type-74S32 Integrated Circuit	37-74S32
3F	Type-74LS153 Integrated Circuit	37-74LS153
3H	Type-74LS153 Integrated Circuit	37-74LS153
3H/J	Type-74LS153 Integrated Circuit	37-74LS153
3J/K	Type-74LS153 Integrated Circuit	37-74LS153
3K/L	Type-74S174 Integrated Circuit	137209-001
3L, 3M	Type-74LS153 Integrated Circuit	37-74LS153
4A-4C	Type-74F374 Integrated Circuit	137420-001
4D, 4E	Type-74LS163A Integrated Circuit	37-74LS163A
4E/F	Type-74S157 Integrated Circuit	37-74S157
4F	Type-74LS273 Integrated Circuit	37-74LS273
4H	Type-74LS273 Integrated Circuit	37-74LS273
4J	Type-74LS163A Integrated Circuit	37-74LS163A
4K	Type-74S74 Integrated Circuit	37-74S74
4L, 4M	Type-74LS273 Integrated Circuit	37-74LS273
4N	Type-74F374 Integrated Circuit	137420-001
4P	Type-74S174 Integrated Circuit	137209-001
4R	Type-74F374 Integrated Circuit	137420-001
4S	Type-74LS273 Integrated Circuit	37-74LS273
4T	Type-74F374 Integrated Circuit	137420-001
5A	Type-74S04 Integrated Circuit	37-74S04
5B	Type-74LS109 Integrated Circuit	37-74LS109
5B/C	Type-74LS08 Integrated Circuit	37-74LS08
5C/D	Type-74S08 Integrated Circuit	37-74S08

Video PCB Assembly Parts List, continued

Designator	Description	Part No.
5D, 5E	Type-74LS163A Integrated Circuit	37-74LS163A
5F	Type-74LS174 Integrated Circuit	37-74LS174
5H	Type-74LS174 Integrated Circuit	37-74LS174
5J	Type-74F163 Integrated Circuit	137345-001
5K	Type-74LS04 Integrated Circuit	37-74LS04
5L, 5M	Type-74LS283 Integrated Circuit	137204-001
5N	Type-74F374 Integrated Circuit	137420-001
5P	Type-82S131 Programmable PROM Integrated Circuit	136034-131
5R	Type-74F374 Integrated Circuit	137420-001
5S	Type-74LS273 Integrated Circuit	37-74LS273
5T	Type-74F374 Integrated Circuit	137420-001
6E/F	Type-74LS163A Integrated Circuit	37-74LS163A
7E/7F	Type-74LS00 Integrated Circuit	37-74LS00
7E/F	Type-74LS32 Integrated Circuit	37-74LS32
7F/H	Type-74S08 Integrated Circuit	37-74S08
7H/J	Type-74LS158 Integrated Circuit	137203-001
7J	Type-74LS158 Integrated Circuit	137203-001
7K	Type-74S194 Integrated Circuit	137424-001
7L	Type-74S194 Integrated Circuit	137424-001
7M	Type-74LS158 Integrated Circuit	137203-001
7N	Type-74LS158 Integrated Circuit	137203-001
7P	Type-74S194 Integrated Circuit	137424-001
7R-7T	Type-74S194 Integrated Circuit	137424-001
8A, 8B	Type-74S194 Integrated Circuit	137424-001
8B/C	Type-74S194 Integrated Circuit	137424-001
8C/D	Type-74S194 Integrated Circuit	137424-001
8D	Type-74F163 Integrated Circuit	137345-001
8E	Type-74LS163A Integrated Circuit	37-74LS163A
8F	Type-74LS74 Integrated Circuit	37-74LS74
8H	Type-74S162 Integrated Circuit	137342-001
8J	Type-74S194 Integrated Circuit	137424-001
8L	Type-74LS20 Integrated Circuit	37-74LS20
8M	Type-74S244 Integrated Circuit	137333-001
8N	Type-2149, 35ns RAM Integrated Circuit	137199-003
8P	Type-2149, 35ns RAM Integrated Circuit	137199-003
8R-8T	Type-74F163 Integrated Circuit	137345-001
9A	Type-74S189 Integrated Circuit	37-74S189
9B	Type-74S158 Integrated Circuit	137312-001
9B/C	Type-74S189 Integrated Circuit	37-74S189
9C/D	Type-74S189 Integrated Circuit	37-74S189
9D	Type-74S189 Integrated Circuit	37-74S189
9E	Type-74S189 Integrated Circuit	37-74S189
9F	Type-74LS04 Integrated Circuit	37-74LS04
9H	Type-74S153 Integrated Circuit	137207-001
9J	Type-74LS244 Integrated Circuit	37-74LS244
9K, 9L	Type-74F374 Integrated Circuit	137420-001
9M	Type-74S244 Integrated Circuit	137333-001
9N	Type-2149, 35ns RAM Integrated Circuit	137199-003
9P	Type-2149, 35ns RAM Integrated Circuit	137199-003
9R-9T	Type-74F163 Integrated Circuit	137345-001

Video PCB Assembly Parts List, continued

Designator	Description	Part No.
10A	Type-74S158 Integrated Circuit	137312-001
10B	Type-74F374 Integrated Circuit	137420-001
10B/C	Type-74S00 Integrated Circuit	37-74S00
10C/D	Type-74S283 Integrated Circuit	137241-001
10D, 10E	Type-74S153 Integrated Circuit	137207-001
10F	Type-74LS244 Integrated Circuit	37-74LS244
10H	Type-74LS244 Integrated Circuit	37-74LS244
10J-10L	Type-74F374 Integrated Circuit	137420-001
10M	Type-74S244 Integrated Circuit	137333-001
10N	Type-2149, 35ns RAM Integrated Circuit	137199-003
10P	Type-2149, 35ns RAM Integrated Circuit	137199-003
10R-10T	Type-74F163 Integrated Circuit	137345-001
11A	Type-74S189 Integrated Circuit	37-74S189
11B	Type-74S158 Integrated Circuit	137312-001
11B/C	Type-74S112 Integrated Circuit	137334-001
11C/D	Type-74S00 Integrated Circuit	37-74S00
11D	Type-74S08 Integrated Circuit	37-74S08
11E	Type-74S153 Integrated Circuit	137207-001
11F	Type-2149 45 ns RAM Integrated Circuit	137199-002
11H	Type-2149 45 ns RAM Integrated Circuit	137199-002
11J, 11K	Type-2149 45 ns RAM Integrated Circuit	137199-002
11L	Type-74S32 Integrated Circuit	37-74S32
11M	Type-74S20 Integrated Circuit	137423-001
11N	Type-74S10 Integrated Circuit	137236-001
11P	Type-74S86 Integrated Circuit	137002-001
11R	Type-74LS32 Integrated Circuit	37-74LS32
11S	Type-74LS08 Integrated Circuit	37-74LS08
11T	Type-74LS32 Integrated Circuit	37-74LS32
12A	Type-74S74 Integrated Circuit	37-74S74
12B	Type-74S10 Integrated Circuit	137236-001
12B/C	Type-74S04 Integrated Circuit	37-74S04
12C/D	Type-74S74 Integrated Circuit	37-74S74
12D	Type-74S20 Integrated Circuit	137423-001
12E	Type-74S174 Integrated Circuit	137209-001
12F	Type-74LS174 Integrated Circuit	37-74LS174
12H-12K	Type-74F374 Integrated Circuit	137420-001
12L	Type-7406 Integrated Circuit	37-7406
13A	Type-74LS74 Integrated Circuit	37-74LS74
13B	Type-74S112 Integrated Circuit	137334-001
13B/C	Type-74LS32 Integrated Circuit	37-74LS32
13C/D	Type-74LS250 Integrated Circuit	137332-001
13D	Type-7407 Integrated Circuit	37-7407
13E	Type-74S174 Integrated Circuit	137209-001
13F	Type-74LS08 Integrated Circuit	37-74LS08
13H	Type-74F374 Integrated Circuit	137420-001
13J	Type-74LS250 Integrated Circuit	137332-001
13K	Type-7406 Integrated Circuit	37-7406
13L	Type-7406 Integrated Circuit	37-7406

Video PCB Assembly Parts List, continued

Designator	Description	Part No.
Resistors		
HSYNC	¼ W, ± 5%, 0 Ω Resistor	110005-001
VSYNC	¼ W, ± 5%, 0 Ω Resistor	110005-001
R1	¼ W, ± 5%, 150 Ω Resistor	110000-151
R2	¼ W, ± 5%, 10k Ω Resistor	110000-103
R4	¼ W, ± 5%, 68 Ω Resistor	110000-680
R17, R18	¼ W, ± 5%, 220 Ω Resistor	110000-221
R19	¼ W, ± 5%, 1k Ω Resistor	110000-102
R20	¼ W, ± 5%, 120 Ω Resistor	110000-121
R21	¼ W, ± 5%, 150 Ω Resistor	110000-151
R22	¼ W, ± 5%, 180 Ω Resistor	110000-181
R23	¼ W, ± 5%, 220 Ω Resistor	110000-221
R24	¼ W, ± 5%, 470 Ω Resistor	110000-471
R25	¼ W, ± 5%, 1k Ω Resistor	110000-102
R26	¼ W, ± 5%, 2 Ω Resistor	110000-202
R27	¼ W, ± 5%, 150 Ω Resistor	110000-151
R28	¼ W, ± 5%, 3.9k Ω Resistor	110000-392
R29	¼ W, ± 5%, 390 Ω Resistor	110000-391
R30	¼ W, ± 5%, 68 Ω Resistor	110000-680
R31	¼ W, ± 5%, 470 Ω Resistor	110000-471
R32	¼ W, ± 5%, 68 Ω Resistor	110000-680
R33	¼ W, ± 5%, 10 Ω Resistor	110000-100
R34	¼ W, ± 5%, 620 Ω Resistor	110000-621
R35	¼ W, ± 5%, 1.2k Ω Resistor	110000-122
R36	¼ W, ± 5%, 2.4k Ω Resistor	110000-242
R37	¼ W, ± 5%, 5.1k Ω Resistor	110000-512
R38	¼ W, ± 5%, 820 Ω Resistor	110000-821
R39	¼ W, ± 5%, 10k Ω Resistor	110000-103
R40	¼ W, ± 5%, 160 Ω Resistor	110000-161
R41	¼ W, ± 5%, 160 Ω Resistor	110000-161
R42	¼ W, ± 5%, 390 Ω Resistor	110000-391
R43	¼ W, ± 5%, 68 Ω Resistor	110000-680
R44	¼ W, ± 5%, 470 Ω Resistor	110000-471
R45	¼ W, ± 5%, 68 Ω Resistor	110000-680
R46	¼ W, ± 5%, 10 Ω Resistor	110000-100
R47	¼ W, ± 5%, 620 Ω Resistor	110000-621
R48	¼ W, ± 5%, 1.2k Ω Resistor	110000-122
R49	¼ W, ± 5%, 2.4k Ω Resistor	110000-242
R50	¼ W, ± 5%, 5.1k Ω Resistor	110000-512
R51	¼ W, ± 5%, 820 Ω Resistor	110000-821
R52	¼ W, ± 5%, 10k Ω Resistor	110000-103
R53	¼ W, ± 5%, 160 Ω Resistor	110000-161
R54	¼ W, ± 5%, 390 Ω Resistor	110000-391
R55	¼ W, ± 5%, 68 Ω Resistor	110000-680
R56	¼ W, ± 5%, 470 Ω Resistor	110000-471
R57	¼ W, ± 5%, 68 Ω Resistor	110000-680
R58	¼ W, ± 5%, 10 Ω Resistor	110000-100
R59	¼ W, ± 5%, 620 Ω Resistor	110000-621
R60	¼ W, ± 5%, 1.2k Ω Resistor	110000-122

Video PCB Assembly Parts List, continued

Designator	Description	Part No.
R61	¼ W, ± 5%, 2.4k Ω Resistor	110000-242
R62	¼ W, ± 5%, 5.1k Ω Resistor	110000-512
R63	¼ W, ± 5%, 820 Ω Resistor	110000-821
R64	¼ W, ± 5%, 10k Ω Resistor	110000-103
R65-R76	¼ W, ± 5%, 1k Ω Resistor	110000-102
R77	¼ W, ± 5%, 0 Ω Resistor	110005-001
R78	¼ W, ± 5%, 220 Ω Resistor	110000-221
R79, R80	¼ W, ± 5%, 270 Ω Resistor	110000-271
RN1	SIP 680 Ω × 7 Resistor	118007-681
RN2	SIP 680 Ω × 7 Resistor	118007-681
Sockets		
2A	24-Contact, Medium-Insertion-Force IC Socket	79-42C24
2B/C	24-Contact, Medium-Insertion-Force IC Socket	79-42C24
2C/D	24-Contact, Medium-Insertion-Force IC Socket	79-42C24
2E	24-Contact, Medium-Insertion-Force IC Socket	79-42C24
3A	24-Contact, Medium-Insertion-Force IC Socket	79-42C24
3B/C	24-Contact, Medium-Insertion-Force IC Socket	79-42C24
3C/D	24-Contact, Medium-Insertion-Force IC Socket	79-42C24
3E	24-Contact, Medium-Insertion-Force IC Socket	79-42C24
3N	24-Contact, Medium-Insertion-Force IC Socket	79-42C24
3P/R	24-Contact, Medium-Insertion-Force IC Socket	79-42C24
3R/S	24-Contact, Medium-Insertion-Force IC Socket	79-42C24
3T	24-Contact, Medium-Insertion-Force IC Socket	79-42C24
6A	28-Contact, Medium-Insertion-Force IC Socket	79-42C28
6B/C	28-Contact, Medium-Insertion-Force IC Socket	79-42C28
6C/D	28-Contact, Medium-Insertion-Force IC Socket	79-42C28
6D/E	28-Contact, Medium-Insertion-Force IC Socket	79-42C28
6F/H	28-Contact, Medium-Insertion-Force IC Socket	79-42C28
6H/J	28-Contact, Medium-Insertion-Force IC Socket	79-42C28
6K-6N	28-Contact, Medium-Insertion-Force IC Socket	79-42C28
6P/R	28-Contact, Medium-Insertion-Force IC Socket	79-42C28
6R/S	28-Contact, Medium-Insertion-Force IC Socket	79-42C28
6T	28-Contact, Medium-Insertion-Force IC Socket	79-42C28
7A	28-Contact, Medium-Insertion-Force IC Socket	79-42C28
7B/C	28-Contact, Medium-Insertion-Force IC Socket	79-42C28
7C/D	28-Contact, Medium-Insertion-Force IC Socket	79-42C28
7D/E	28-Contact, Medium-Insertion-Force IC Socket	79-42C28
Transistors		
Q1, Q2	Type-2N3904 Transistor	34-2N3904
Q3	Type-2N3906 Transistor	33-2N3906
Q4	Type-2N3904 Transistor	34-2N3904
Q5	Type-2N3906 Transistor	33-2N3906
Q6, Q7	Type-2N3904 Transistor	34-2N3904
Q8	Type-2N3906 Transistor	33-2N3906
Q9, Q10	Type-2N3904 Transistor	34-2N3904
Q11	Type-2N3906 Transistor	33-2N3906
Q12	Type-2N3904 Transistor	34-2N3904
Miscellaneous		
Y1	32 MHz Crystal	144003-002

N O T E S

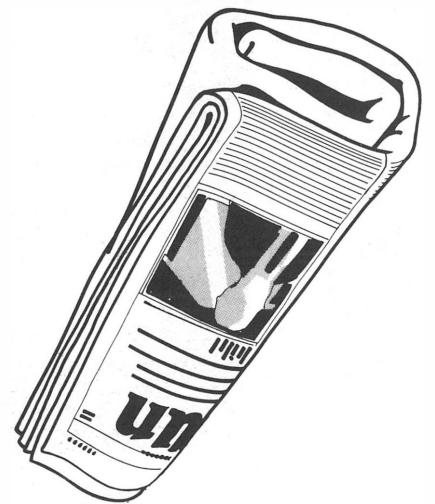

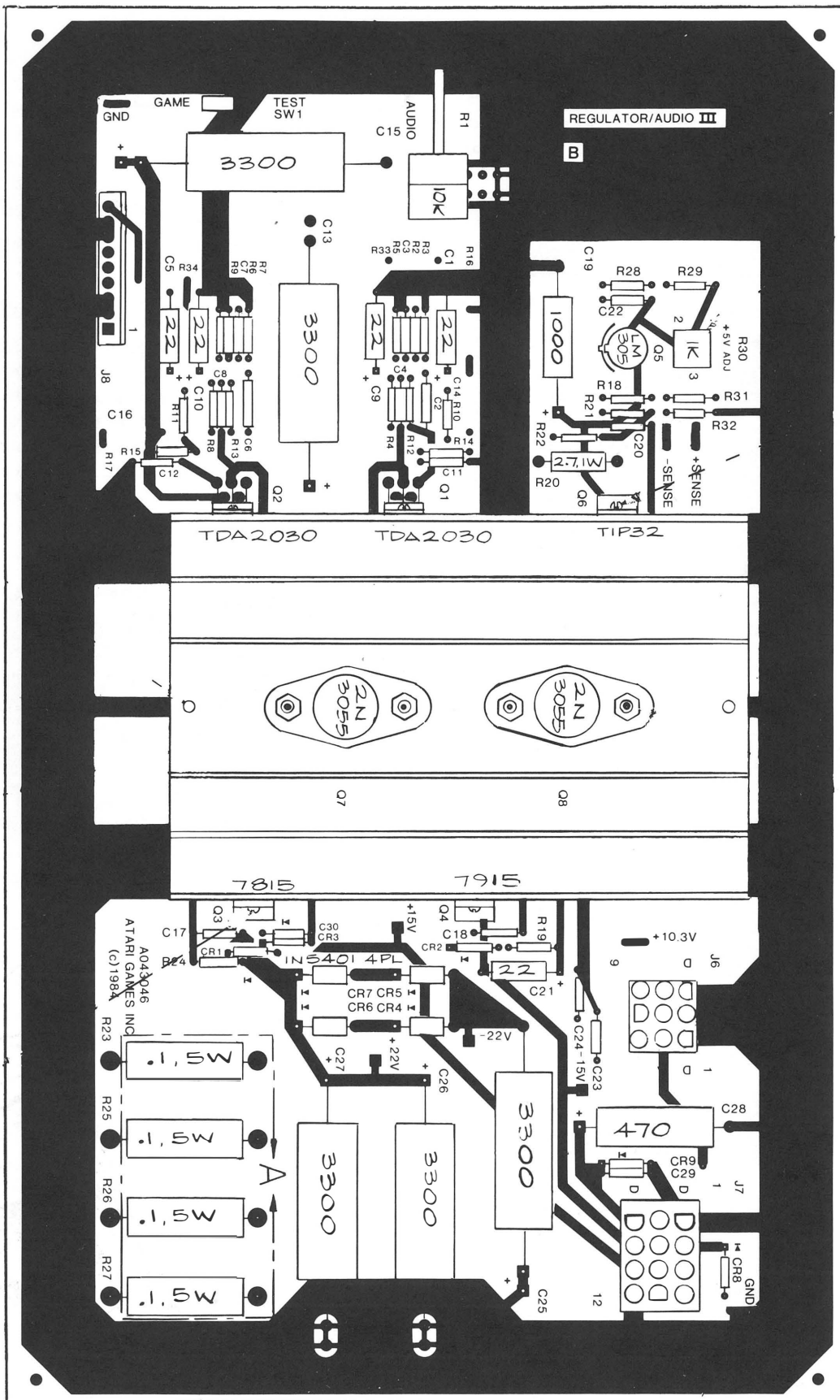

Figure 5-12 Regulator/Audio III PCB Assembly
A043046-01 B

NOTICE TO ALL PERSONS RECEIVING THIS DRAWING
 CONFIDENTIAL: Reproduction forbidden without the specific written permission of Atari Games Corporation, Sunnyvale, CA. This drawing is only conditionally issued, and neither receipt nor possession thereof confers or transfers any right in, or license to use, the subject matter of this drawing or any part thereof. Except for manufacture by vendors of Atari Games Corporation, and for manufacture under the corporation's written license, no right is granted to reproduce this drawing or the subject matter thereof, unless by written agreement with or written permission from the corporation.

Regulator/Audio III PCB Assembly Parts List

Designator	Description	Part No.
Capacitors		
C1	22 μ F, 35 V Electrolytic Capacitor	24-350226
C2	0.22 μ F, 25 V Ceramic Capacitor	122004-224
C3	0.001 μ F, 50V Ceramic Capacitor	122002-102
C4	0.1 μ F, 50V Ceramic Capacitor	122002-104
C5	22 μ F, 35 V Electrolytic Capacitor	24-350226
C6	0.22 μ F, 25 V Ceramic Capacitor	122004-224
C7	0.001 μ F, 50V Ceramic Capacitor	122002-102
C8	0.1 μ F, 50V Ceramic Capacitor	122002-104
C9	22 μ F, 35 V Electrolytic Capacitor	24-350226
C10	22 μ F, 35 V Electrolytic Capacitor	24-350226
C11, C12	0.1 μ F, 50V Ceramic Capacitor	122002-104
C13	3300 μ F, 35 V Electrolytic Capacitor	24-350338
C14	0.22 μ F, 25 V Ceramic Capacitor	122004-224
C15	3300 μ F, 35 V Electrolytic Capacitor	24-350338
C16	0.22 μ F, 25 V Ceramic Capacitor	122004-224
C17, C18	0.1 μ F, 50V Ceramic Capacitor	122002-104
C19	1000 μ F, 25 V Electrolytic Capacitor	24-250108
C20	0.1 μ F, 50V Ceramic Capacitor	122002-104
C21	22 μ F, 35 V Electrolytic Capacitor	24-350226
C22	0.001 μ F, 50V Ceramic Capacitor	122002-102
C23, C24	0.1 μ F, 50V Ceramic Capacitor	122002-104
C25-C27	3300 μ F, 35 V Electrolytic Capacitor	24-350338
C28	470 μ F, 25 V Electrolytic Capacitor	24-250477
C29	0.1 μ F, 50V Ceramic Capacitor	122002-104
Connectors		
J6	9-Circuit Header Connector	179069-009
J7	12-Circuit Header Connector	179069-012
J8	9-Circuit 0.156 Header Connector	179213-009
Diodes		
CR1-CR3	Type-1N4002 Diode	31-1N4002
CR4-CR7	1N5401 Rectifier	31-1N5401
CR8, CR9	Type-1N4002 Diode	31-1N4002
Resistors		
R2	22 k Ω , \pm 5%, $\frac{3}{4}$ W Resistor	110000-223
R3	12 k Ω , \pm 5%, $\frac{3}{4}$ W Resistor	110000-123
R4, R5	100 k Ω , \pm 5%, $\frac{3}{4}$ W Resistor	110000-104
R6	22 k Ω , \pm 5%, $\frac{3}{4}$ W Resistor	110000-223
R7	12 k Ω , \pm 5%, $\frac{3}{4}$ W Resistor	110000-123
R8, R9	100 k Ω , \pm 5%, $\frac{3}{4}$ W Resistor	110000-104
R10, R11	1 k Ω , \pm 5%, $\frac{3}{4}$ W Resistor	110000-102
R12, R13	100 k Ω , \pm 5%, $\frac{3}{4}$ W Resistor	110000-104
R14, R15	10 k Ω , \pm 5%, $\frac{3}{4}$ W Resistor	110000-103
R16, R17	1 Ω , \pm 5%, $\frac{3}{4}$ W Resistor	110000-010
R18	100 Ω , \pm 5%, $\frac{3}{4}$ W Resistor	110000-101
R19	5.6 k Ω , \pm 5%, $\frac{3}{4}$ W Resistor	110000-562
R20	2.7 Ω , \pm 5%, 1 W Resistor	110009-027
R21	27 Ω , \pm 5%, $\frac{3}{4}$ W Resistor	110000-270
R22	100 Ω , \pm 5%, $\frac{3}{4}$ W Resistor	110000-101
R23	0.1 Ω , \pm 5%, 5 W Resistor	116007-001

Regulator/Audio III PCB Assembly, continued Parts List

Designator	Description	Part No.
R24	5.6 k Ω , \pm 5%, $\frac{3}{4}$ W Resistor	110000-562
R25-R27	0.1 Ω , \pm 5%, 5 W Resistor	116007-001
R28	2.7 Ω , \pm 5%, $\frac{3}{4}$ W Resistor	110000-027
R29	7.5 k Ω , \pm 5%, $\frac{3}{4}$ W Resistor	110000-752
R31	3.9 k Ω , \pm 5%, $\frac{3}{4}$ W Resistor	110000-392
R32	2.7 Ω , \pm 5%, $\frac{3}{4}$ W Resistor	110000-027
Transistors		
Q6	T1P-32 Transistor	33-T1P32
Q7, Q8	2N3055 Transistor	34-2N3055
Miscellaneous		
Q1, Q2	TDA-2030 Amplifier	137301-001
Q3	Type-7815, +15 V Regulator	37-7815
Q4	Type-7915, -15 V Regulator	37-7915
Q5	Type-LM305 Regulator	37-LM305
R30	1k Horizontal Potentiometer	119002-102
	Heat Sink	034531-01
	Test Point (Acceptable substitute is part no. 020670-01)	179051-002



Installation

Your Atari Games System II cabinet is designed to accept the necessary kit parts to easily change to a different game. This appendix contains information that applies to those parts of your existing System II game that are added or replaced to change to the PAPERBOY game (see Figure A-1).

This appendix includes the instructions necessary for installing the PAPERBOY kit in your System II cabinet. The instructions include: (1) removing the existing attraction film, control panel, and game read-only memory (ROM); and (2) installing the PAPERBOY attraction film, game ROMs, and control panel. Refer to Figure A-1 for the locations of the parts of the System II cabinet that are replaced. The instructions are organized to install the PAPERBOY kit in the most efficient manner.



Appendix

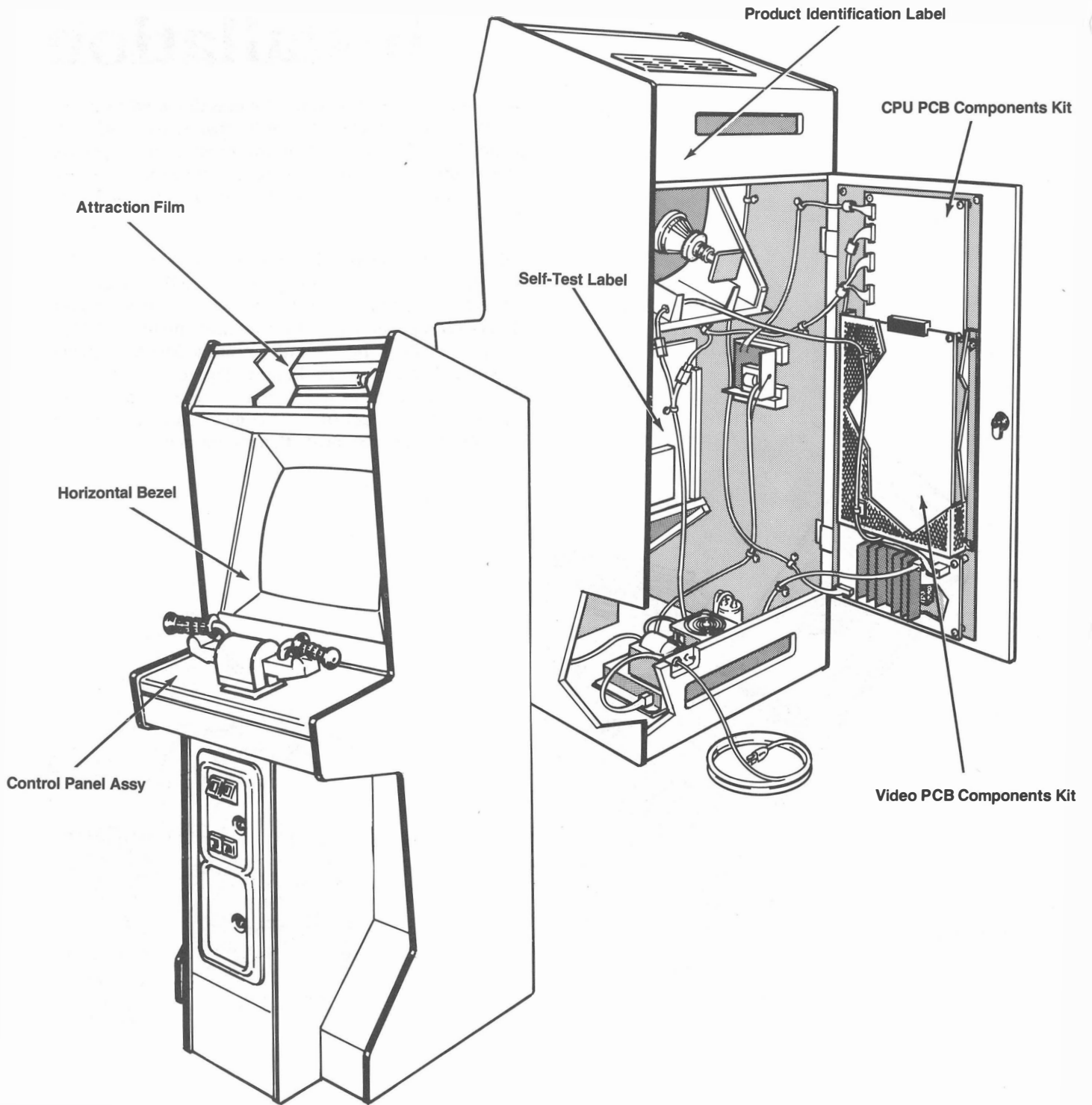

Figure A-1 Kit Part Locations

Kit Parts Inventory

The assemblies listed in Table A-1 are included in the PAPERBOY kit. Refer to Chapter 5, Illustrated Parts List, for a description of the component parts comprising the control panel assembly and game printed-circuit board (PCB) components kits.

Table A-1 Kit Parts Inventory

Part No.	Quantity	Description
A042705-01	1	Instruction Bag Kit Assembly
A043002-01	1	Control-Panel Assembly
A043005-01	1	Video PCB Components Kit
A043006-01	1	CPU PCB Components Kit
037334-01	1	Field Service Card
038158-01	1	Product Identification Label (Non-UL)
043013-01	1	Attraction Film With Graphics
043016-01	1	Horizontal Bezel
SP-275	1	Schematic Package Supplement
ST-275	1	Self-Test Label
TM-275	1	Operators Manual

Tools Required

The only tools required to install the PAPERBOY kit are a Phillips screwdriver, 1/8-inch hex driver, and integrated-circuit (IC) removing tool. (A 3/8-inch wrench is also required if your game has a vertically mounted video display.)

Installation Instructions

WARNING

To avoid electrical shock, unplug the game before performing the kit installation procedures.

NOTE

The following kit installation should be performed by qualified service personnel.

The following procedures are arranged in the sequence recommended for removing the existing parts and then installing the PAPERBOY kit parts.

Replace the Attraction Film

Perform the following procedure to remove the existing attraction film and replace it with the PAPERBOY attraction film (see Figure A-2).

1. Turn off the game power.
2. Use a 1/8-inch hex driver to remove the three screws and washers securing the upper retainer to the top of the cabinet.
3. Grasp the top edge of the existing attraction film behind the attraction shield and slide it up to remove.
4. Install the PAPERBOY attraction film behind the attraction shield. Make sure the film is fully inserted into the bottom slot.
5. Replace the upper retainer.

Replace the Control Panel

Perform the following procedure to remove the existing control panel and replace with the PAPERBOY control panel (see Figure A-3).

1. Use a 1/8-inch hex driver to loosen the two screws securing the lower retainer to the cabinet.
2. Unlock and open the coin door on the front of the cabinet.
3. Carefully reach up through the coin door opening and release the spring-draw latches located under the control panel on both sides of the cabinet.
4. Use a 1/8-inch hex driver to remove the two screws and washers securing the front of the control panel to the cabinet.
5. Gently lift the front of the control panel until the front edge clears the cabinet.
6. Carefully slide the top edge of the control panel from under the lower retainer.
7. Lift the control panel from the cabinet just far enough to expose the control-panel harness connector.
8. Disconnect the player control harness connector and remove the control panel from the cabinet.

NOTE

Check to see if your existing System II game has a vertically mounted video display. If so, do not install the PAPERBOY control panel at this time. Instead, proceed to the following procedure for horizontally mounting the video display. If your existing System II game already has a horizontally mounted video display, ignore the following procedure and proceed to the procedure for replacing the game ROMs.

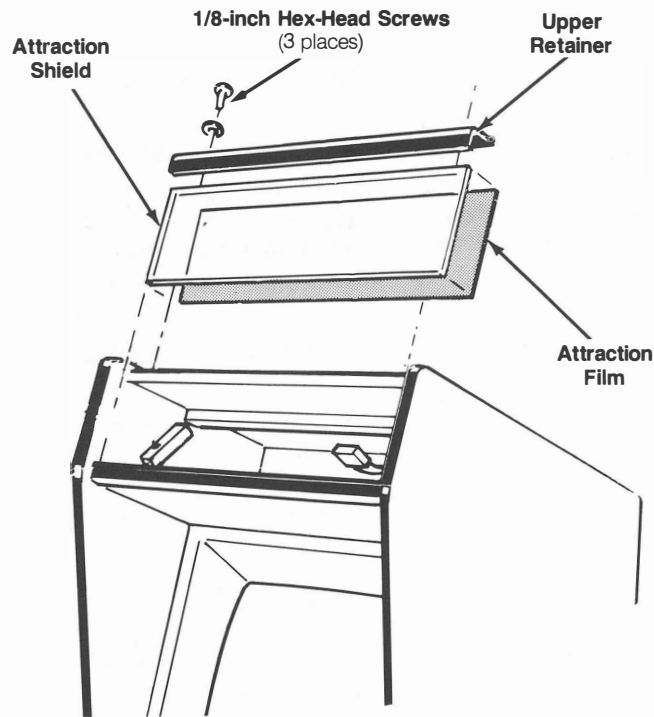

Figure A-2 Attraction Film Replacement

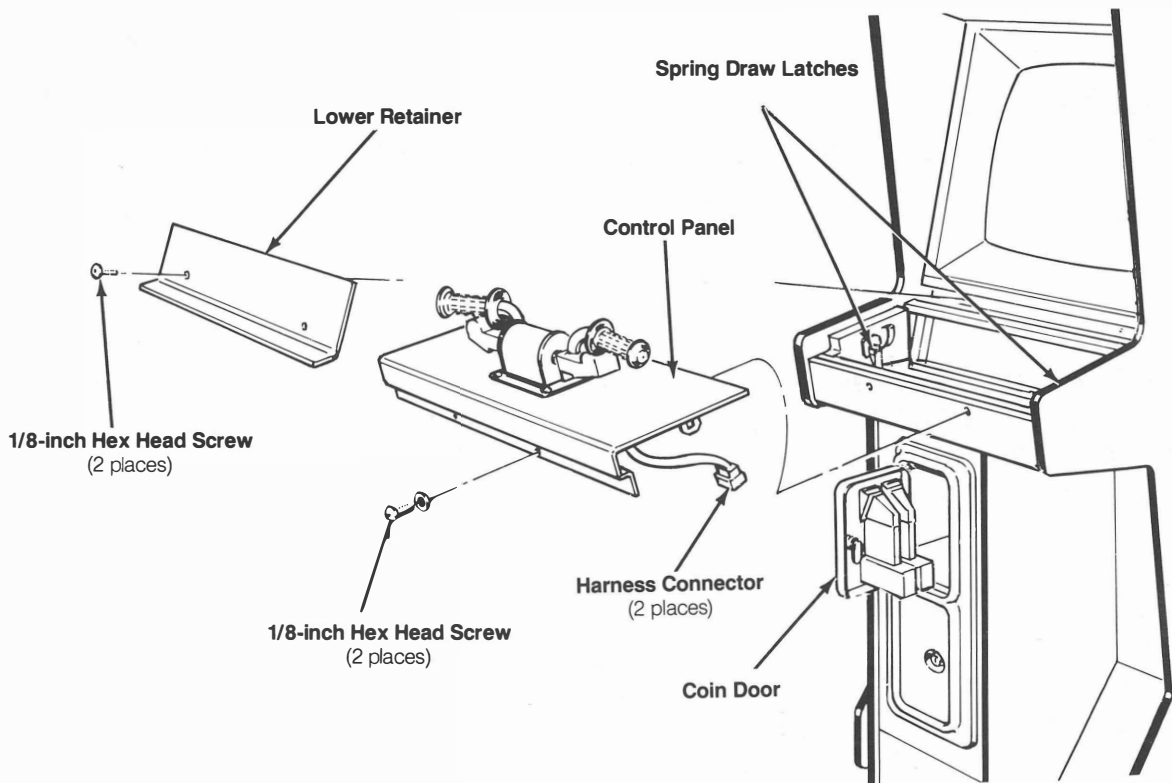

Figure A-3 Control Panel Replacement

9. Install the PAPERBOY control panel in the reverse order of removal.

Removing the Video Display

Perform the following procedure to remove the vertically mounted video display and reinstall horizontally (see Figure A-4).

1. Use a 1/8-inch hex driver to remove the two screws securing the lower retainer to the cabinet.
2. Grasp the display shield on the bottom edge and gently pull it out about a half-inch from the cabinet.
3. Gently lower the display shield to free the top edge from under the speaker grille.
4. Use a flat-head screwdriver to remove the staples, if any, securing the bezel to the cabinet.
5. Remove the bezel.

6. Unlock and open the rear access door.
7. If not done previously, turn off the game power.
8. Discharge the high-voltage from the cathode-ray tube (CRT) before proceeding. The display assembly contains a circuit for discharging the high voltage to ground when power is removed. However, to make certain, always discharge the display as follows.
 - a. Attach one end of a large, well-insulated, 18-gauge jumper wire to ground.
 - b. Momentarily touch the free end of the grounded jumper to the CRT anode by sliding it under the anode cap.
 - c. Wait two minutes and repeat part b.

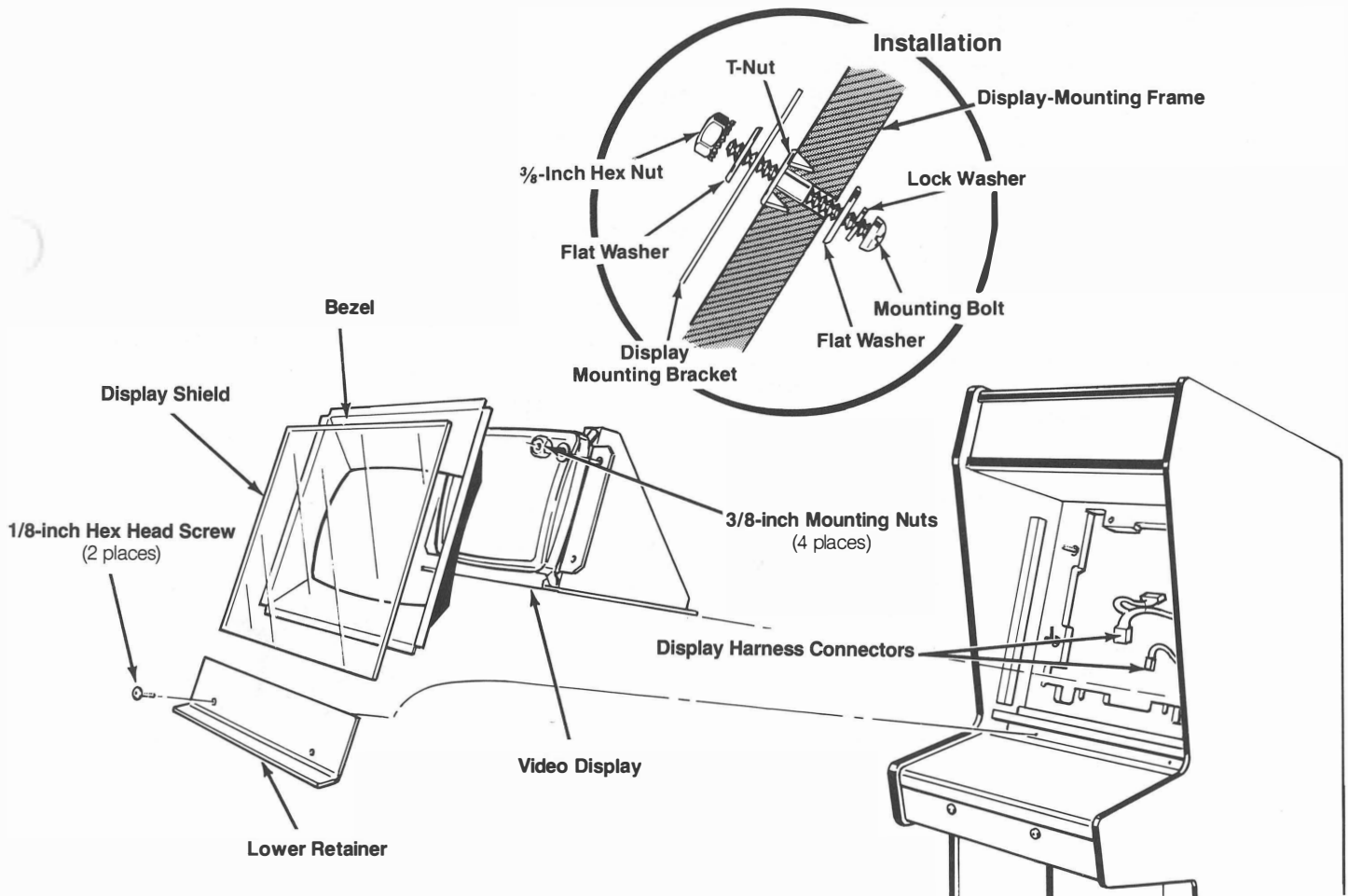

Figure A-4 Video Display Removal and Replacement

WARNING

High Voltage

This display contains lethal high voltages. To avoid injury, do not attempt to remove this display until you observe all precautions necessary for working on high-voltage equipment.

Implosion Hazard

The cathode-ray tube may implode if struck or dropped. Shattered glass may cause injury within a 6-foot radius. Use care when handling the display.

9. From the back of the cabinet, unplug the display-harness connectors and disconnect the ground wire.

WARNING

To avoid dropping the display assembly out of the game cabinet, use extreme care when removing the display-mounting nuts. We recommend that a second person *carefully* hold the display chassis from the back of the cabinet while the mounting nuts are being removed.

10. From the front of the cabinet, use a 3/8-inch wrench to remove the four nuts and flat washers securing the display to the cabinet.
11. Carefully slide the display out through the front of the cabinet.
12. Rotate the display a quarter-turn counterclockwise and replace in the cabinet with the horizontal mounting bolts inserted through the proper holes in the display mounting brackets.
13. Install the two nuts and washers to secure the video display to the cabinet.
14. Replace the existing vertical bezel with the PAPERBOY horizontal bezel and reinstall the display shield in the reverse order of removal.
15. Install the PAPERBOY control panel in the reverse order of the previous control panel removal procedure.

Replace the Game ROMs

Perform the following procedure to remove the existing game ROMs and install the PAPERBOY game ROMs (see Figure A-5).

1. Turn the cabinet power off.

2. Unlock and open the rear access door.
3. Use your fingers to remove the four wing nuts securing the EMI shield to the ground plane.
4. Use an integrated-circuit (IC) removing tool to carefully remove the game ROMs shown in Figure A-5.
5. Carefully install the part numbered PAPERBOY game ROMs in the appropriate sockets on the CPU and Video PCBs as shown in Figure A-5. Slide a block of wood or similar device behind the PCBs to prevent the PCBs from bending excessively as the ROMs are being installed. Make sure that the game ROMs are properly oriented and firmly seated in their sockets.

NOTE

Some of the integrated-circuit sockets may be left empty since the System II game PCBs are designed to accommodate different ROMs for a variety of games.

Install the Self-Test Label

Staple or tape the PAPERBOY self-test label on the inside of the rear access door.

Install the Labels

Perform the following procedure to install the PAPERBOY product identification label.

1. Remove the protective backing from the PAPERBOY product identification label.
2. Place the PAPERBOY product identification label over the existing product identification label on the back of the cabinet.

Inspect the Game

Before applying power, perform the following inspection procedure.

1. Carefully check that the PAPERBOY kit parts have been properly installed. Make sure the control-panel harness connector is tightly connected and that the spring-draw latches under the control panel are securely fastened.
2. When you are confident that all instructions were properly followed, plug in the game power cord and turn on the power.
3. Perform the self-test procedure as described in Chapter 2 of this manual. If the self-test indicates that the display requires adjustment, perform the adjustment procedures described in the display manual.
4. Close and lock the rear access door.

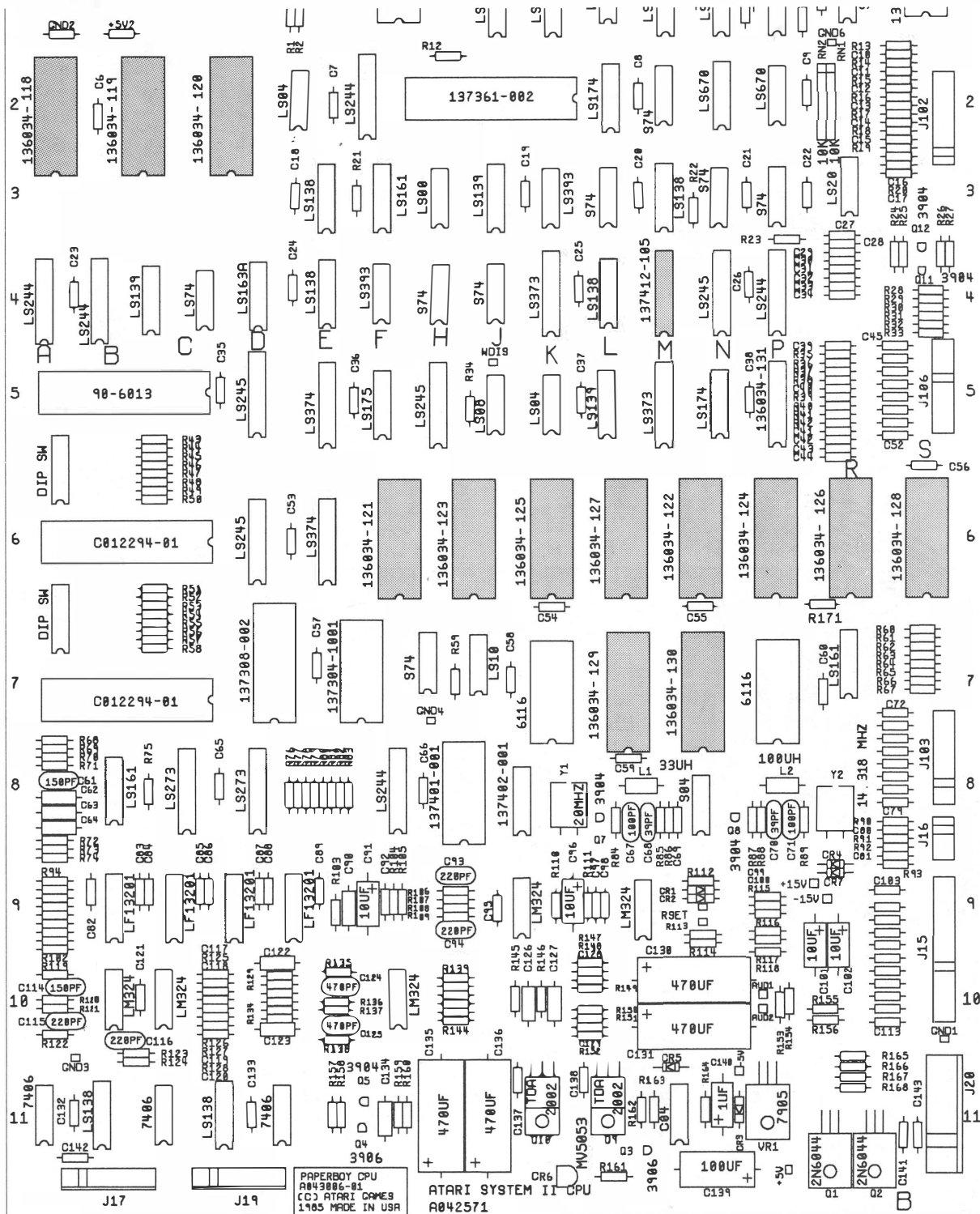

NOTICE TO ALL PERSONS RECEIVING THIS DRAWING
CONFIDENTIAL: Reproduction forbidden without the specific written permission of Atari Games Corporation, Sunnyvale, CA. This drawing is only conditionally issued, and neither receipt nor possession thereof confers any right in, or license to use, the subject matter of the drawing or any design or technical information shown thereon, nor any right to reproduce this drawing or any part thereof. Except for manufacture by vendors of Atari Games Corporation, and for manufacture under the corporation's written license, no right is granted to reproduce this drawing or the subject matter thereof, unless by written agreement with or written permission from the corporation.

Figure A-5 Game ROM Replacement

NOTICE TO ALL PERSONS RECEIVING THIS DRAWING
 CONFIDENTIAL - Reproduction forbidden without the specific written permission of Atari Games Corporation, Sunnyvale, CA. This drawing is only conditionally issued, and neither receipt nor possession thereof confers or transfers any right in, or license to use, the subject matter of the drawing or any design or technical information shown thereon, nor any right to reproduce this drawing or any part thereof. Except for manufacture by vendors of Atari Games Corporation, and for manufacture under the corporation's written license, no right is granted to reproduce this drawing or the subject matter thereof, unless by written agreement with or written permission from the corporation.

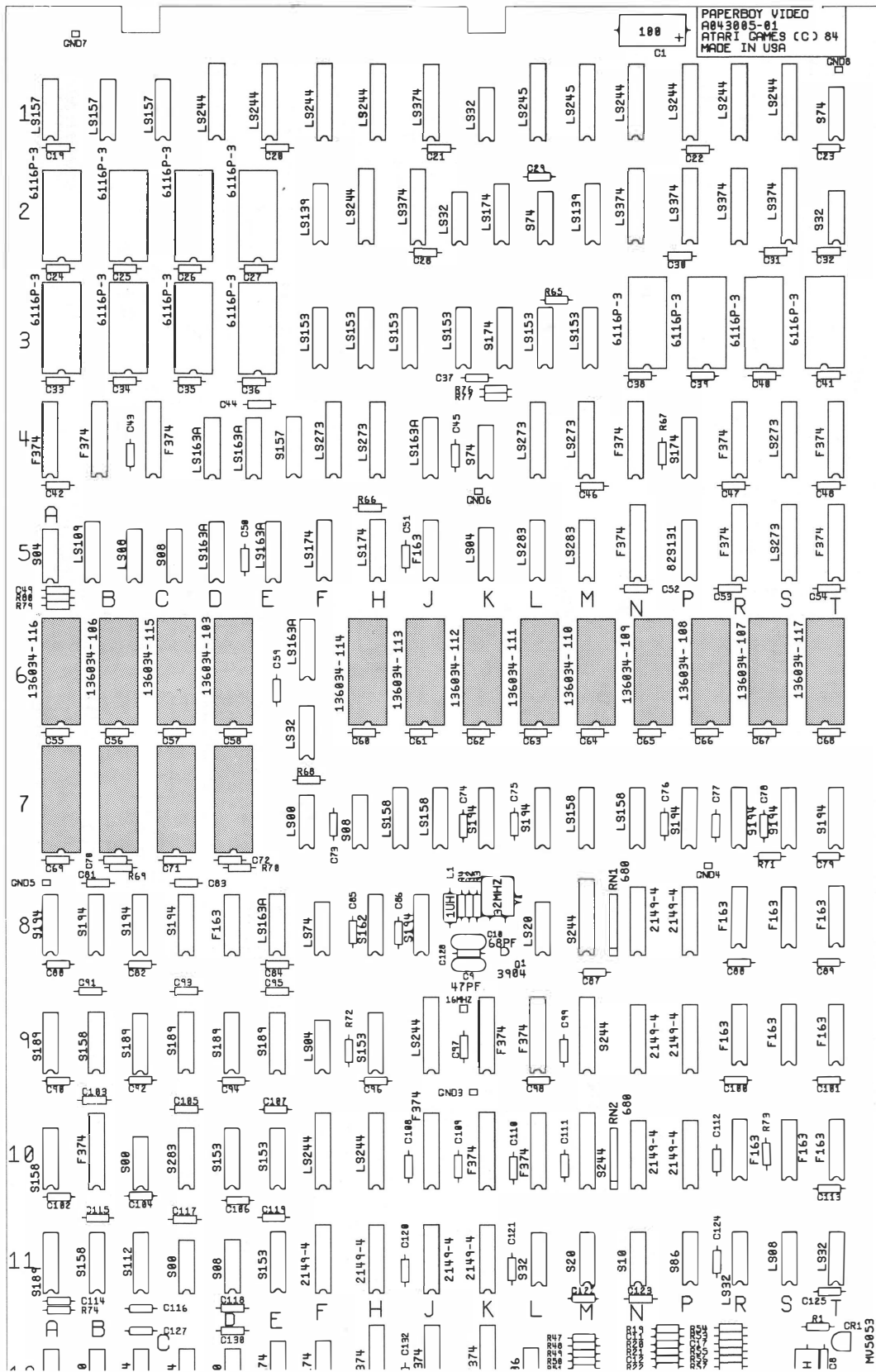

Figure A-5 Game ROM Replacement, continued

Setting the Coin and Game Options

The PAPERBOY coin and game options are set by dual in-

line package (DIP) switches located on the CPU PCB. Refer to Chapter 1 for the recommended settings and the procedure for setting the options.



N O T E S

YOUR COMMENTS, PLEASE!

Your comments will assist Atari Games Corporation in improving our publications. The comments are an important part of preparing for revisions of game manuals. Please write in the space below. No postage stamp is necessary if mailed in the U.S.A.

If you have any technical questions about certain ATARI games products, or are requesting additional technical publications, we will immediately forward your note to the appropriate person.

Page: Comments:

Fill in if you wish a reply:

Name _____

Firm _____

Address _____

City _____ Country _____

Phone: Country Code _____ Local Number _____

Distributor

Operator

Other _____

Tape This Edge

First Fold

No postage
necessary if
mailed in the
United States

BUSINESS REPLY MAIL

FIRST CLASS PERMIT NO. 173 MILPITAS, CA

POSTAGE WILL BE PAID BY ADDRESSEE

Atari Games Corporation
Attn: Customer Service
737 Sycamore Drive
P.O. Box 906
Milpitas, California 95035

Second Fold

From: _____

YOUR COMMENTS, PLEASE!

Your comments will assist Atari Games Corporation in improving our publications. The comments are an important part of preparing for revisions of game manuals. Please write in the space below. No postage stamp is necessary if mailed in the U.S.A.

If you have any technical questions about certain ATARI games products, or are requesting additional technical publications, we will immediately forward your note to the appropriate person.

Page: Comments:

Fill in if you wish a reply:

Name _____

Firm _____

Address _____

City _____ State _____ Zip _____

Area Code _____ Phone _____

Distributor

Operator

Other _____

Tape This Edge

First Fold

Attach
Necessary
Postage

**Atari Games Corporation
Attn: Customer Service
Tipperary Town, Ireland**

Second Fold

From: _____

Warranty

Seller warrants that its printed-circuit boards and parts thereon are free from defects in material and workmanship under normal use and service for a period of ninety (90) days from date of shipment. Seller warrants that its video displays and LaserVideo disc players (in games supplied with displays and video-disc players) are free from defects in material and workmanship under normal use and service for a period of thirty (30) days from date of shipment. None of the Seller's other products or parts thereof are warranted.

If the products described in this manual fail to conform to this warranty, Seller's sole liability shall be, at its option, to repair, replace, or credit Buyer's account for such products which are returned to Seller during said warranty period, provided:

- (a) Seller is promptly notified in writing upon discovery by Buyer that said products are defective;
- (b) Such products are returned prepaid to Seller's plant; and
- (c) Seller's examination of said products discloses to Seller's satisfaction that such alleged defects existed and were not caused by accident, misuse, neglect, alteration, improper repair, installation, or improper testing.

In no event shall Seller be liable for loss of profits, loss of use, incidental or consequential damages.

Except for any express warranty set forth in a written contract between Seller and Buyer which contract supersedes the terms herein, this warranty is expressed in lieu of all other warranties expressed or implied, including the implied warranties of merchantability and fitness for a particular purpose, and of all other obligations or liabilities on the Seller's part, and it neither assumes nor authorizes any other person to assume for the Seller any other liabilities in connection with the sale of products by Seller.

The use of any non-Atari parts may void your warranty, according to the terms of the warranty. The use of any non-Atari parts may also adversely affect the safety of your game and cause injury to you and others. Be very cautious in using non-Atari-supplied components with our games, in order to ensure your safety.

Atari distributors are independent, being privately owned and operated. In their judgment they may sell parts or accessories other than Atari parts or accessories. Atari Games Corporation cannot be responsible for the quality, suitability or safety of any non-Atari part or any modification including labor which is performed by such distributor.

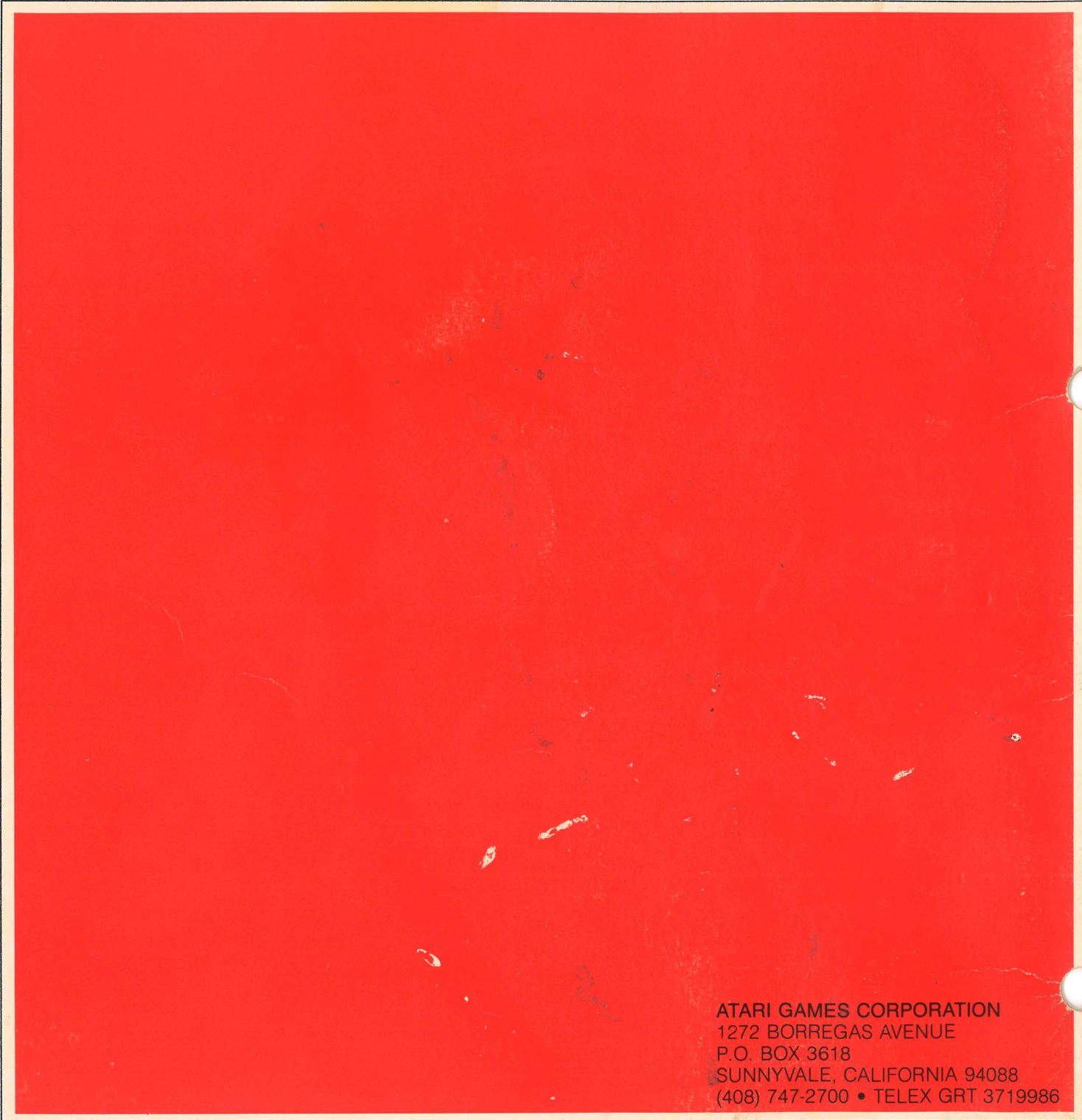

ATARI GAMES CORPORATION
1272 BORREGAS AVENUE
P.O. BOX 3618
SUNNYVALE, CALIFORNIA 94088
(408) 747-2700 • TELEX GRT 3719986