



ESCAPE

FROM THE PLANET OF THE
ROBOT MONSTERS™

Schematic Package
Supplement to the Operator's Manual

Contents

Escape From the Planet of the Robot Monsters

Main Wiring Diagram Sheet 1

Escape Main PCB Assembly Schematic Diagram Sheets 2-10

Stand-Alone Audio PCB Assembly Schematic Diagram Sheet 11-14

Power Supply and Coin Door Wiring Diagrams
and Schematic Diagram for the Hitron Power Supply Sheet 15

Memory Map, RAM and ROM Error Locations, and Hall
Effect Joystick PCB Assembly Schematic Diagram Sheet 16

NOTE

Several of the Escape Main PCB and Stand-Alone Audio PCB schematic pages have circuits continued on other sheets, using references such as "SHT 2." These sheet numbers are the numbers originally used when the schematics were drawn, and do *not* refer to the sheet numbers in the bottom right corners. Use these tables to determine circuit continuations:

Escape Main PCB

Labeled Schematic Sheet Number:	Schematic Package Sheet Number:
SHT 1	Sheet 2
SHT 2	Sheet 3
SHT 3	Sheet 4
SHT 4	Sheet 5
SHT 5	Sheet 6
SHT 6	Sheet 7
SHT 7	Sheet 8
SHT 8	Sheet 9
SHT 9	Sheet 10

Stand-Alone Audio PCB

Labeled Schematic Sheet Number:	Schematic Package Sheet Number:
SHT 1	Sheet 11
SHT 2	Sheet 12
SHT 3	Sheet 13
SHT 4	Sheet 14



Atari Games Corporation, Customer Service

737 Sycamore Drive • Milpitas, CA 95035-1110
(408) 434-3950 • Fax (408) 434-3945 • Telex 5101007850

Atari Games Ireland Limited, European Customer Service

Tipperary Town • Ireland
062-52155 • Fax 062-51702 • Telex 70665

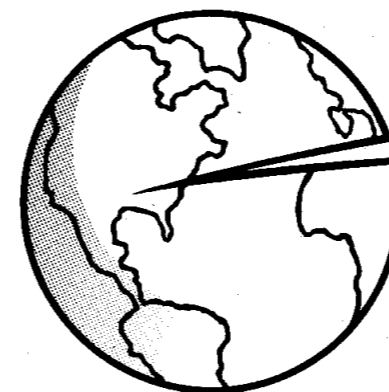

This staple temporarily holds the schematic package together. Remove the staple before using these schematics.

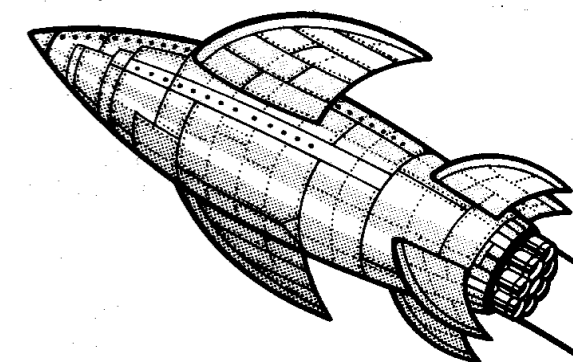

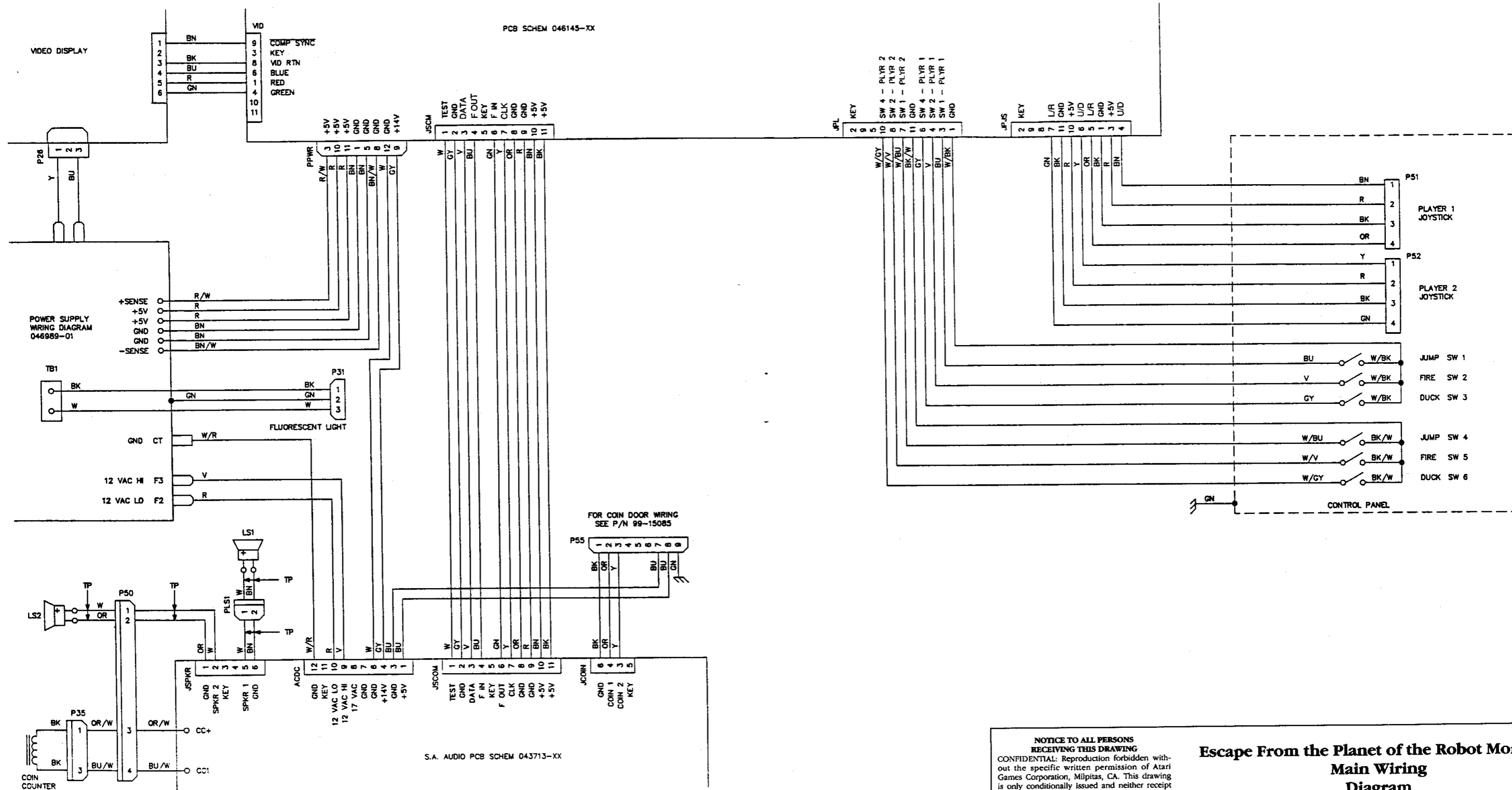

NOTICE TO ALL PERSONS RECEIVING THIS DRAWING

CONFIDENTIAL: Reproduction forbidden without the specific written permission of Atari Games Corporation, Milpitas, CA. This drawing is only conditionally issued and neither receipt nor possession thereof confers or transfers any right in, or license to use, the subject matter of the drawing or any design or technical information shown thereon, nor any right to reproduce this drawing, or any part thereof. Except for manufacture by vendors of Atari Games Corporation, and for manufacture under the corporation's written license, no right is granted to reproduce this drawing or the subject matter thereof, unless by written agreement with or written permission from the corporation.

Escape From the Planet of the Robot Monsters
Main Wiring Diagram

© 1989 Atari Games Corporation
046977-01 A

SP-332 Sheet 1
1st printing

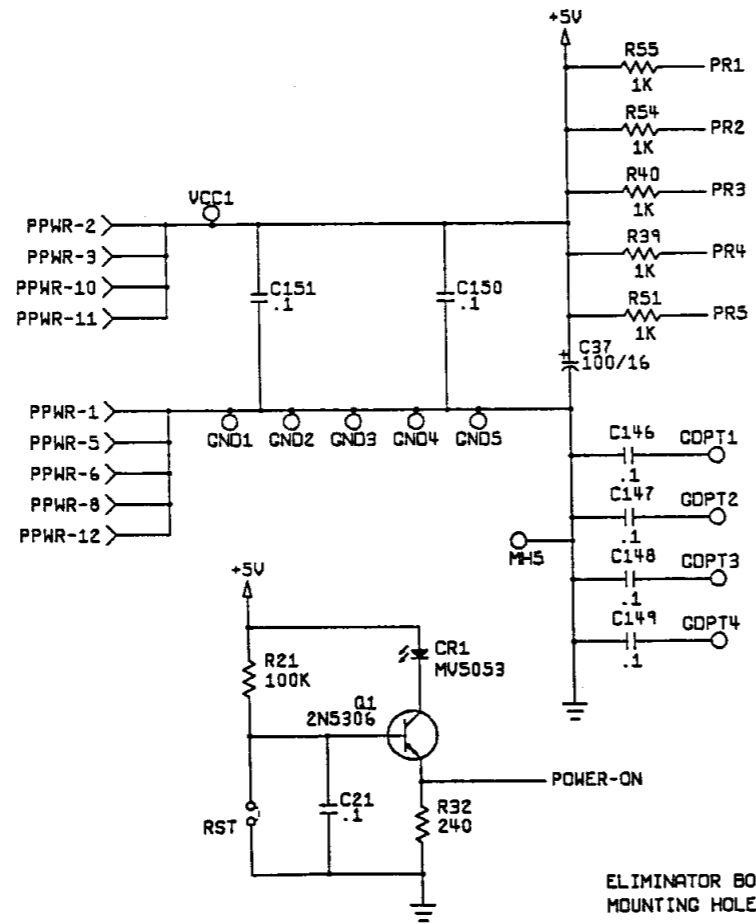
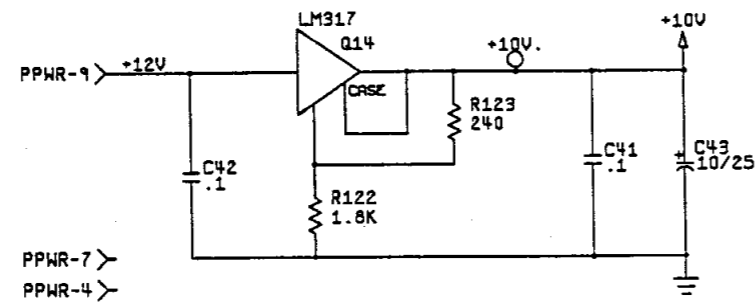
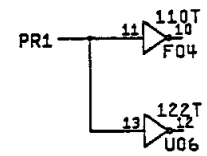
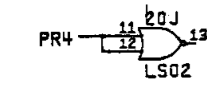
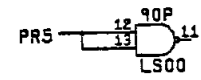

- ELIMINATOR BOARD MOUNTING HOLES
- MH1
 - MH2
 - MH3
 - MH4

SI/O

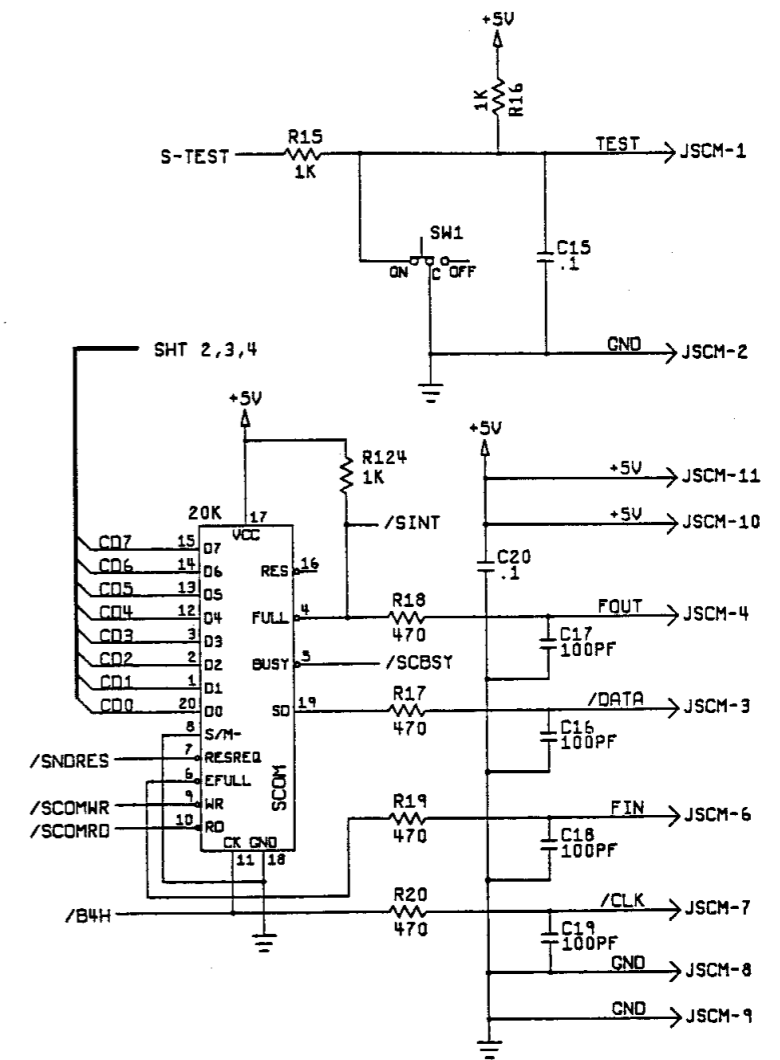

NOTICE TO ALL PERSONS RECEIVING THIS DRAWING
 CONFIDENTIAL: Reproduction forbidden without the specific written permission of Atari Games Corporation, Milpitas, CA. This drawing is only conditionally issued and neither receipt nor possession thereof confers or transfers any right in, or license to use, the subject matter of the drawing or any design or technical information shown thereon, nor any right to reproduce this drawing, or any part thereof. Except for manufacture by vendors of Atari Games Corporation, and for manufacture under the corporation's written license, no right is granted to reproduce this drawing or the subject matter thereof, unless by written agreement with or written permission from the corporation.

Escape From the Planet of the Robot Monsters
Main PCB Assembly Schematic Diagram

© 1989 Atari Games Corporation
 A046145-01 D

SP-332 Sheet 2
1st printing

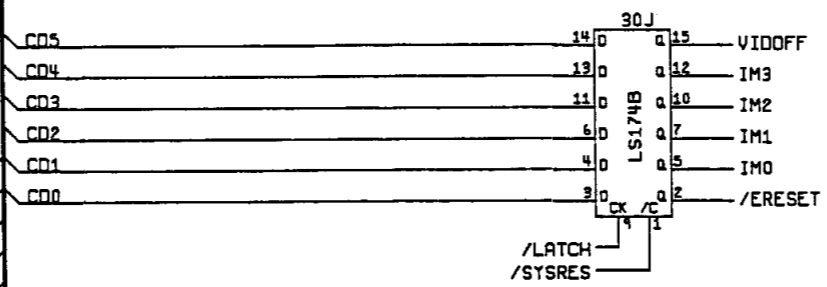
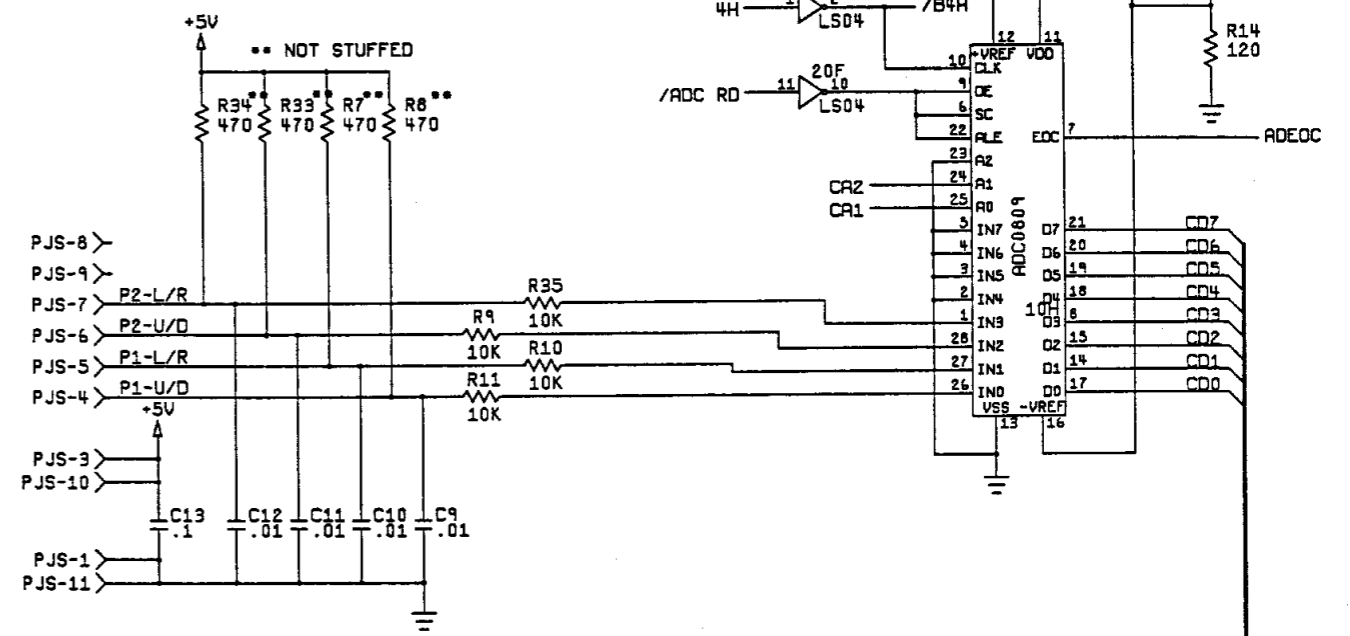
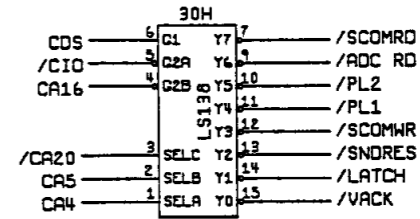
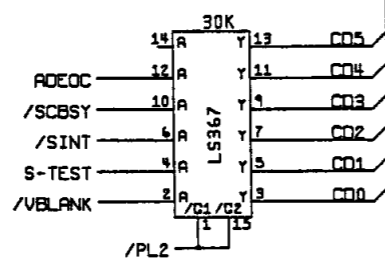
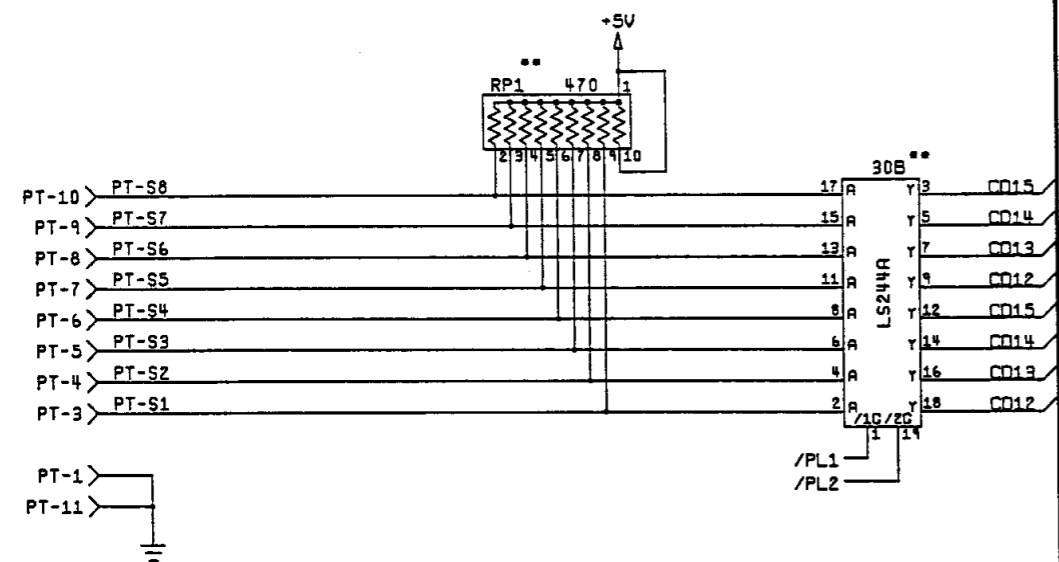
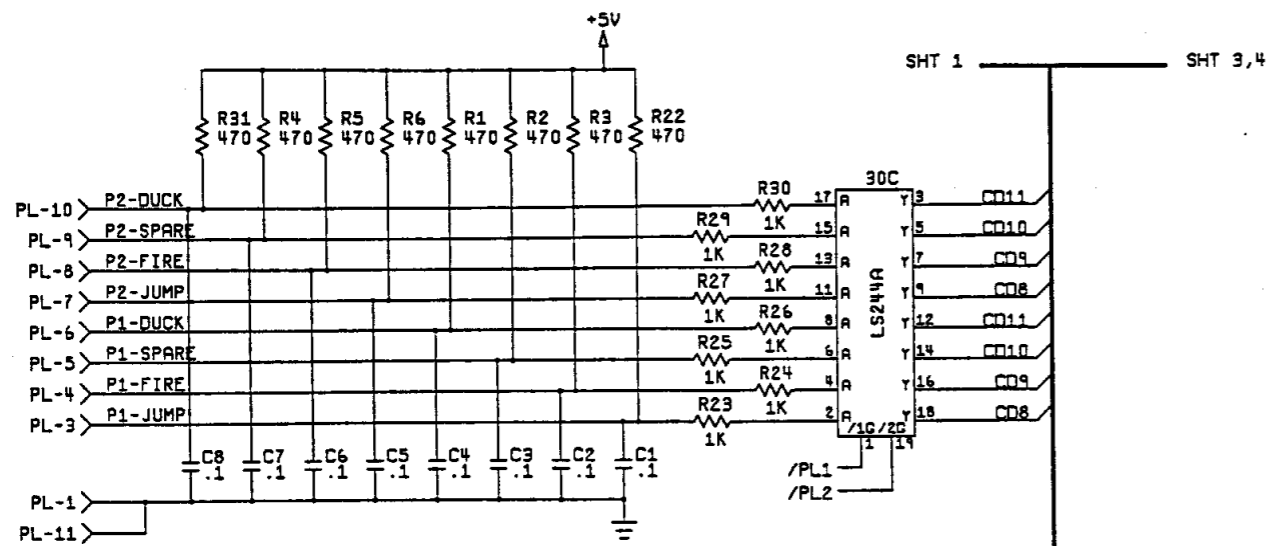

I/O

NOTICE TO ALL PERSONS RECEIVING THIS DRAWING
 CONFIDENTIAL: Reproduction forbidden without the specific written permission of Atari Games Corporation, Milpitas, CA. This drawing is only conditionally issued and neither receipt nor possession thereof confers or transfers any right in, or license to use, the subject matter of the drawing or any design or technical information shown thereon, nor any right to reproduce this drawing, or any part thereof. Except for manufacture by vendors of Atari Games Corporation, and for manufacture under the corporation's written license, no right is granted to reproduce this drawing or the subject matter thereof, unless by written agreement with or written permission from the corporation.

Escape From the Planet of the Robot Monsters
Main PCB Assembly Schematic Diagram

© 1989 Atari Games Corporation
 A046145-01 D

SP-332 Sheet 3
 1st printing

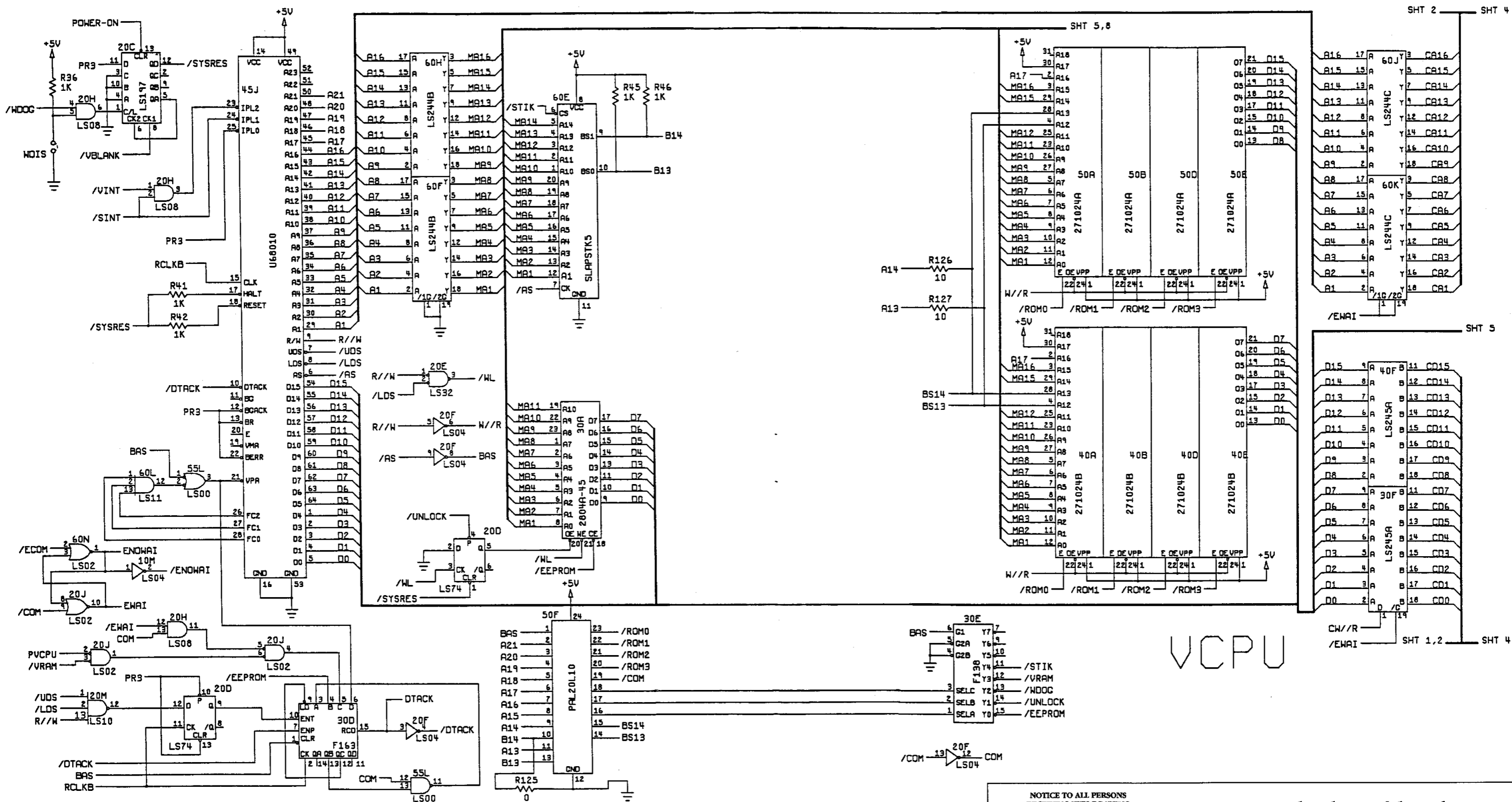

VCPU

NOTICE TO ALL PERSONS RECEIVING THIS DRAWING
 CONFIDENTIAL: Reproduction forbidden without the specific written permission of Atari Games Corporation, Milpitas, CA. This drawing is only conditionally issued and neither receipt nor possession thereof confers or transfers any right in, or license to use, the subject matter of the drawing or any design or technical information shown thereon, nor any right to reproduce this drawing, or any part thereof. Except for manufacture by vendors of Atari Games Corporation, and for manufacture under the corporation's written license, no right is granted to reproduce this drawing or the subject matter thereof, unless by written agreement with or written permission from the corporation.

**Escape From the Planet of the Robot Monsters
 Main PCB Assembly
 Schematic Diagram**

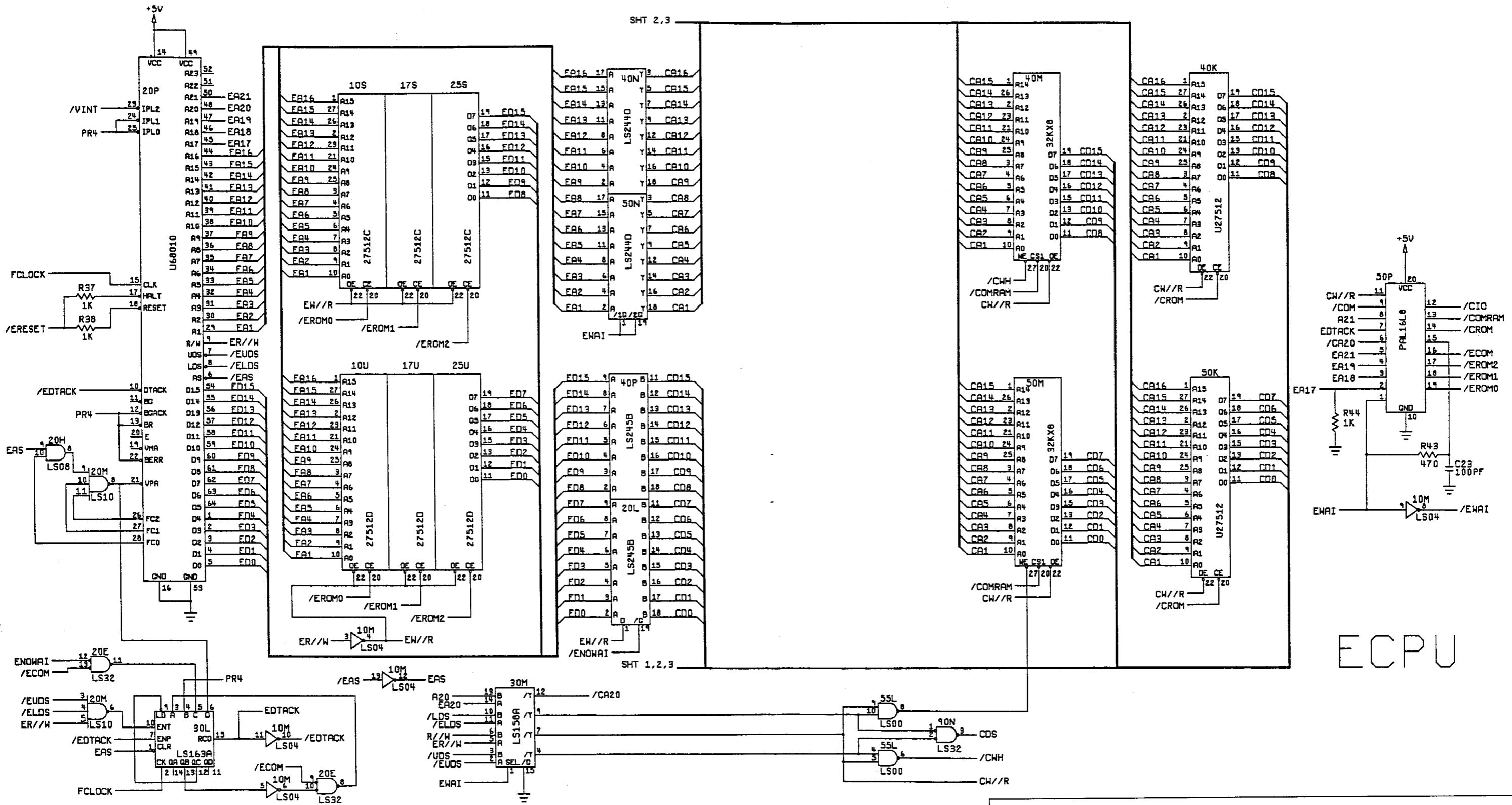

EPCPU

NOTICE TO ALL PERSONS RECEIVING THIS DRAWING
 CONFIDENTIAL: Reproduction forbidden without the specific written permission of Atari Games Corporation, Milpitas, CA. This drawing is only conditionally issued and neither receipt nor possession thereof confers or transfers any right in, or license to use, the subject matter of the drawing or any design or technical information shown thereon, nor any right to reproduce this drawing, or any part thereof. Except for manufacture by vendors of Atari Games Corporation, and for manufacture under the corporation's written license, no right is granted to reproduce this drawing or the subject matter thereof, unless by written agreement with or written permission from the corporation.

Escape From the Planet of the Robot Monsters
Main PCB Assembly
Schematic Diagram

© 1989 Atari Games Corporation
 A046145-01 D

SP-332 Sheet 5
 1st printing

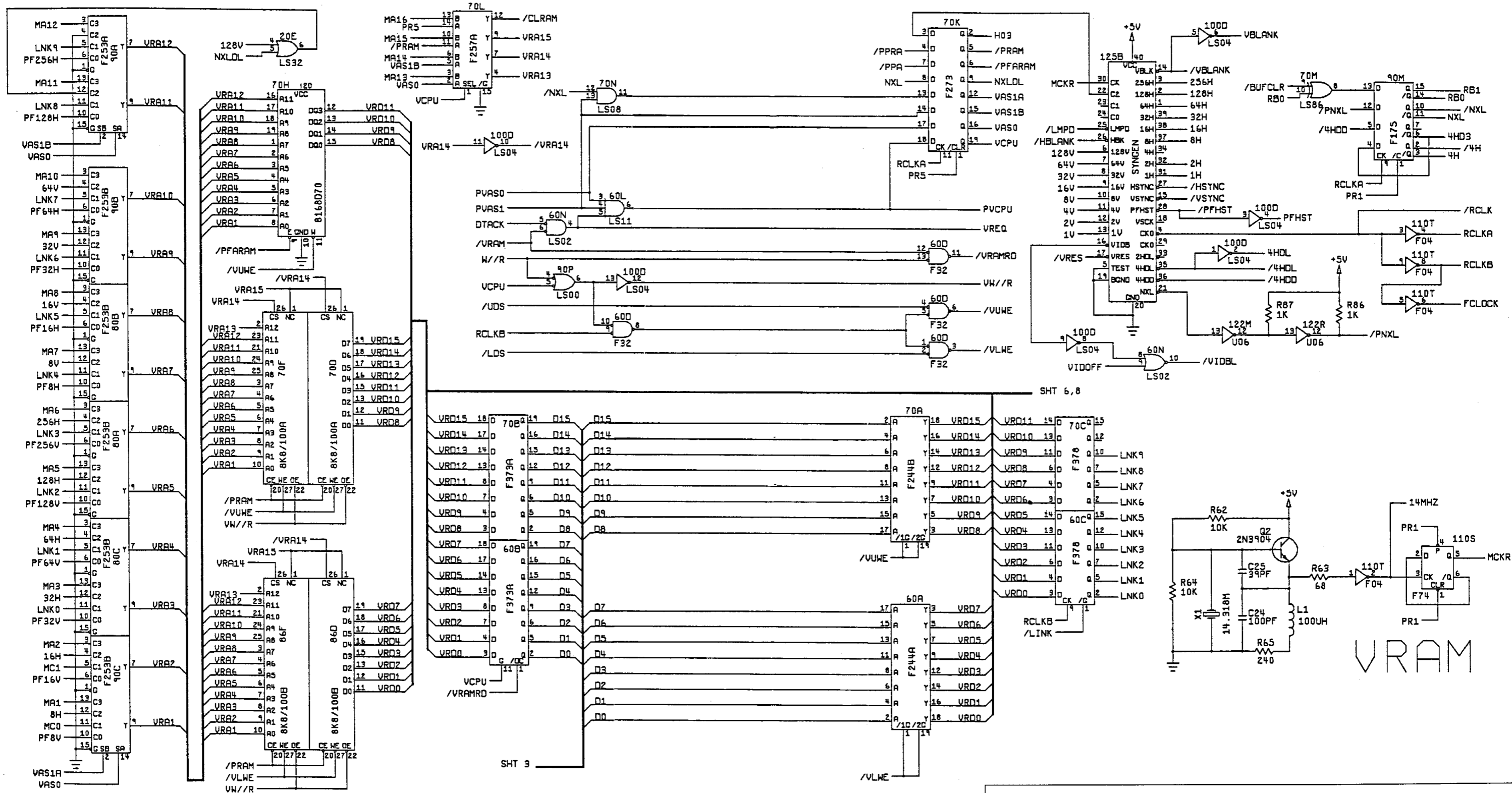

NOTICE TO ALL PERSONS RECEIVING THIS DRAWING
 CONFIDENTIAL: Reproduction forbidden without the specific written permission of Atari Games Corporation, Milpitas, CA. This drawing is only conditionally issued and neither receipt nor possession thereof confers or transfers any right in, or license to use, the subject matter of the drawing or any design or technical information shown thereon, nor any right to reproduce this drawing, or any part thereof. Except for manufacture by vendors of Atari Games Corporation, and for manufacture under the corporation's written license, no right is granted to reproduce this drawing or the subject matter thereof, unless by written agreement with or written permission from the corporation.

Escape From the Planet of the Robot Monsters
Main PCB Assembly
Schematic Diagram

© 1989 Atari Games Corporation
 A046145-01 D

SP-332 Sheet 6
 1st printing

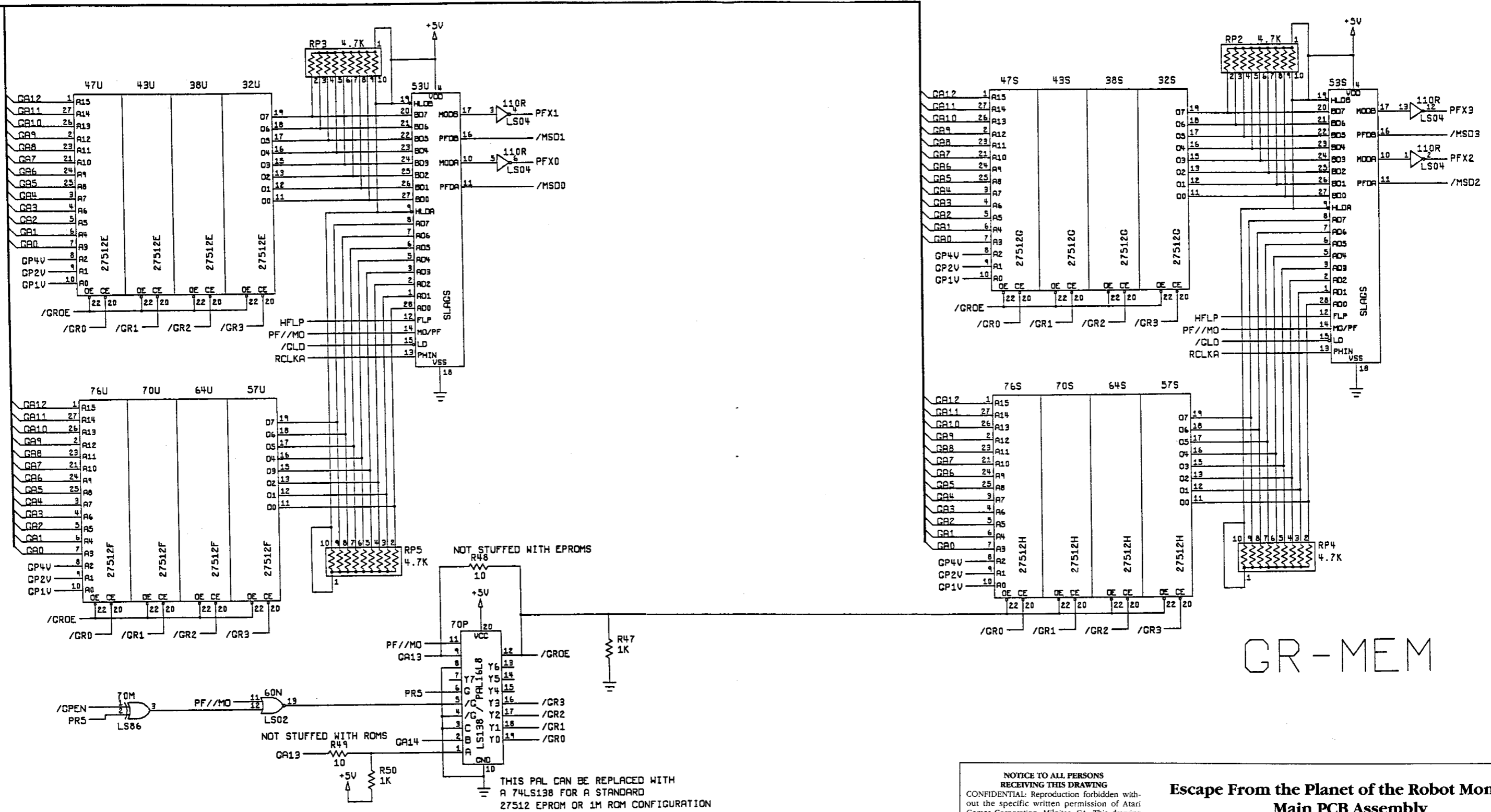

GR-MEM

NOTICE TO ALL PERSONS RECEIVING THIS DRAWING
 CONFIDENTIAL: Reproduction forbidden without the specific written permission of Atari Games Corporation, Milpitas, CA. This drawing is only conditionally issued and neither receipt nor possession thereof confers or transfers any right in, or license to use, the subject matter of the drawing or any design or technical information shown thereon, nor any right to reproduce this drawing, or any part thereof. Except for manufacture by vendors of Atari Games Corporation, and for manufacture under the corporation's written license, no right is granted to reproduce this drawing or the subject matter thereof, unless by written agreement with or written permission from the corporation.

Escape From the Planet of the Robot Monsters
Main PCB Assembly
Schematic Diagram

© 1989 Atari Games Corporation
 A046145-01 D

SP-332 Sheet 8
 1st printing

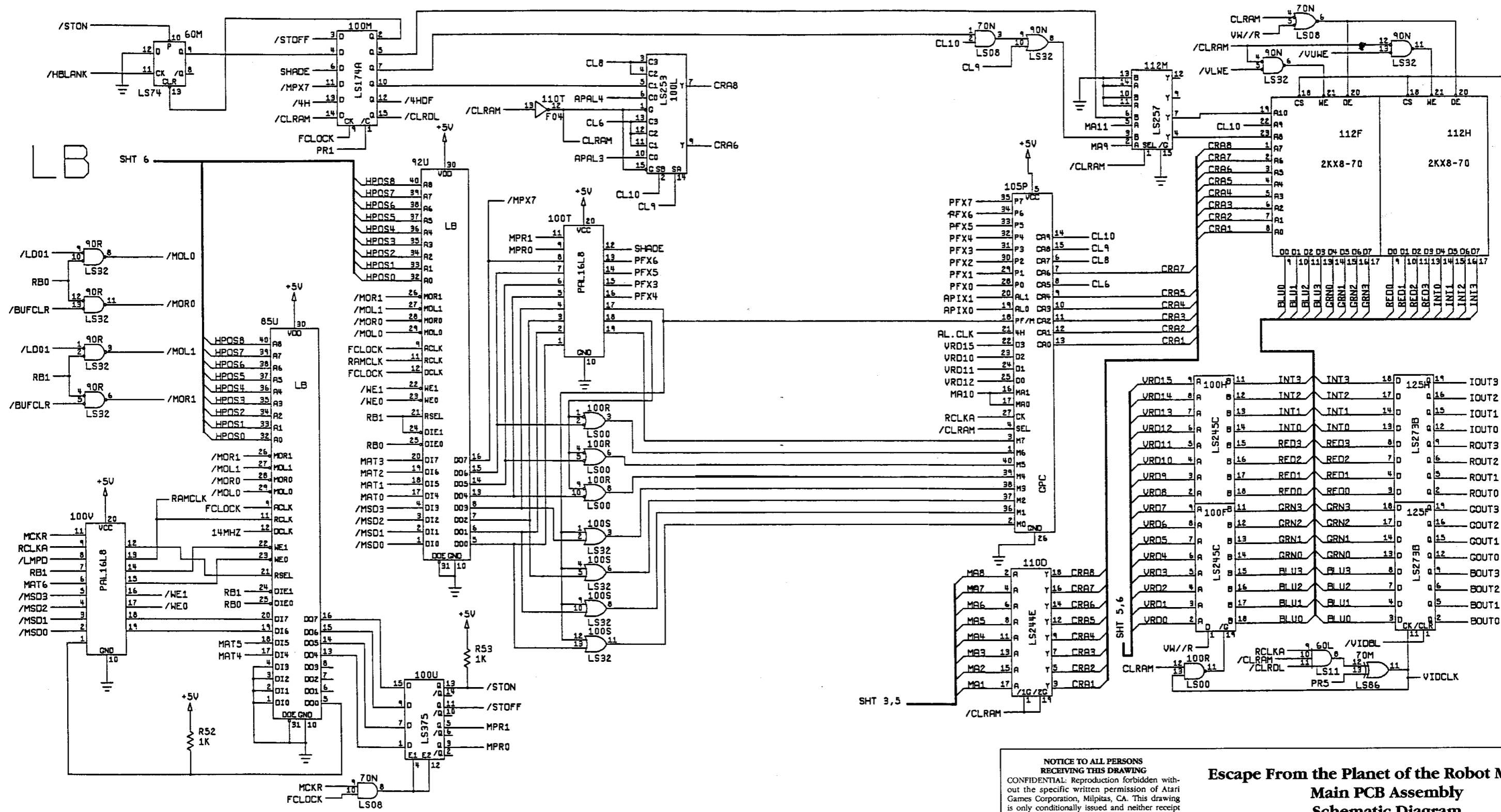

VOUT

NOTICE TO ALL PERSONS RECEIVING THIS DRAWING
 CONFIDENTIAL: Reproduction forbidden without the specific written permission of Atari Games Corporation, Milpitas, CA. This drawing is only conditionally issued and neither receipt nor possession thereof confers or transfers any right in, or license to use, the subject matter of the drawing or any design or technical information shown thereon, nor any right to reproduce this drawing, or any part thereof. Except for manufacture by vendors of Atari Games Corporation, and for manufacture under the corporation's written license, no right is granted to reproduce this drawing or the subject matter thereof, unless by written agreement with or written permission from the corporation.

Escape From the Planet of the Robot Monsters
Main PCB Assembly
Schematic Diagram

© 1989 Atari Games Corporation
 A046145-01 D

SP-332 Sheet 9
1st printing

RESISTORS MARKED ** MAY NOT BE INSTALLED.

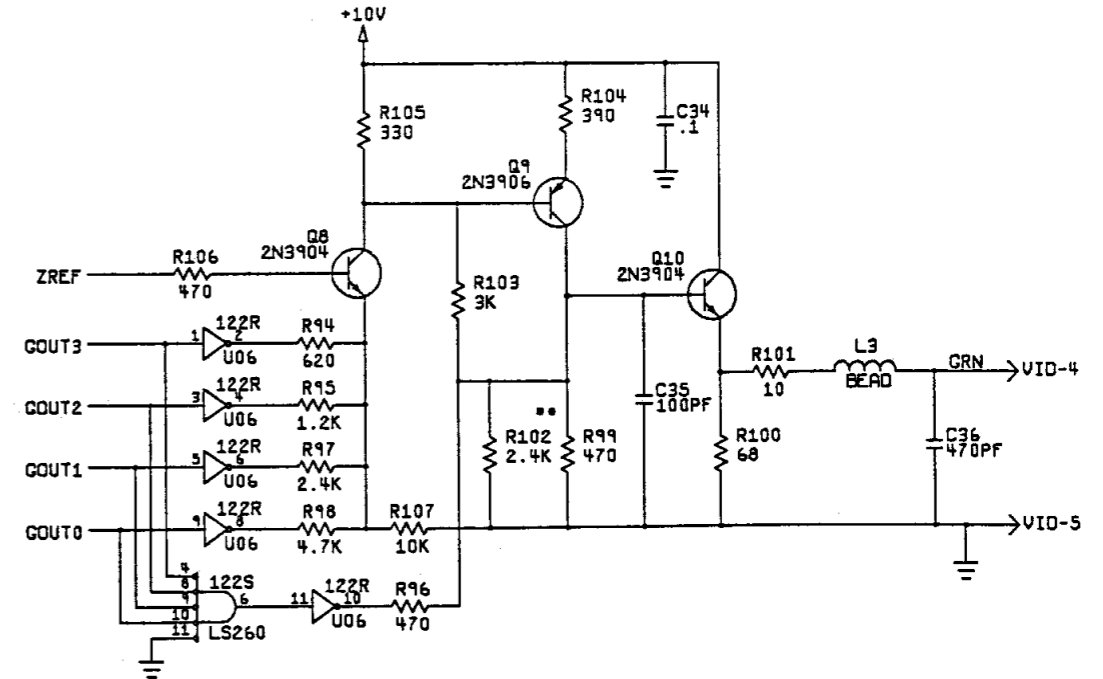
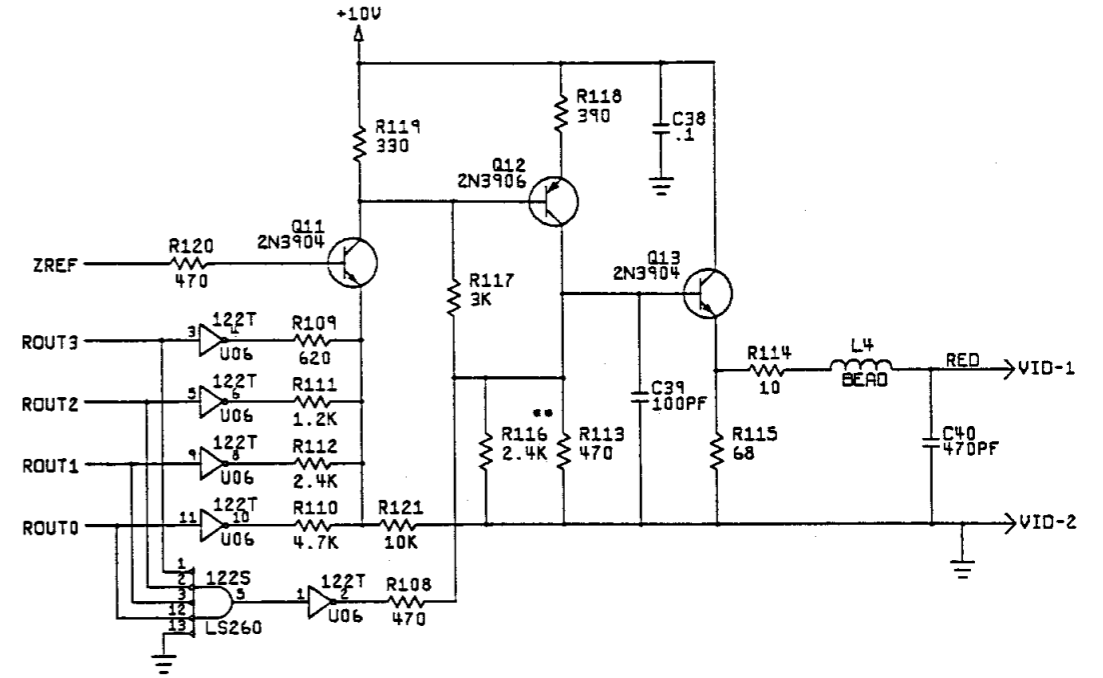
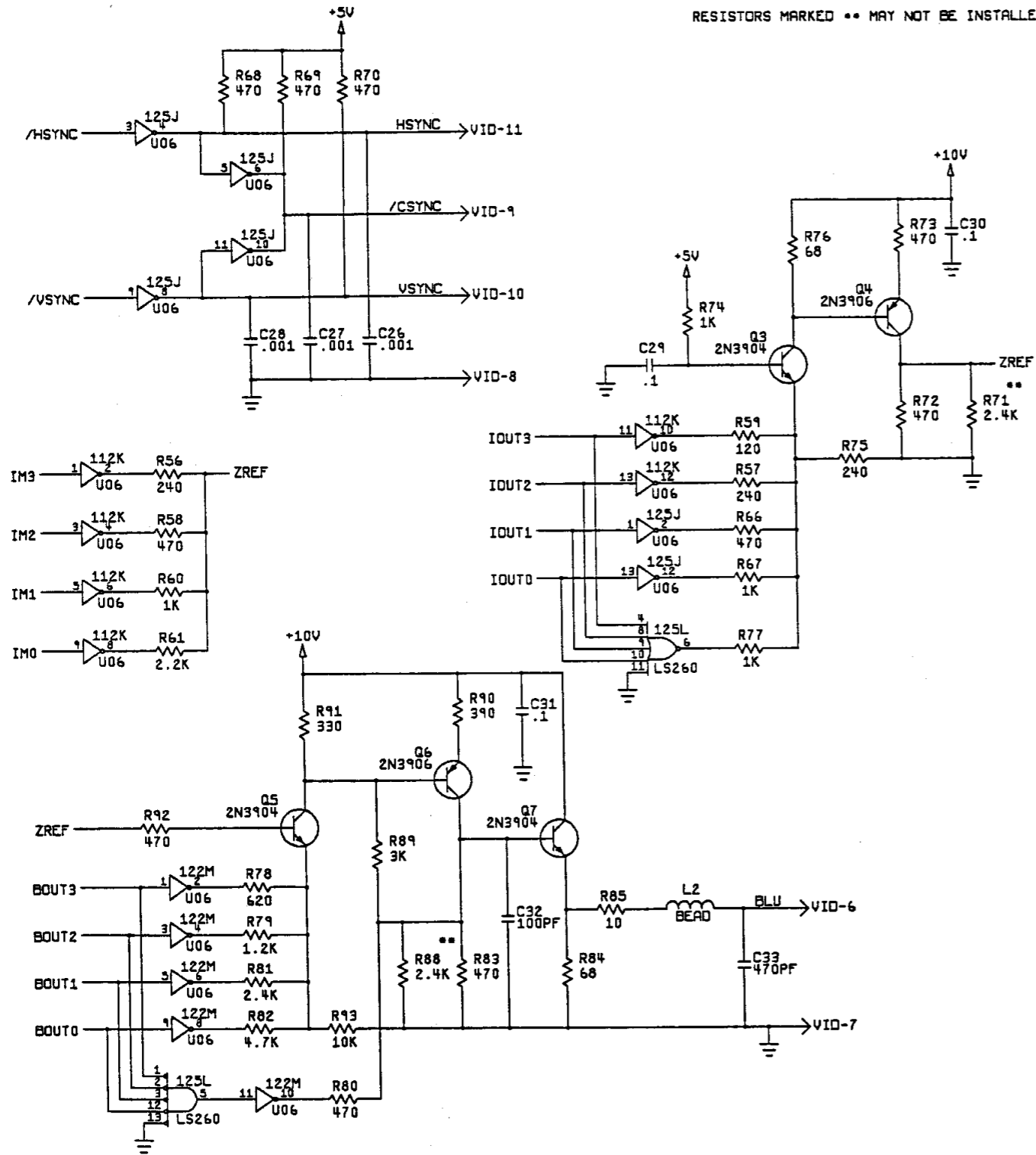

RGB

NOTICE TO ALL PERSONS RECEIVING THIS DRAWING
 CONFIDENTIAL: Reproduction forbidden without the specific written permission of Atari Games Corporation, Milpitas, CA. This drawing is only conditionally issued and neither receipt nor possession thereof confers or transfers any right in, or license to use, the subject matter of the drawing or any design or technical information shown thereon, nor any right to reproduce this drawing, or any part thereof. Except for manufacture by vendors of Atari Games Corporation, and for manufacture under the corporation's written license, no right is granted to reproduce this drawing or the subject matter thereof, unless by written agreement with or written permission from the corporation.

Escape From the Planet of the Robot Monsters
Main PCB Assembly
Schematic Diagram

© 1989 Atari Games Corporation
 A06145-01 D

SP-332 Sheet 10
 1st printing

ACDC-11 >-- KEY

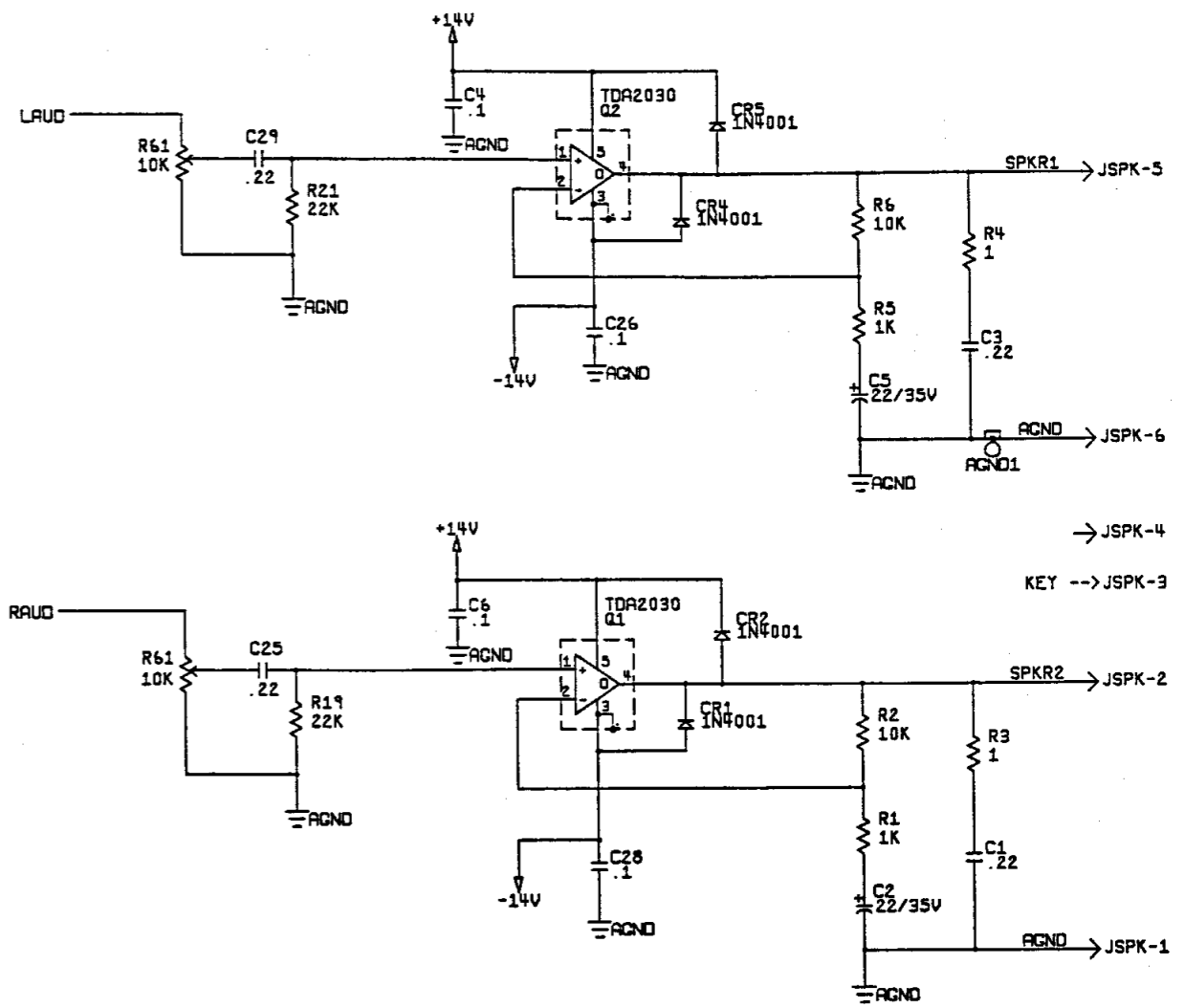
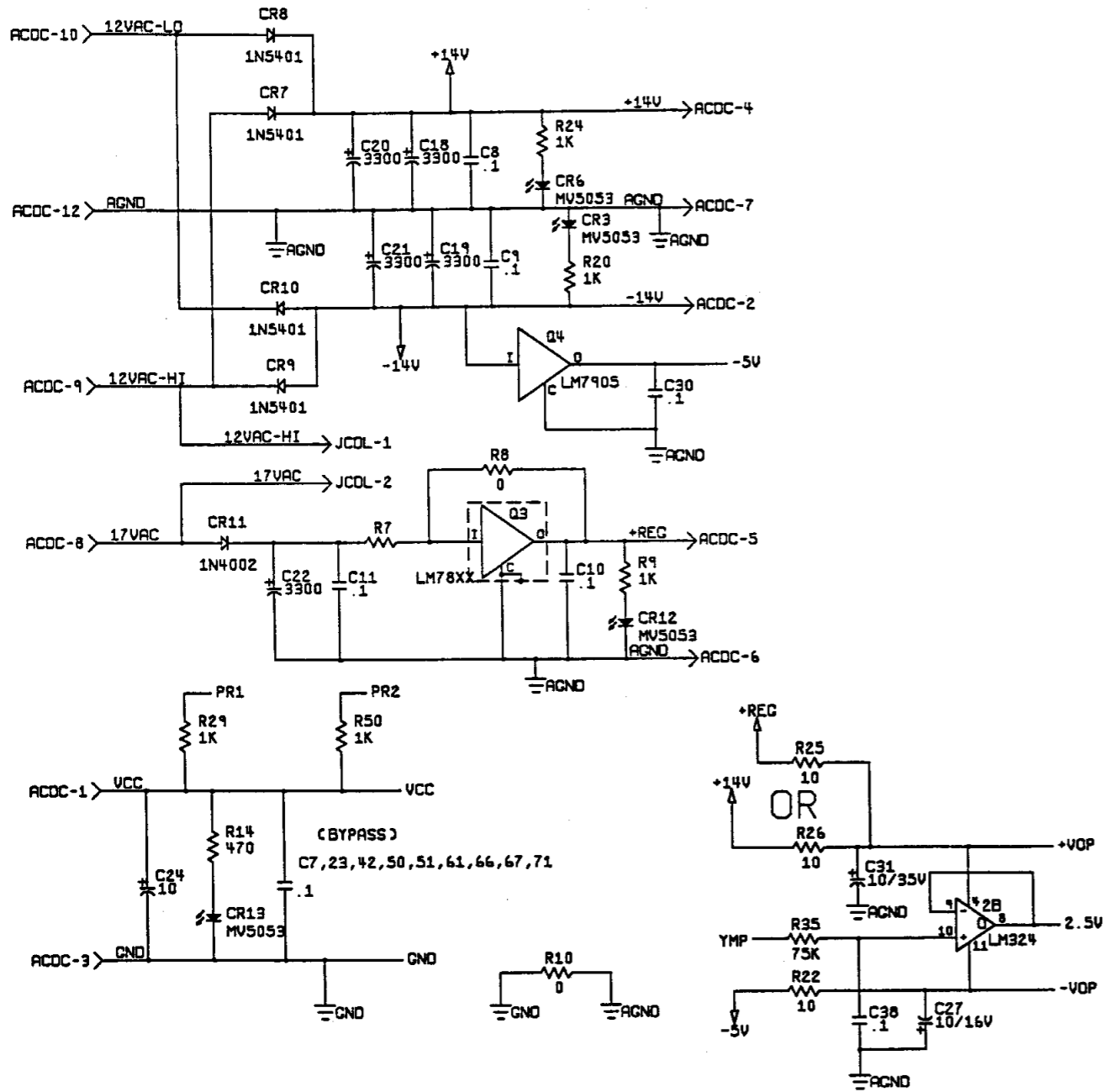

NOTICE TO ALL PERSONS RECEIVING THIS DRAWING
 CONFIDENTIAL: Reproduction forbidden without the specific written permission of Atari Games Corporation, Milpitas, CA. This drawing is only conditionally issued and neither receipt nor possession thereof confers or transfers any right in, or license to use, the subject matter of the drawing or any design or technical information shown thereon, nor any right to reproduce this drawing, or any part thereof. Except for manufacture by vendors of Atari Games Corporation, and for manufacture under the corporation's written license, no right is granted to reproduce this drawing or the subject matter thereof, unless by written agreement with or written permission from the corporation.

Escape From the Planet of the Robot Monsters Stand-Alone Audio PCB Assembly Schematic Diagram

© 1989 Atari Games Corporation
 A043713-XX D

SP-332 Sheet 11
 1st printing

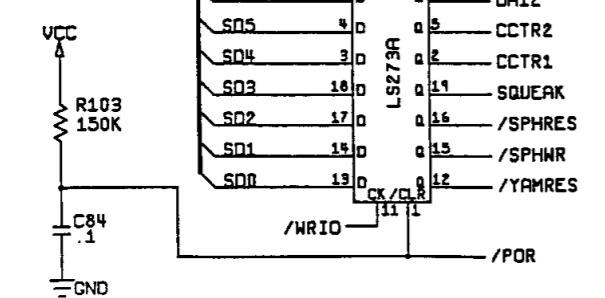
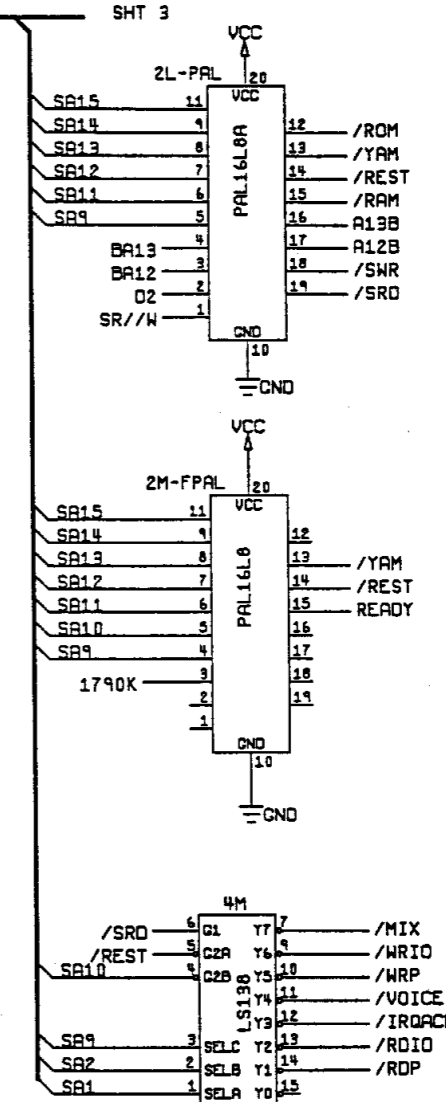
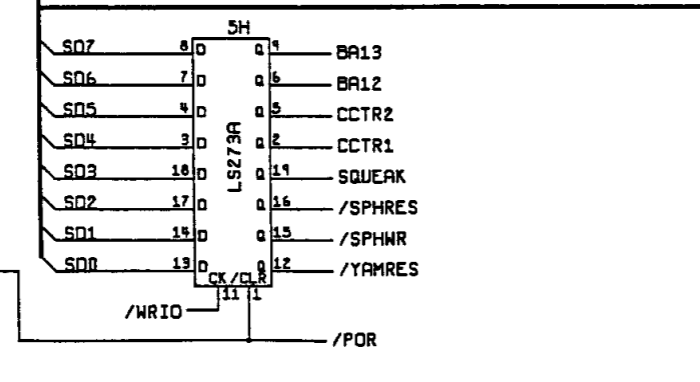
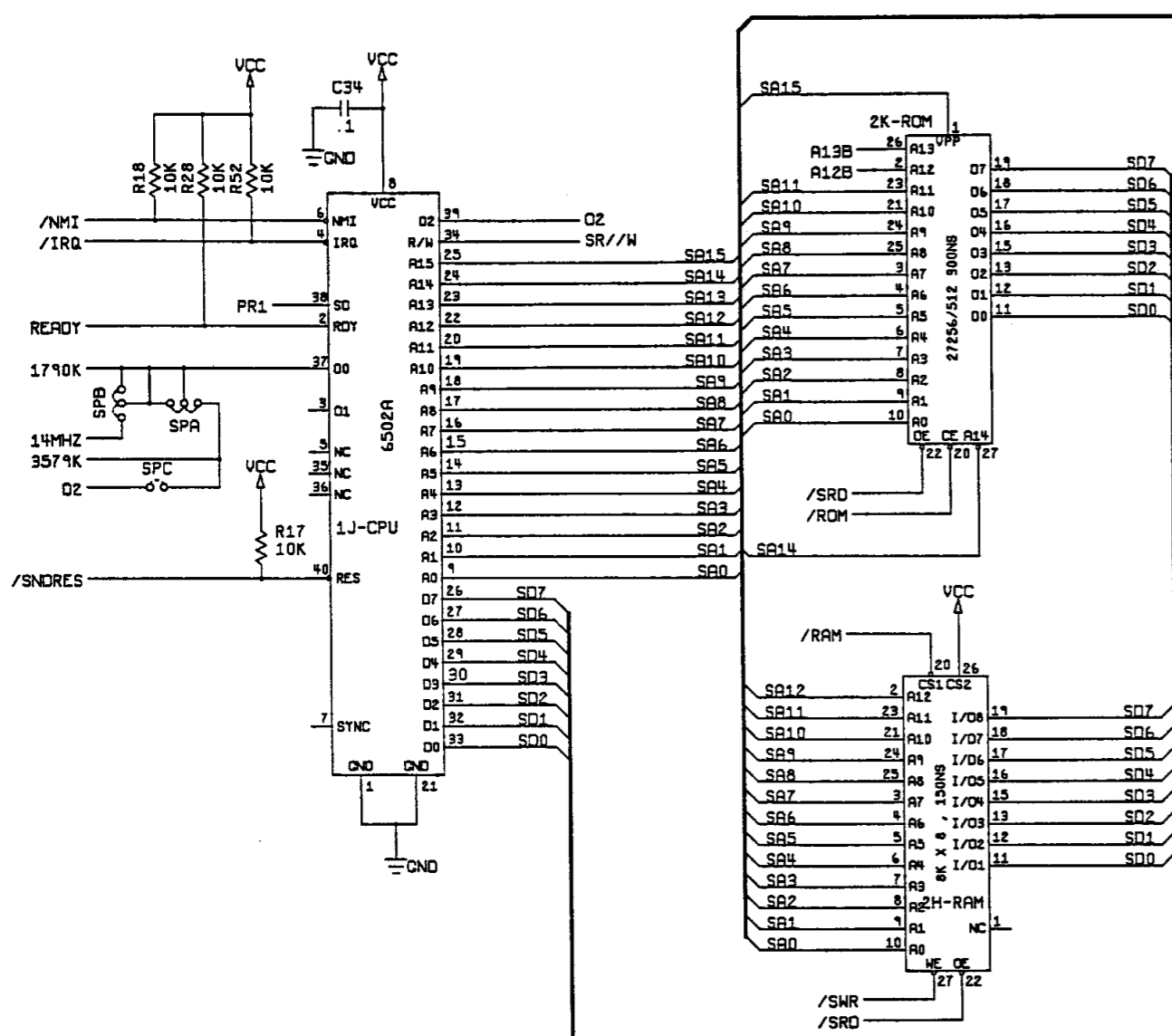

NOTICE TO ALL PERSONS RECEIVING THIS DRAWING
 CONFIDENTIAL: Reproduction forbidden without the specific written permission of Atari Games Corporation, Milpitas, CA. This drawing is only conditionally issued and neither receipt nor possession thereof confers or transfers any right in, or license to use, the subject matter of the drawing or any design or technical information shown thereon, nor any right to reproduce this drawing, or any part thereof. Except for manufacture by vendors of Atari Games Corporation, and for manufacture under the corporation's written license, no right is granted to reproduce this drawing or the subject matter thereof, unless by written agreement with or written permission from the corporation.

Escape From the Planet of the Robot Monsters Stand-Alone Audio PCB Assembly Schematic Diagram

© 1989 Atari Games Corporation
 A043713-XX D

SP-332 Sheet 12
 1st printing

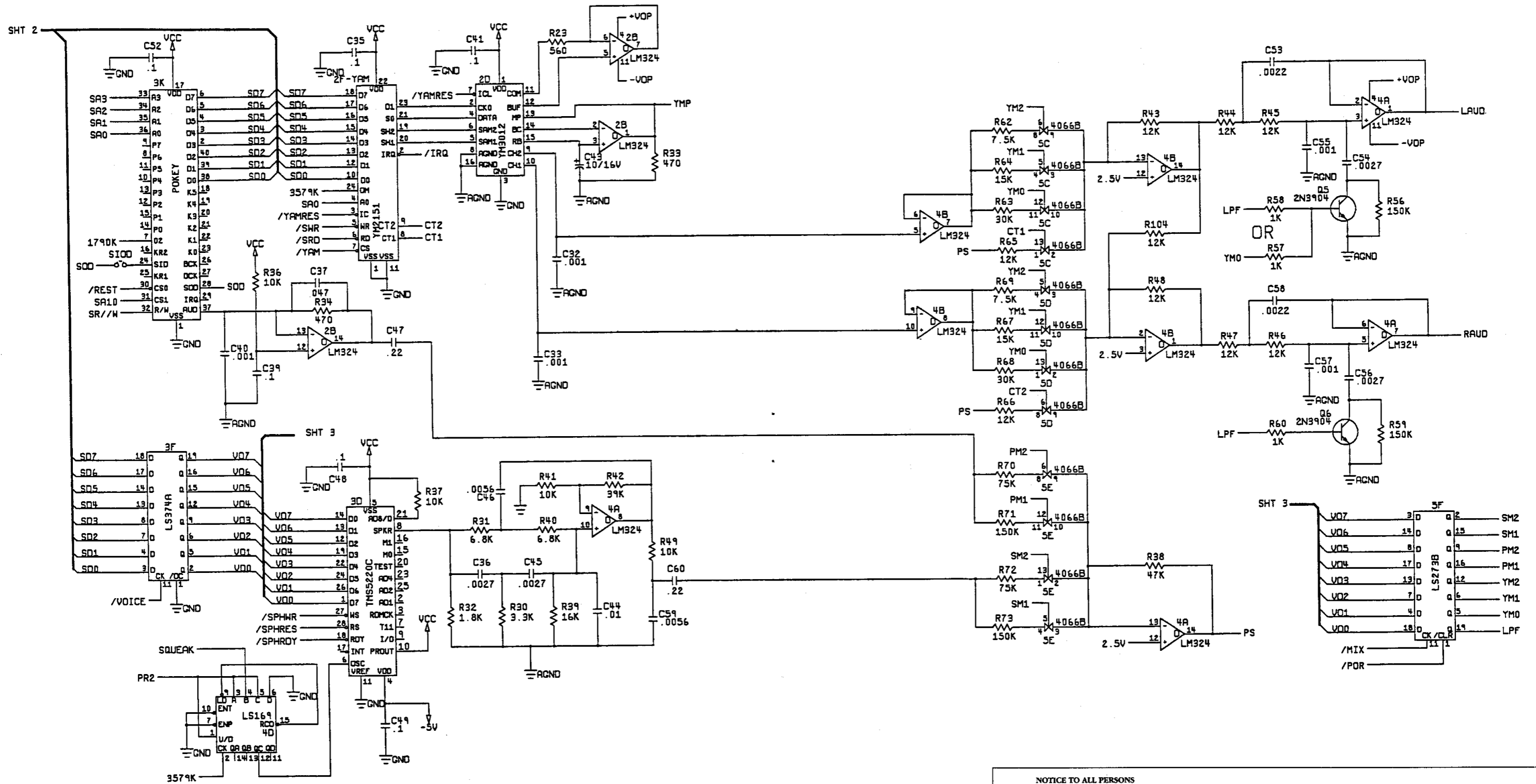

NOTICE TO ALL PERSONS RECEIVING THIS DRAWING
 CONFIDENTIAL: Reproduction forbidden without the specific written permission of Atari Games Corporation, Milpitas, CA. This drawing is only conditionally issued and neither receipt nor possession thereof confers or transfers any right in, or license to use, the subject matter of the drawing or any design or technical information shown thereon, nor any right to reproduce this drawing, or any part thereof. Except for manufacture by vendors of Atari Games Corporation, and for manufacture under the corporation's written license, no right is granted to reproduce this drawing or the subject matter thereof, unless by written agreement with or written permission from the corporation.

**Escape From the Planet of the Robot Monsters
 Stand-Alone Audio PCB Assembly
 Schematic Diagram**

© 1989 Atari Games Corporation
 A045713-XX D

**SP-332 Sheet 13
 1st printing**

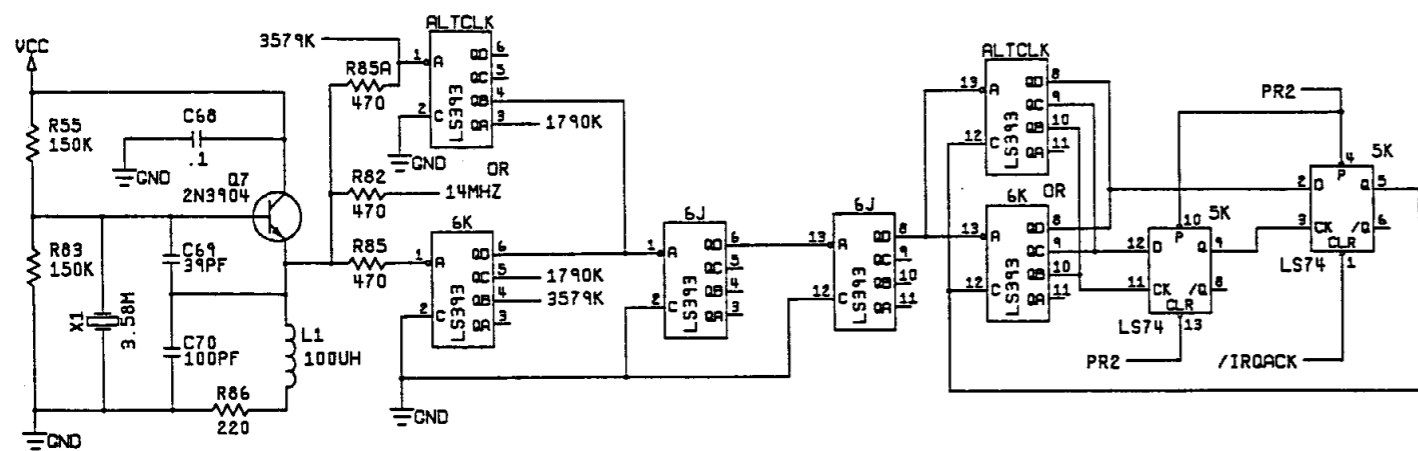

KEY --> JSCOM-5

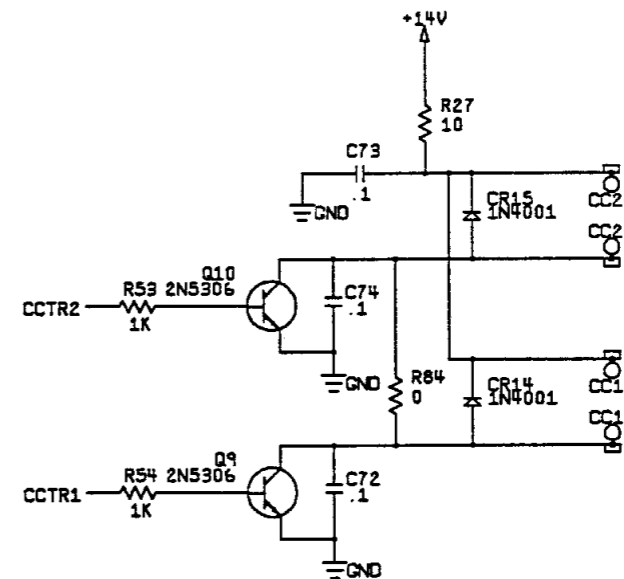
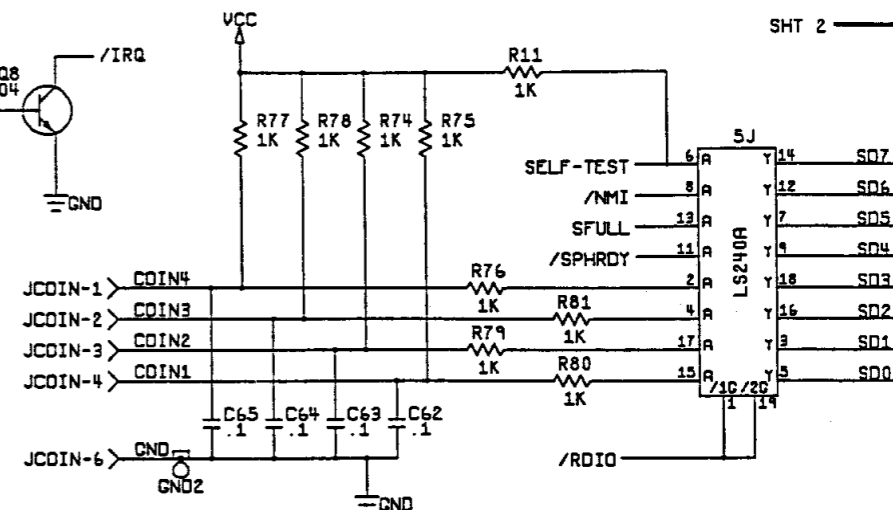
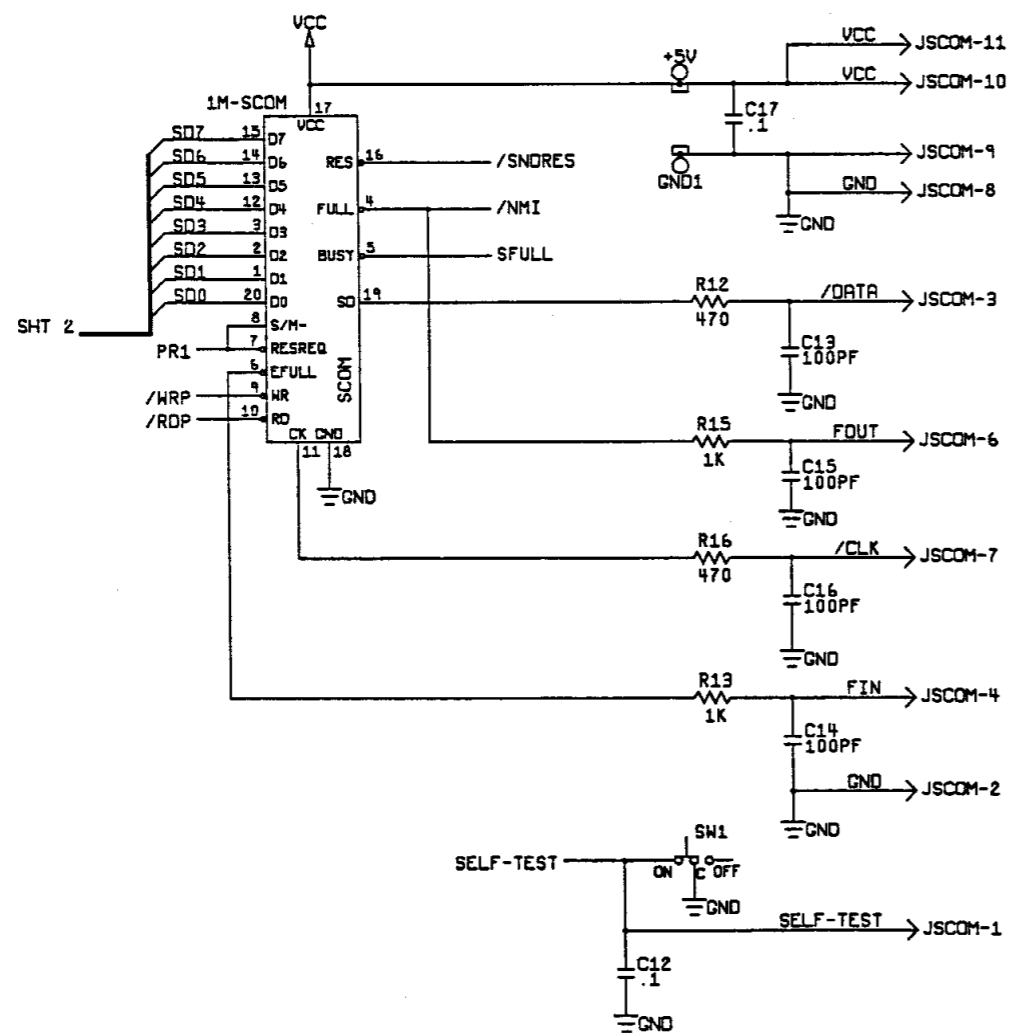

NOTICE TO ALL PERSONS RECEIVING THIS DRAWING
 CONFIDENTIAL: Reproduction forbidden without the specific written permission of Atari Games Corporation, Milpitas, CA. This drawing is only conditionally issued and neither receipt nor possession thereof confers or transfers any right in, or license to use, the subject matter of the drawing or any design or technical information shown thereon, nor any right to reproduce this drawing, or any part thereof. Except for manufacture by vendors of Atari Games Corporation, and for manufacture under the corporation's written license, no right is granted to reproduce this drawing or the subject matter thereof, unless by written agreement with or written permission from the corporation.

Escape From the Planet of the Robot Monsters Stand-Alone Audio PCB Assembly Schematic Diagram

© 1989 Atari Games Corporation
 A043713-XX D

SP-332 Sheet 14
 1st printing

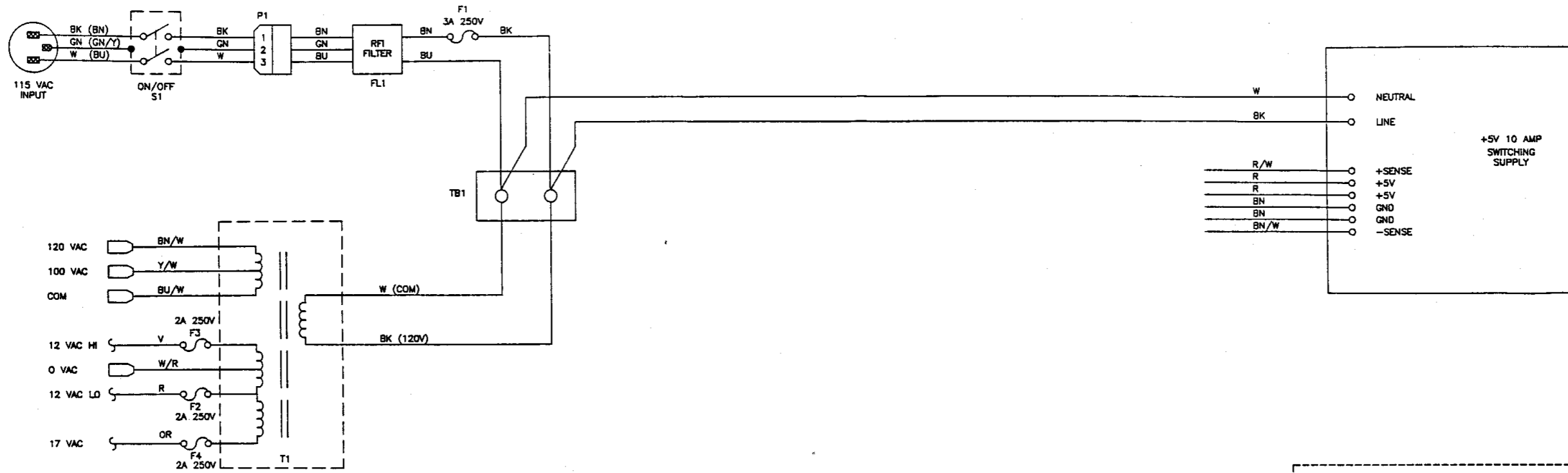

Switching/Linear Power Supply

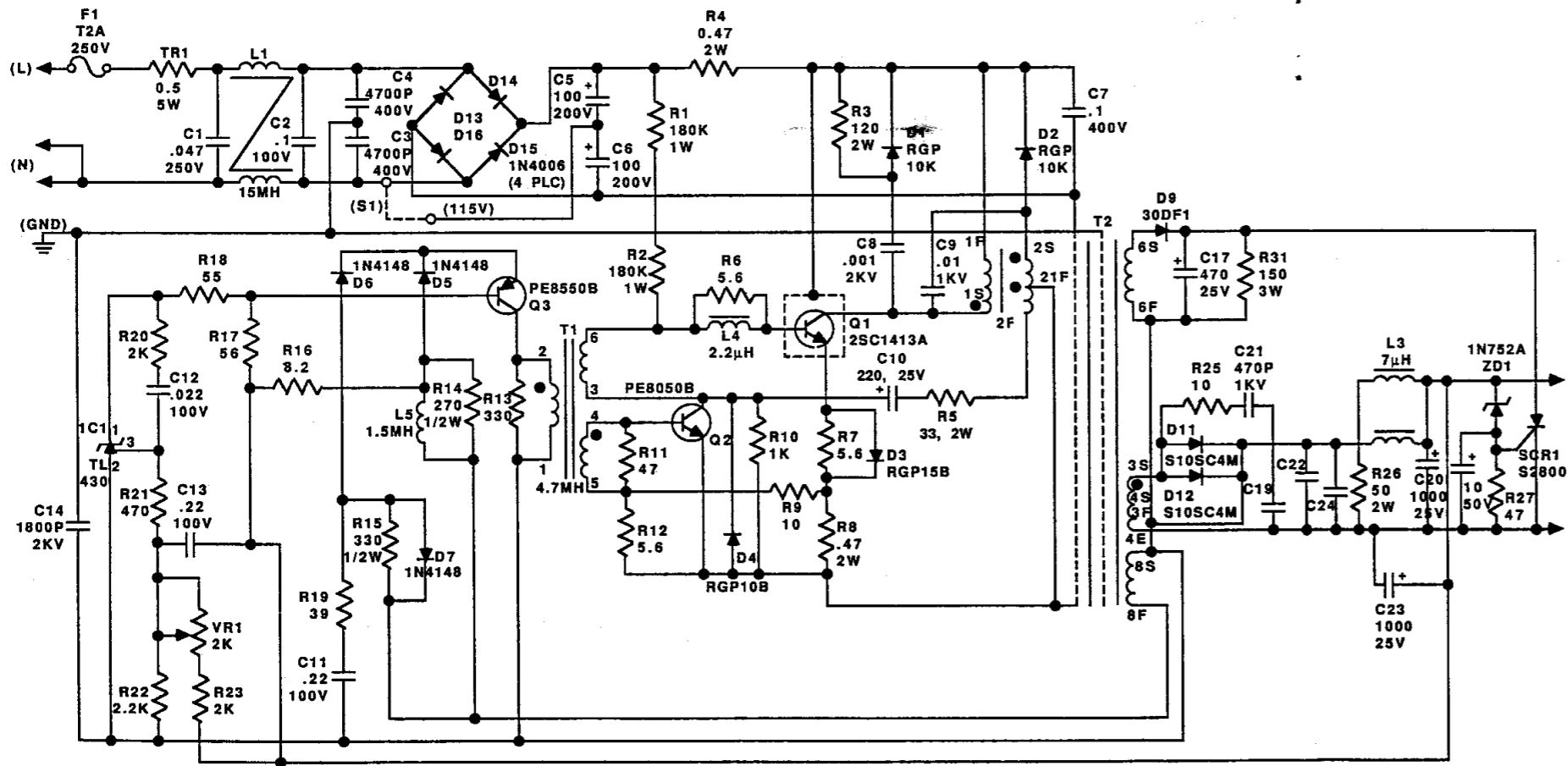

Hitron 5V 10A Switching Power Supply

ATARI PART NO: 149003-003 (120V)
149003-103 (240V)

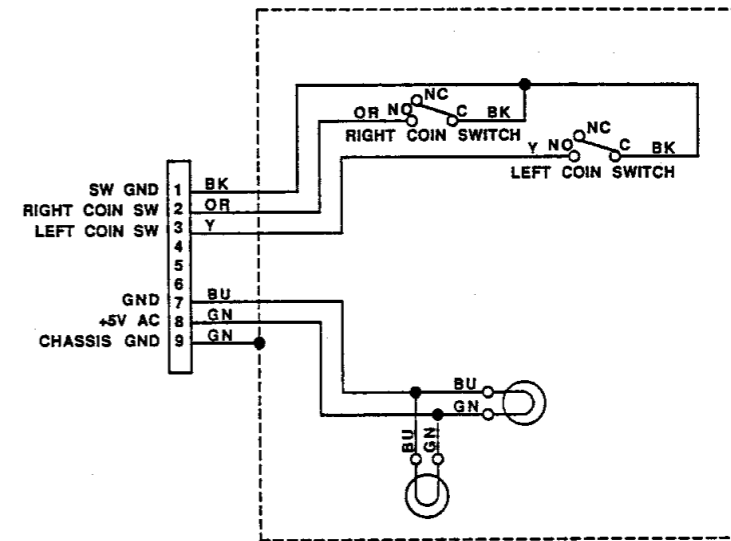

Coin Door Wiring Diagram

NOTICE TO ALL PERSONS RECEIVING THIS DRAWING

CONFIDENTIAL: Reproduction forbidden without the specific written permission of Atari Games Corporation, Milpitas, CA. This drawing is only conditionally issued and neither receipt nor possession thereof confers or transfers any right in, or license to use, the subject matter of the drawing or any design or technical information shown thereon, nor any right to reproduce this drawing, or any part thereof. Except for manufacture by vendors of Atari Games Corporation, and for manufacture under the corporation's written license, no right is granted to reproduce this drawing or the subject matter thereof, unless by written agreement with or written permission from the corporation.

Switching/Linear Power Supply, Hitron 5V, 10A Switching Power Supply, and Coin Door Wiring Diagrams

Escape Main PCB Memory Map

Video CPU Memory Map

All addresses can be accessed in byte or word mode.

Type	Address	R/W	Data
Program ROM	000000-05FFFF	R	D15-D0
Program ROM	060000-07FFFF	R	(See common memory map below)
Program ROM	080000-09FFFF	R	D15-D0
EEPROM	0E0001-0E2FFF	R/W	D7-D0
UNLOCK EEPROM	160000-17FFFF	W	(See common memory map below)
Watch Dog	1Fxxxx	W	(See common memory map below)
	260000-260030	W	xx (128 msec. timeout)
	2E0000	W	(See common memory map below)
	360000-360030	W	(See common memory map below)
Color RAM Alpha	3E0000-3E01FF	R/W	D15-D0
Color RAM spare	3E0080-3E00FF		
Color RAM spare	3E0180-3E01FF		
Color RAM Motion Object	3E0200-3E03FF	R/W	D15-D0
Color RAM Playfield	3E0400-3E05FF	R/W	D15-D0
Color RAM Playfield Shadow	3E0600-3E07FF	R/W	D15-D0
Color RAM STAIN	3E0800-3E0FFF	R/W	D15-D0
Playfield picture RAM	3F0000-3F1FFF	R/W	D15-D0
Motion Object RAM	3F2000-3F3FFF	R/W	D15-D0
(Link, Picture, H-Pos, V-Pos, Link, etc.)			
AlphaNumerics RAM	3F4000-3F4EFF	R/W	D15-D0
Scroll and MOB config	3F4F00-3F4F7F	R/W	D15-D0
SLIP pointers	3F4F80-3F4FFF	R/W	D9-D0 M.O. link pointers
Working RAM	3F5000-3F7FFF	R/W	D15-D0
Playfield palette RAM	3F8000-3F9FFF	R/W	D11-D8

Extra CPU Memory Map

Type	Address	R/W	Data
Program ROM	000000-05FFFF	R	D15-D0
	060000-360030		(See common memory map below)

Common Memory Map

Both processors use the same addresses to access this information.

Type	Address	R/W	Data
Program ROM	060000-07FFFF	R	D15-D0
Program RAM	160000-16FFFF	R/W	D15-D0
<i>I/O</i>			
<i>All the I/O is decoded in word mode only.</i>			
Player 1 Input	260000	R	D8-D11
Player 2 Input	260010	R	D8-D11
			D11 duck
			D10 spare
			D9 fire
			D8 start
VBLANK	260010	R	D0 Active lo
Self-test	260010	R	D1 Active lo
Input-buffer Full (@ 260030)	260010	R	D2 Active lo
Output-Buffer Full (@ 260030)	260010	R	D3 Active lo
ADEOC, end of conversion	260010	R	D4 ACTICE hi
ADC 0 ANALOG PORT	260020	R	D0-D7
ADC 1	260022	R	D0-D7
ADC 2	260024	R	D0-D7
ADC 3	260026	R	D0-D7
Read Sound Processor (SCOM)	260030	R	D0-D7
Vblank interrupt ack.	360000	W	xx
LATCH	Video Off	360010	W D5 0=on
	Video intensity	360010	W D4-D1 0=full on
	EXTRA cpu reset	360010	W D0 Lo to reset
Sound Processor Reset	360020	W	xx
Write Sound Processor (SCOM)	360030	W	D0-D7

ROM Errors and Locations

Address	ROM Location		Used By
	High	Low	
000000	10U	10S	Second processor only
000000	50A	40A	Video processor only
020000	50B	40B	Video processor only
040000	50D	40D	Video processor only
060000	40K	50K	Common ROM (video and second processor)
090000	50E	40E	Video processor only

RAM Errors and Locations

Address	RAM Location		Used By
	High	Low	
160000	40M	50M	Common RAM (Video and second processor)
3E0000	112H	112F	Video processor only
3F0000	70D	86D	Video processor only
3F4000	70F	86F	Video processor only
3F8000	70H	n/a	Video processor only

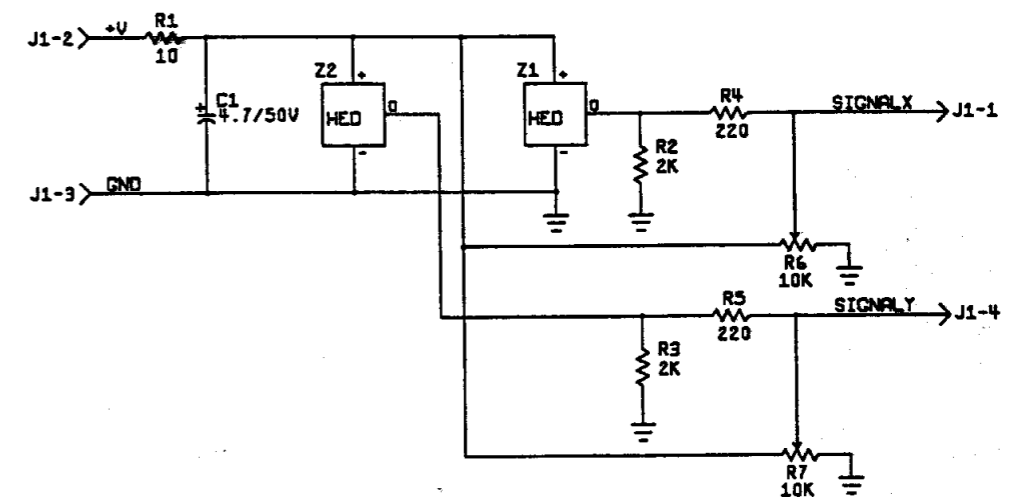

NOTICE TO ALL PERSONS RECEIVING THIS DRAWING

CONFIDENTIAL: Reproduction forbidden without the specific written permission of Atari Games Corporation, Milpitas, CA. This drawing is only conditionally issued and neither receipt nor possession thereof confers or transfers any right in, or license to use, the subject matter of the drawing or any design or technical information shown thereon, nor any right to reproduce this drawing, or any part thereof. Except for manufacture by vendors of Atari Games Corporation, and for manufacture under the corporation's written license, no right is granted to reproduce this drawing or the subject matter thereof, unless by written agreement with or written permission from the corporation.

Escape From the Planet of the Robot Monsters Memory Map, Faulty RAM/ROM Tables, and Hall Effect Joystick Schematic